

МІНІСТЕРСТВО ОСВІТИ І НАУКИ УКРАЇНИ
НАЦІОНАЛЬНИЙ АВІАЦІЙНИЙ УНІВЕРСИТЕТ

Кафедра авіаційних комп'ютерно-інтегрованих комплексів

ДОПУСТИТИ ДО ЗАХИСТУ

Завідувач кафедри

Синеглазов В.М.

“ _____ ” _____ 2021.

ДИПЛОМНА РОБОТА

(ПОЯСНЮВАЛЬНА ЗАПИСКА)

ВИПУСНИКА ОСВІТНЬО-КВАЛІФІКАЦІЙНОГО РІВНЯ

“БАКАЛАВР”

Тема: Автоматична система керування безпілотним літальним апаратом

Виконав:

Максимчук М. В.

Керівник: к.т.н.

Тупіцин М. Ф.

Нормоконтролер: к.т.н.

Тупіцин М. Ф.

Київ – 2021

EDUCATION AND SCIENCE MINISTRY OF UKRAINE

NATIONAL AVIATION UNIVERSITY

COMPUTER-INTEGRATED COMPLEXES DEPARTMENT

ADMIT TO DEFENSE

Head of department

Sineglazov V. M.

“ _____ ” _____ 2021.

BACHELOR WORK

(EXPLANATORY NOTES)

Topic: Automated control system for unmanned aerial vehicle

Done by:

Maksymchuk M. V.

Supervised by:

Tupitsyn M. F.

Normcontrolled by:

Tupitsyn M. F.

Kyiv 2021

НАЦІОНАЛЬНИЙ АВІАЦІЙНИЙ УНІВЕРСИТЕТ
Факультет аеронавігації, електроніки та телекомунікацій
Кафедра авіаційних комп'ютерно-інтегрованих комплексів

Освітній ступінь бакалавр

Спеціальність: 151 «Автоматизація та комп'ютерно-інтегровані технології»

ЗАТВЕРДЖУЮ

Завідувач кафедри

Синеглазов В.М.

“ _____ ” _____ 2021 р.

ЗАВДАННЯ

на виконання дипломної роботи студента

Максимчук Михайло Вікторович

- 1. Тема проекту (роботи):** «Система автоматичного управління безпілотного літального апарата»
- 2. Термін виконання проекту (роботи):** з 19.04.2021 р. до 09.06.2021 р.
- 3. Вихідні дані до проекту (роботи):** Технічні характеристики систем автоматичного управління (САУ) безпілотного літального апарата (БЛА). Льотно-технічні параметри безпілотного літального апарата.
- 4. Передумови проекту (роботи):** Зосередити увагу на алгоритмах дії систем автоматичного управління БЛА.
- 5. Зміст пояснювальної записки (перелік питань, що підлягають розробці):**
 1. Аналіз технічних характеристик САУ та льотно-технічних параметрів БЛА. Актуальність роботи.
 2. Постановка завдання.
 3. Комплекс технічних засобів для виконання завдання. Алгоритм роботи пропонованої САУ підвищеної надійності.
 4. Розробка програмного забезпечення.
 5. Розрахунки функціонування системи автоматичного управління БЛА по заданому критерію.
 6. Структура розробленої САУ з елементами, що дублюються
- 6. Перелік обов'язкового графічного матеріалу:**
 1. Структурні розробленої системи;
 2. Алгоритм роботи пропонованої системи;
 3. Результаті розрахунків.

7. Календарний план-графік

№	Етапи виконання бакалаврської роботи	Строк виконання	Примітка про виконання
1	Ознайомлення із завданням бакалаврської роботи	14.04.21-16.04.21	
2	Огляд та аналіз систем автоматичного управління системами та алгоритмами	16.04.21-24.04.21	
3	Вибір математичної моделі рішення задачі	25.04.21-08.05.21	
4	Опис алгоритму вирішення завдання	09.05.21-24.05.21	
5	Розрахунок параметрів системи автоматичного управління. Аналіз результатів	25.05.21-30.05.21	
6	Розроблення бакалаврських робіт	31.05.21–09.06.21	

8. Дата видачі завдання: "19" квітня 2021 р.

Керівник: к.т.н., доцент _____ Тупіцин М.Ф.
(підпис)

Завдання прийняв до виконання _____ Максимчук М.В.
(підпис)

NATIONAL AVIATION UNIVERSITY

Faculty of aeronavigation, electronics and telecommunications

Department of Aviation Computer Integrated Complexes

Educational level bachelor

Specialty: 151 "Automation and computer-integrated technologies"

APPROVED

Head of Department

Sineglazov V. M.

" ____ " _____ 2021

TASK

For the student's thesis

Maksymchuk Mykhailo Viktorovych

- 1. Theme of the project:** «Automated control system for unmanned aerial vehicle»
- 2. The term of the project (work):** from April 19, 2021 until June 09, 2021
- 3. Output data to the project (work):** Technical characteristics of automatic control systems (ACS) of unmanned aerial vehicles (UAVs). Flight technical parameters of unmanned aircraft
- 4. Project prerequisites (works):** Focus on the algorithms of automatic UAV control systems
- 5. Contents of the explanatory note (list of questions to be developed):**
 1. Analysis of technical characteristics of ACS and flight-technical parameters of UAVs. Relevance of work.
 2. Statement of the task.
 3. A set of technical means to perform the task. Algorithm of operation of the offered ACS of the increased reliability.
 4. Software development.
 5. Calculations of the automatic control system of the UAV according to the specified criteria.
 6. The structure of the developed ACS with duplicate elements
- 6. List of compulsory graphic material:**
 1. The structure of the developed system;
 2. The algorithm of the proposed system;
 3. The results of calculations.

7. Planned schedule:

№	Stages of execution of bachelor work	Term of execution	Note of execution
1	Acquaintance with the task of the bachelor work	14.04.21-16.04.21	
2	Review and analysis of systems and algorithms automatic control system	16.04.21-24.04.21	
3	Choose of the mathematical model of task solution	25.04.21-08.05.21	
4	Description of the algorithm of task solution	09.05.21-24.05.21	
5	Parameters calculation of the automatic control system. Analysis of the results	25.05.21-30.05.21	
6	Designing of bachelor work	31.05.21–09.06.21	

8. Date of task receiving: “19” April 2021

Diploma thesis supervisor

Tupitsyn M.F.

(signature)

Issued task accepted

Maksymchuk M.V.

(signature)

РЕФЕРАТ

Пояснювальна записка до дипломної роботи "Автоматична система керування безпілотним літальним апаратом": с., рис., табл., 20 літературних джерел.

Об'єкт дослідження: процес керування рухом безпілотного літального апарату.

Предмет дослідження: система керування позовжнім рухом безпілотного літального апарату.

Методи дослідження: при вирішенні поставлених задач використовувався метод Циглер-Ніколса, Для математичних розрахунків та моделювання застосовувався пакет прикладних програм MATLAB.

Мета роботи: забезпечення ефективного керування безпілотним літальним апаратом у просторі, що дозволить покращити керованість та стабільність літального апарату в режимі автоматичного польоту.

Для досягнення цієї мети необхідно розв'язати наступні завдання:

- огляд предметної області та аналіз існуючих систем керування;
- розробити структурну схему системи керування БПЛА;
- розробити математичну модель системи керування БПЛА;
- провести моделювання системи керування БПЛА на базі математичної моделі в графічному середовищі MATLAB/Simulink;
- виконати синтез системи керування кутом тангажа БПЛА з допомогою ПІД-регулятора.

Матеріали дипломного проекту можуть бути використані для удосконалення або подальшого розвитку систем керування безпілотних літальних апаратів.

БЕЗПІЛОТНИЙ ЛІТАЛЬНИЙ АПАРАТ, АВТОМАТИЧНА СИСТЕМА КЕРУВАННЯ, ПІД-РЕГУЛЯТОР, МЕТОД ЗІГЛЕРА-НІКОЛСА.

ABSTRACT

Explanatory note to the thesis "Automated control system for unmanned aerial vehicles": p., fig., table, 20 references.

The object of research: the process of controlling the movement of an unmanned aerial vehicle.

Subject of research: longitudinal motion control system for unmanned aerial vehicles.

Methods of research: the Ziegler-Nichols method was used in solving the set tasks. The MATLAB application package was used for mathematical calculations, the system modeling was performed in the MATLAB/Simulink graphical environment.

The purpose of the work: ensuring effective control of the unmanned aerial vehicle in space, which will improve the controllability and stability of the aircraft in automatic flight mode.

To achieve this purpose, it must be solved the following tasks:

- subject area review and analysis of existing management systems;
- develop a block diagram of the UAV control system;
- to develop a mathematical model of the UAV control system;
- to model the UAV control system on the basis of a mathematical model in the graphical environment MATLAB / Simulink;
- perform the synthesis of the control system of the UAV pitch angle using the PID-regulator.

Diploma project materials can be used to improve or further develop control systems for unmanned aerial vehicles

UNMANNED AIRCRAFT VEHICLE, AUTOMATIC CONTROL SYSTEM, PID-REGULATOR, ZIGLER-NICOLS METHOD.

CONTENT

Glossary.....	
Introduction.....	
1. Review of literature and research of the aircraft control process, analysis of existing control system.....	
1.1 Analysis of the characteristics of unmanned aerial vehicles and their application.....	
1.2 Description of control systems.....	
1.3 Analysis of elements of aircraft control systems.....	
1.4 Analysis of guidance system for unmanned aerial vehicles.....	
1.4.1 Telecontrol systems.....	
1.4.2 Autonomous systems.....	
1.4.3 Combined control systems and their areas of application.....	
1.5. Defining the requirements for the automatic control system.....	
2. Development of a mathematical model of an unmanned aircraft vehicle movement.....	
2.1 Mathematical model of unmanned aircraft vehicle movement.....	
2.2 Linearization of the unmanned aircraft vehicle longitudinal model.....	
2.2.1 Disturbed and undisturbed movement.....	
2.2.2 Linearization of the obtained system of equations of unmanned aircraft vehicle longitudinal motion.....	
2.3 Control object balancing.....	
2.4 Calculation of dynamic coefficients and corresponding transfer functions.....	
3. Synthesis of the control system for the longitudinal motion of the unmanned aircraft vehicle.....	
3.1 Development of structural diagram of unmanned aircraft vehicle control system.....	
3.2 Control laws synthesis for unmanned aircraft vehicle control system.....	



3.2.1 Preliminaries of flight control of control object.....

3.2.2. Overall design of the flight trajectory control system.....

3.2.3. Stabilization control.....

3.2.4 Attitude control.....

3.2.5 Navigation control.....

3.3 Selection of the controller for the UAV control system and its theoretical description.....

4. Research of the control system for the longitudinal motion of the unmanned aircraft vehicle.....

4.1 Investigation of unmanned aircraft vehicle transfer function in MATLAB environment.....

4.2 Investigation of unmanned aircraft vehicle control system in MATLAB and MATLAB/Simulink environment.....

Conclusions

References.....

Appendix.....

Appendix A.....



GLOSSARY

UAV – Unmanned Aerial Vehicle

CO – Control Object

ACS – Automated Control System

CS – Control System



INTRODUCTION

Recently, the development of mobile robots has acquired rapid pace, especially the use of unmanned aerial vehicles (UAVs) in various fields of human activity has become especially popular. This is primarily due to the advantages of the drone. Due to the small size, reliable design, compactness, maneuverability, ease of operation, having low weight with a significant payload, unmanned aerial vehicles are able to perform a wide range of tasks.

They are successfully used for aerial photography and mapping, operational forecasting and assessment of the consequences of emergencies, monitoring of industrial facilities and natural complexes, delivery of goods, for entertainment purposes and more.

Today, most existing unmanned aerial vehicles are manually piloted using radio-controlled remote controls. At manual control of the UAV there are difficulties connected with preparation of operators, insufficient working range, and also the restrictions connected with weather conditions.

However, there are many factors and problems associated with piloting an unmanned aerial vehicle. For example, the stability of the UAV flight in the vertical channel depends on the regulators installed in the control system. The need for flight control in this channel is observed from the principles of the whole system.

That is why the actual topic for the thesis is the development of the UAV control system, namely in the longitudinal control channel.

The flight control system of an unmanned aerial vehicle is one of its most important components, which largely determines the method and effectiveness of the aircraft. Their purpose is to ensure a constant value of the controlled quantity or its change according to a given control law. The accuracy of the stabilization system is estimated by the magnitude of the error in adjusting the original coordinate. The current level of requirements for unmanned aerial vehicles requires rapid improvement and



development of control systems, increasing their reliability and the need to develop new methods of maintenance in preparation for use.

In general, the control of the aircraft's flight is understood as the maintenance of a given trajectory of its center of mass, as well as stabilization and orientation relative to it. The solution to this problem is to develop an automatic or semi-automatic control system.

Automatic control of the aircraft can be called the process of changes and stabilization of individual parameters of the aircraft and purposeful control of the flight path of the aircraft. The tasks of automatic flight control are interrelated with the problem of solving the problems of UAV development. The developed automated control system must respond to changes in the parameters of the control object and the elements of the regulator, the characteristics of the control effects.

The flight control system solves the problem of stabilization, ie processes guidance commands and ensures stability. That is why the aim of the diploma project was to develop an appropriate regulator to improve flight stabilization, which is a relevance, promising and important scientific task.



CHAPTER 1. REVIEW OF LITERATURE AND RESEARCH OF THE AIRCRAFT CONTROL PROCESS, ANALYSIS OF EXISTING CONTROL SYSTEMS

1.1 Analysis of the characteristics of unmanned aerial vehicles and their application

According to the definition approved by the ICAO Assembly [1], "An UAV (drone) is an unmanned aircraft that flies without an aircraft commander on board and is either fully remotely controlled from another location on the ground, from another aircraft, from space, or programmed and fully autonomous."

Aviation experts distinguish two main types of aircraft, in addition to military missiles, which fly without airborne pilots:

- Remote controlled;
- Programmed and operated by navigation systems;

For the first time, civilian use of drones was announced by Amazon [2] for the delivery of consumer goods in 2013. After that, the market began to develop rapidly, opening up new areas of commercial and private use. In addition to the manufacturers of UAVs themselves, distributors of such devices, manufacturers of components, optics and computer vision systems, software, companies of mapping services and aerial photography, the agricultural sector, a wide range of government services (police, ambulance, firefighters, emergency services), insurance and investment companies and others. Also, now with the help of drones, the assessment of air pollution and radioactivity is being carried out, objects are being protected, there is also an idea of using drones to deliver medicines and medical devices to the scene of an incident, extinguishers

<i>ACIC DEPARTMENT</i>				<i>NAU 21 0618 000 EN</i>			
<i>Performed</i>	<i>Maksymchuk M. V.</i>			<i>AUTOMATED CONTROL SYSTEM FOR UNMANNED AERIAL VEHICLES</i>	<i>N.</i>	<i>Page</i>	<i>Pages</i>
<i>Supervisor</i>	<i>Tupitsyn M.F.</i>						
<i>Consultant</i>							
<i>S. controller</i>	<i>Tupitsyn M.F.</i>						
<i>Dep. head</i>	<i>Sineglazov V. M.</i>						
					<i>431 151</i>		

for extinguishing, and even the delivery of ammunition.

UAVs are difficult to classify as they have very different characteristics. This diversity comes from the abundance of UAV configurations and components. Manufacturers are not yet limited by any standards. As a result, today there are no requirements from aviation regulators on how the UAV should be equipped.

UAVs [3,4] differ in size, flight range, flight speed, functionality, level of autonomy, flight duration and other characteristics.

Conventionally, all drones can be divided into 4 groups:

- Micro. Such UAVs weigh less than 10 kg, the maximum time spent in the air is 60 minutes. Flight altitude - 1 kilometer.

- Mini. The weight of these devices reaches 50 kg, the residence time in the air reaches 5 hours. The flight altitude varies from 3 to 5 kilometers.

- Midi. UAVs weighing up to 1 ton, are designed for 15 hours of flight. Such UAVs rise to a height of up to 10 kilometers.

- Heavy drones. Their weight exceeds a ton, devices for long-distance flights lasting more than a day have been developed. They can travel at an altitude of 20 kilometers.

According to the variety of designs, there are 4 main types of UAVs:

- Multi-rotor - multi-rotor drones;
- Fixed wing drone;
- Single rotor drone - unmanned helicopter;
- Hybrid drones.

Multi-rotor drones are the most common types of drones used by professionals and amateurs alike. Such a drone is a flying platform with 3, 4, 6, 8, 12 brushless motors with propellers. So a drone with four motors is called a Quadcopter, with

six - Hexacopter, with eight - Octocopter. In flight, the drone keeps a horizontal position relative to the surface of the earth and can hover over a certain place, move left, right, forward, backward, up and down, as well as rotate around its axis. All actions are performed by changing the thrust on each motor.

The market segment for such devices is diverse, including multi-rotor drones for professional use, such as aerial photography, the price of which can range from \$ 500 to \$ 3000. But there are many hobby models such as amateur drone racing or leisure flying, ranging in price from \$ 50 to \$ 400. Of all types of drones, multicopter drones are the easiest to make and the cheapest.

The main problem with multicopters is that they have to spend a huge part of their energy fighting gravity and stabilizing the craft in the air. Currently, most multi-rotor drones are capable of flying for only 20 to 30 minutes with minimal payload such as a video camera.

Fixed-wing drones are completely different in design from multi-rotor drones. They use a "wing" to fly, and create lift, just like conventional airplanes do. These drones cannot hover in place in the air while fighting gravity. Instead, they can move forward on a given course for as long as their energy source allows.

Most fixed-wing drones have an average flight time of a couple of hours. Gas powered drones can fly for up to 16 hours or more. With their longer flight times and fuel efficiency, fixed-wing drones are ideal for long-range operations (be it mapping or surveillance). But they cannot be used for aerial photography, where the drone must remain stationary in the air for a certain period of time.

Other disadvantages of fixed-wing drones are the higher costs of training personnel in the flight control skills. It is not easy to fly a fixed-wing drone into the air. To launch and lift a fixed-wing drone into the air, either a dedicated "runway" or a catapult launcher is required. To safely land the craft back on the ground, you will also need an airstrip, parachute, or net.

Single rotor drones are very similar in design and to real helicopters. Unlike a multi-rotor drone, a single-rotor drone has one large lead rotor plus a small rotor

on the tail to control the course. Single rotor drones are much more efficient than multi-rotor versions. They have a longer flight time and can even be powered by internal combustion engines.

In aerodynamics, the fewer the number of propellers, the less the total rotation of the object. And this is the main reason why quadcopters (4 propellers) are more stable than octopters (8 propellers). In this sense, single rotor drones are much more efficient than multi rotor drones.

But there are also disadvantages to single rotor drones. These machines, due to their more complex design, have a high cost and operating costs. They also require special training of personnel for management. Large rotor blades are dangerous. Accidents of fatal injuries were recorded by the propeller of a radio-controlled helicopter. For example, multi-rotor drones have never participated in fatal accidents, although it is quite possible to get a scar on the human body from the propeller of a multi-rotor drones.

Hybrid versions combine the advantages of fixed-wing models such as higher flight times with the advantages of propeller-based models - the ability to fly. Hybrid aircraft designs have been in development since the 1960s but have had little success. However, with the advent of new generation sensors (gyroscopes and accelerometers), the hybrid design has received a new life and direction of development.

The design of the unmanned vehicle includes a satellite navigator and a programmable module. If the UAV is used to receive, store and transmit information to the operator's console, a memory card and a transmitter are additionally installed in it.

The design and functionality will vary depending on the purpose of the device. There are drone models that are able to take human commands and respond to them. In such devices, special command receiver modules are installed.

For day-to-day vessels, it is characteristic of wide availability of automatic control systems (ACS) practically in all modes and stages of use. Without such

systems, it is unwisely effective to check the aviation technology for finding the simplest tasks of transportation.

1.2 Description of control systems

An analysis of literary sources shows how on the current day the main UAV will be stuck with a remote flight. Victory of such lithic devices has a number of peculiarities, connected with the permanent stitches of the operator behind the drone's camp in the open space, the transfer of possibilities with the cross-codes and the free supply of high-quality signals to the drive drivers. Tse vimagae vidpovidnoï kvalifikatsiï from the operator. Such a pidhid is a few shortcomings:

- the area of the storage of the lithal apparatuses was surrounded, the wiklikan of the need to receive a call from the operator's post;

- the foldability of the control is due to the direct deposition between the operator and the crash of the drone, which can be brought up to the operator;

- folding of adequate control based on telemetry data.

More promising is UAV control system due to the availability of autonomous navigation annexes and the transfer code value. For any reason, the drone can move in space independently, directly from the operator.

The autonomous mode of the drone is stored from the decile of the main stages, such as being displayed before the next fuel injection, and coming from the onboard self-propelled gun:

1. takeoff from some surface;
2. moving the UAV in the horizontal plane to a given point in space;
3. transition to the freeze mode, which allows for reconnaissance, video recording and (or) perform the necessary measurements;
4. return to the starting point or any other set point and landing.

Obviously, when designing an onboard automatic autonomous flight control system(CS), it is necessary to solve the problem of determining the real coordinates of the drone by processing data from sensors, matching them with the specified in memory, finding control effects on deviations of real coordinates from the specified.

Of particular interest is the UAV stabilization mode, which is characterized by the ability of the drone to hang in the air at a given height and monitor the environment. This mode is convenient to carry out autonomously using the onboard ACS drone. An accelerometer, gyroscope and barometer are installed in the flight controller CS for this function. At the same time, today even the best models of drones have low accuracy of hanging on the point. Deviation in height reaches ± 0.5 m; and in the horizontal plane ± 1.5 m. Development of new algorithms of autonomous management allows to solve the set task more qualitatively.

Recently, the methods of intelligent control of UAVs are becoming more widespread. However, to date, in most cases, the implementation of such control in nondeterministic conditions has a drawback, which is associated with the lack of ability of intelligent CS to adapt to dynamic conditions. Independent operation of the drone in unpredictable conditions is possible with the further development of intelligent CSs. In this case, control by the operator can be carried out at a higher level - at the level of goal setting. However, such methods of controlling the movement of UAVs are poorly developed.

The aircraft, which is controlled at the level of goal setting, must move in a non-deterministic environment, which is characterized by a previously unknown location of obstacles and targets, as well as their mobility. In such conditions, the independent movement of the robot determines the need for dynamic analysis of the situation in the operating environment. Based on the results of such analysis, carried out in the General case with the help of sensory information and the target setting of the operator, the UAV CSs must navigate and control its movement.

Accordingly, there are three types of architectures of motion CSs for UAVs:



1. architecture based on the decomposition of information processing functions in the process of "recognition - modeling - planning - action" (Sensor - Model - Plan - Act, SMPA);
2. reactive (reflex) architecture based on the strategy of purposeful behavior of the UAV, which is produced on the basis of sensor information (sensor based action);
3. hybrid architecture based on a combination of two previous types of architectures.

A typical structural and functional diagram of the SMPA-drone motion CS is presented in Fig. 1.1.

This system controls the movement of the drone by modeling the environment, localization in it, as well as planning, correction and development of trajectories.

Environmental modeling is carried out on the basis of sensory and other information coming from various sources. The environmental model should describe in the dynamics of the location of the drone, obstacles and targets.



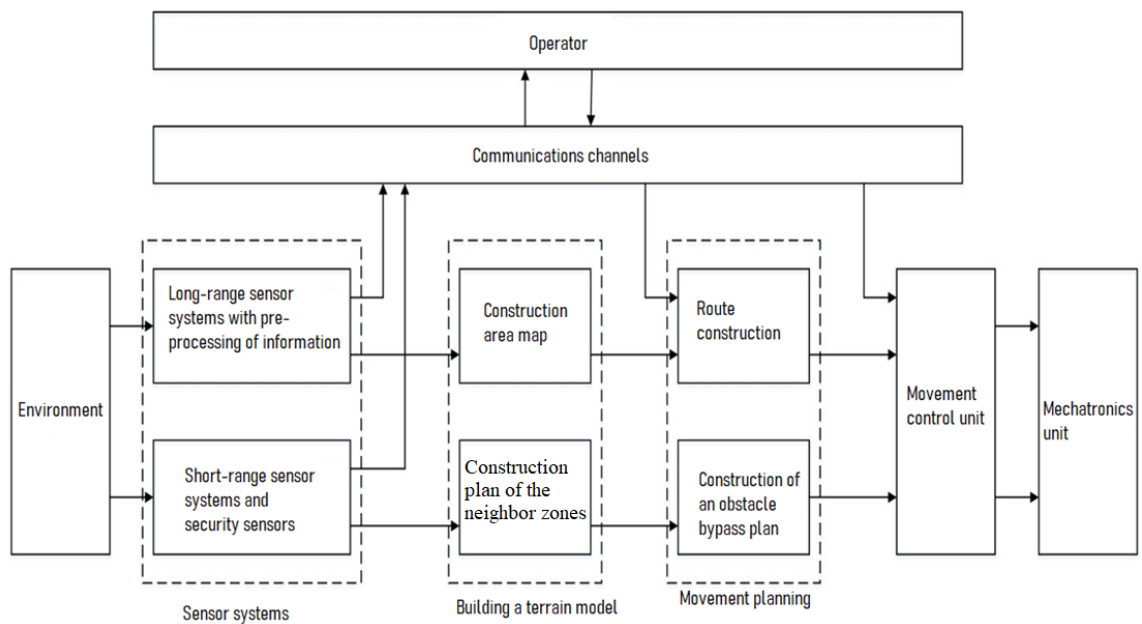

Figure 1.1 - Typical structural and functional diagram of the SMPA-motion CS for UAVs

The task of self-localization of UAVs is closely related to the task of modeling the workspace, because their solutions are interdependent, ie the quality of the solution of one determines the quality of the solution of the other. To solve this problem, methods of path calculus, integral and sensory localization are used. The path calculation method involves the analysis of the accumulated error and in most cases is used in conjunction with the sensory method to eliminate it, as well as to match the characteristics or guidelines in the work environment. The method of integrated navigation involves the implementation of global positioning (GPS) and laser scanning of the environment. When modeling the working space of the UAV distinguish geometric and topological localization. Geometric localization determines the position and orientation of the drone, topological - its relationship with the operating environment [6-11].

To date, there are three main strategies for localization computing:

1. periodic combination of a local model of the environment with a given a priori map;

2. determining the position on the basis of a priori well-known benchmarks;

3. selection of environmental characteristics and assessment of their positions relative to the drone, followed by determination of its resulting movement.

UAV trajectory planning can be based on the following approaches:

1. methods based on the road map, where visibility graphs are used;

2. representation of the map of the environment in the form of a field in a cell, which involves the implementation of Delaunay triangulation, as well as division into square and hexagonal segments, which can be implemented models of probabilistic passage, models with information accumulation, etc .;

3. movement in virtual information fields, which involves the use of heuristic algorithms, as well as algorithms based on the method of potentials;

4. methods of planning the behavior of the movement, where the formed plan is a sequence of behavioral acts, the transition between which is carried out under certain conditions.

In the general case, there are global and local planning. Global planning is based on a terrain map (for example, using GPS, long-range sensor systems), local - based on signals from short-range sensor systems and security sensors received in real time.

1.3 Analysis of elements of aircraft control systems

Aircraft CS - a set of devices, systems and control laws that provide control of the aircraft. In the narrow sense, it is the formation of deviations of the controls for the desired change in the position of the UAV in space or maintaining a given position under the action of various perturbations.



It consists of the main flight CS and the auxiliary CS, which provides a change in the configuration of the aircraft depending on the flight mode. The main CS includes steering systems for roll, pitch and engine channels in manual or automatic modes.

Additional CS includes:

- CS mechanization of the wing (Flaps, interceptors)
- CS by means of aerodynamic balancing (servo compensators, trimmers), chassis and other devices.

Control means the procedure of modifying the characteristics of the movement of the aircraft in the desired orientation in order to achieve the goal. The management process is based on information about the management task (set goal) and the current location of the system. This control process is based on the following main steps:

- obtaining the necessary information about control tasks;
- providing information about the current state of the control object (CO);
- information processing and decision making (control influence);
- implementation of a given decision.

These components are the procedure for controlling the aircraft. The pilot, visually using the readings of the devices, monitors the parameters of the movement of the aircraft in space (direction, speed, etc.). He compares the true values of the characteristics of movement with the established, conducts research, forms a resolution and, performing it, affects the control levers. As a result of this influence, the controls are rejected, which modify the forces and moments operating on the aircraft, and, accordingly, the characteristics of movement in the desired direction.

Due to the distribution of functions between the pilot and automatic devices,



the control procedure is divided into 3 types (types of CS):

- non - automatic (manual);
- semi-automatic or director;
- automatic.

In manual control, all functions for the control of the aircraft (reception and study of data, the formation and implementation of control effects) is performed by the pilot, who rejects directly or with the support of the controls actuator. The CS will be called "manual", if it does not include components that bring to perfection the properties of stability and controllability of the aircraft, and "manual automated" when connecting to it the components of the stability and controllability system.

With automatic control, all functions of the aircraft control are performed by the automatic control system (ACS). The automatic control system includes:

- Stability and controllability system (SCS). It includes dampers, automatic longitudinal and lateral control, balancing machines.
- Angular stabilization system (ASS). These include autopilots designed to stabilize a given angular position of the aircraft relative to the air flow and to solve some problems of piloting the aircraft, such as to perform automatic coordinated turns on the heading.
- Trajectory control system (TCS). It includes machines that perform the tasks of aircraft guidance and route calculation. They are a complex aerobatic navigation complex, coupled with CS.

In semi-automatic control, part of the functions are performed by the pilot, part by automatic devices. A typical example is director regulation. In this control, the reception, data research, control signal generation, as well as automatic control, is performed by the ACS computer, which sends a signal not to the ACS actuator

(steering device), but to the director's aerobatic command. When performing a flight ACS (or pilot) guarantee modification of the characteristics of movement according to the given law.

The control law is a mathematical or logical interdependence between the deviation of the controls and the current and set parameters of the aircraft movement. CO - a device (system) that carries out the technical process and requires specially organized external influences to implement its algorithm.

Aircraft - a device designed to fly in the Earth's atmosphere or outer space to perform a specific task.

The structure and composition of the aircraft CS depend on the type and purpose of the aircraft as a CO. Aircraft is one of the links of a closed control and stabilization system.

Aircraft controls - technical devices that regulate the magnitude and direction of forces and moments acting on the aircraft. Aircraft controls are used to change the angular position of the aircraft body and the position of its center of mass.

Depending on their purpose are distinguished:

- target control bodies: coordinated regulator (stabilizer); anterior horizontal tail; coordinated thrust vector;
- transverse controls: ailerons; elevons, which perform the functions of ailerons; flaperons, which perform the functions of ailerons; interceptors; differential regulator; rotary nozzles or jet rudders.
- road control bodies: steering wheel; auxiliary controlled surfaces in the lower part of the fuselage.
- controls used to increase flight performance: controlled flaps and flaperons; differentiated wing-likeness; interceptors; brake pads; thrust reversal.

- speed controls: motor; brake pads; braking; thrust autoreverse, etc..

In most cases, the same controls are used to change the angular position of the aircraft and the position of its center of mass, while the control of the position of the center of mass of the aircraft is performed by controlling the angular position of the aircraft body.

Controls can be divided into 4 groups:

- Aerodynamic
- Gas-dynamic
- Inertial
- Magnetic

To aerodynamic belong:

- rudder
- elevator
- ailerons

1.4 Analysis of guidance system for unmanned aerial vehicles

Analyzing the CSs, consider a guided and unmanned UAV. If the UAV is unguided and there are no accidental actions during the flight, its trajectory is completely determined by the initial launch conditions and ballistic characteristics. An error at the beginning of the launch of an UAV (for unmanned aircraft) leads to negative results when the desired object is hit.

In a real controlled flight, the magnitude and direction of the speed can vary continuously depending on the position of the controls. Therefore, under fixed initial conditions, a large number of trajectories of the controlled UAV is possible. In order for the given initial conditions to correspond to a certain trajectory, it is



necessary to impose some connections on the process of movement. In real life, such connections are superimposed on the UAVs CS, ie the UAVs motion CS adds an equation that describes the CS.

A CS that is placed on an UAV and receives information before launch is called autonomous.

A CS that receives information during a flight from a command post (control point) is called a telecontrol system.

A CS that receives information during the flight directly from the guidance object is called a homing system.

In addition to the CS on board the UAV must be a device that processes information about the object of guidance and control results, ie devices that determine the deviation of the UAV from the parameters of the theoretical, calculated trajectory, such parameters are called control parameters.

The most common control parameter in homing systems is to change the angular velocity of the target line of sight. The angular velocity ω is changed by the following coordinator of the homing head of the UAV. In telecontrol systems, the control parameter is the amount of deviation of the UAV from the direction line to the guidance object (operator - object). The measurement of this deviation is performed automatically using measuring elements. In autonomous CS there are meters that determine the deviation of the trajectory of the UAV from the specified. These include an inertial system, altimeters, speedometers, etc.

UAV CS have devices that convert control parameter signals. They are a set of amplifiers and various functional converters. Actuators that actuate the rudder of an UAV are the rudder drives.

To ensure full controllability, the UAV is provided with altitude rudder, control and roll.

For two-channel control of an UAV, the equations of ideal communication (excluding perturbations) have the form:

- for homing UAV:

$$\begin{cases} F_1(V, D, D^0, X^0, \dot{X}^0, t) = 0; \\ F_2(V, D, D^0, X^0, \dot{X}^0, t) = 0, \end{cases} \quad (1.1)$$

where D – distance vector to the target object;

- for televised UAV:

$$\begin{cases} F_1(V, D_c, \dot{D}_c, X^0, \dot{X}^0, t) = 0; \\ F_2(V, D_c, \dot{D}_c, X^0, \dot{X}^0, t) = 0, \end{cases} \quad (1.2)$$

- for autonomously controlled UAV:

$$\begin{cases} F_1(V, \gamma, \dot{\gamma}, X^0, \dot{X}^0, t) = 0; \\ F_2(V, \gamma, \dot{\gamma}, X^0, \dot{X}^0, t) = 0. \end{cases} \quad (1.3)$$

Equations (1.1) and (1.3) show that in the process of UAV communications can be superimposed on the velocity vector (\vec{V}), from the distance vector to the object (\vec{D}) and the longitudinal axis (X^0), but all of them ultimately boil down to the need to reverse the velocity vector according to a certain law. However, other connections are possible that provide the required flight mode of the UAV (for example, engine thrust control, altitude and roll control). The connections that determine the direction of the velocity vector of an UAV are called the main ones, all the others are called auxiliary.

The CS of the UAV implements certain guidance methods.

The method of directing UAVs is a certain organization of flight control of an UAV, which ensures that the aircraft hits the desired object and the scalar equations

of control of ideal communication, which is superimposed on the movement of the UAV.

In UAV systems, the guidance relative to the target object is determined by the range vector. To subordinate the range vector to a particular link, it is necessary that the velocity vector of the UAV at any given time has a certain direction, so superimposing the link on the range vector also allows you to indirectly control the direction of the velocity vector of the drone.

Therefore, equation (1.1) (with the connection superimposed on the velocity vector of the UAV) can be rewritten as:

$$\begin{cases} F_1(V, D, t) = 0; \\ F_2(V, D, t) = 0, \end{cases} \quad (1.4)$$

Equation (1.4) includes a range vector because the direction of the velocity vector is given relative to the direction of the desired object, with the connection superimposed on the direction of the longitudinal axis of the UAV relative to the direction of the object, scalar equations will look like:

$$\begin{cases} F_1(D, X^0, t) = 0; \\ F_2(D, X^0, t) = 0, \end{cases} \quad (1.5)$$

The relationship superimposed on the velocity vector is described:

$$\begin{cases} F_1(D, t) = 0; \\ F_2(D, t) = 0, \end{cases} \quad (1.6)$$

Equations (1.4), (1.5), (1.6) are frequent cases of equation (1.1) when F_1 and F_2 do not depend on some arguments.



Consider the typical specific CSs and turn first to homing systems. The number of methods of homing UAVs is well known. Depending on the type of ideal connections, the methods of homing UAVs can be divided into three groups:

- communication is overlaps on the axis of the UAV;
- communication is overlaps on the velocity vector of the center of mass of the UAV;
- the connection is overlaps on the range vector between the UAV and the guidance object.

The homing system is a complex of on-board equipment of an UAV, which generates a control signal in accordance with the equations of ideal connections and turning the steering wheel of an UAV. The structure of homing systems and the form of control laws are diverse. The variety of homing systems is determined primarily by the composition of the meters and the method of guidance used. Self-guidance systems include gauges of relative coordinates of the guidance object and UAV, and their derivatives. The measured values in most cases are control parameters. But in some cases, signals of other meters are also used to form control parameters, in particular gyroscopic meters of the angular position of the UAV relative to some given reference system. In such cases, the control parameters are formed from the signals of the meters by appropriate calculations. In addition to coordinators, the homing system also uses angular velocity meters for UAVs relative to connected axes (speed gyroscopes), roll angle meters (positional or integration gyroscope) and UAV accelerometers in projections on the coordinate axis of the connected system. accelerometers). Various summing amplifiers and filters are used to generate control signals that are fed to the steering wheel drives.

1.4.1 Telecontrol systems.

In the simplest telecontrol systems, the coordinates of the UAV relative to the command post (control operator) are measured. Therefore, in telecontrol,

communication is superimposed directly on the range vector, and the velocity vector is subject to indirect communication.

The structures and laws of control of telecontrol systems are very diverse. Telecontrol systems usually include meters of the actual coordinates of the target object and their derivatives. These meters, which are commonly used as radars, are usually located at the command post. Based on the signals of these meters, the control parameters are determined in accordance with the equations of ideal connections. Devices for generating control parameters in the General case are computers of continuous or discrete type.

To improve the dynamic control characteristics, it is necessary to use signals that depend on the angular velocities of the UAV relative to the connected axes y_1 and z_1 , as well as signals that depend on the normal acceleration of the aircraft in the projections on the connected axes y_1 and z_1 .

High-speed gyroscopes and gyrotrons are used to measure angular velocities, and accelerometers are used to measure UAV accelerations. In addition, in telecontrol systems it is necessary to control the movement of the aircraft relative to the longitudinal axis x_1 , to provide the necessary steering control in accordance with the measured control parameters. Usually telecontrolled aircraft are stabilized at the appropriate value of the roll angle, in particular, at zero, ie $\dot{\gamma} = 0$. But it is possible to control an UAV that rotates about an axis x_1 , that is $\gamma = const$. In this case, a special converter of control signals in accordance with the rotation of the UAV is required. In all these cases, gyroscopic gauges of actual roll angle and angular velocity are required ω_{x_1} aircraft relative to the axis x_1 . Each control channel has corrective filters and summing amplifiers, which are used to generate control signals that are fed to the steering actuators.

The simplest method of aiming telecontrolled UAVs is the three-point method. This method requires that the UAV is always on a straight line that connects the command post to the guidance object (combination method). If in the process of aiming the UAV, the command point maneuvers in such a way that the

range vector of the guidance object moves gradually, remaining parallel to the initial direction, the three-point method provides a parallel approach to the desired object. With a slow movement of the command post to implement this method is very difficult. In this case, use another method - the method of guidance with a warning angle - the angular method. This method requires the angles that determine the directions of the UAV vectors and guidance objects to change according to a given law when aiming the UAV, and the angle between these vectors must be equal to zero. Also, the condition for the UAV to hit the target object at zero angle between these vectors is the equality of the moduli of these vectors. Thus, to implement this method, the operator must measure not only the angular coordinates of the UAV of the desired object, but also the range.

1.4.2 Autonomous systems

Autonomous guidance systems during the flight of an UAV do not receive any information from the guidance object, from the command post, or from any power source (for example, from a beacon), which explains the name of these systems. The position of the guidance object relative to the Earth's surface is assumed to be uncertain. The guidance equipment, which is completely located on board the aircraft, determines its location relative to the earth's surface, calculates the deviation from a given flight path and in accordance with these deviations generates guidance signals.

To determine the location of the aircraft using measuring systems, the principle of operation of which is based on the known laws of mechanics and physical properties of the Earth and the Universe. According to the method of determining the coordinates of the center of mass of an UAV, there are magnetometric, inertial, astronavigation and other measuring systems. Autonomous guidance systems are classified according to the same principle.

The magnetometric system uses the phenomenon of terrestrial magnetism to determine the location of an UAV.

The principle of operation of the inertial system is based on the change of accelerations and the use of inertial properties of gyroscopes.

The astronavigation system is based on the principles of navigation on celestial bodies.

Equipment for autonomous guidance can be a rather complex dynamic circuit, which consists of a large number of different devices.

In some cases, the control of the coordinates of the center of mass of the aircraft can be replaced by the control of its angular coordinates. Gyroscopic devices, such as independent gyroscopes, are used to measure the actual values of the angular coordinates, and the required values of the angular coordinates are set by a software mechanism.

1.4.3 Combined control systems and their areas of application

In most cases, for the most effective use of controlled UAVs, especially if you need a long range, use different combinations of CSs, using some it is possible to get much better results than with only one CS.

The most common combinations of autonomous CSs with other types of systems. This is due to the fact that most CSs enter normal operation not immediately after the launch of the UAV, but after some time, during which the aircraft, if no special measures are taken, becomes unmanageable. For example, it takes some time for a UAV with a command and CS to get into the point of view of the sighting device of the aircraft - the carrier, and a UAV with radio control entered the beam. In such cases, the aircraft after start-up is controlled by an autonomous CS.

When designing combined CSs, we have to face the task of determining the minimum range of transition to homing, which depends on many reasons. It should be selected so that after the transition to homing the following requirements are met:

- the UAV, moving with the maximum aerodynamic overload for a given altitude and flight speed, must provide correction of the error accumulated before

the transition to homing;

- the transients that occur when switching the CS to homing must be completed by the time the UAV reaches the desired object;

- before switching to homing, the power of signals from the guidance object coming to the receiver of the UAV homing system must be sufficient to reliably capture the desired object in range and angular coordinates.

The accuracy and reliability of different CSs can be significantly exceeded if you use several parallel channels that change the same control parameters. Such parallel circuits can have both the simplest meters and entire systems that provide control duplication. For example, to ensure the reliability of the homing system, you can use a combination of radar and optical coordinators, working in parallel and ensuring the formation of the same control parameters. In this case, in case of failure of one of the coordinators, the work of the management system will be provided by another coordinator.

To ensure the reliable operation of autonomous CSs for long-range UAVs, you can use a combination of inertial and astronavigation control equipment operating in parallel.

The big disadvantage of combined CS is the complexity and high cost of the equipment, as well as their significant weight and size. Therefore, the use of combined systems is justified only in cases where one type of CS does not provide a satisfactory solution.

1.5. Defining the requirements for the automatic control system

During the control of the aircraft there are aerodynamic forces and moments. As the regulating factors allowing to influence the aircraft for control of its movement, angles of deviation on a pitch, a yaw, a roll and engine thrust are used..

The UAV as an object of control is a complex dynamic system due to the presence of a large number of interconnected parameters and complex cross-interactions between them. Complex motion is often divided into the simplest

types: angular motion and motion of the center of mass, longitudinal and lateral motion. Controls that create control effects can be divided into two groups: longitudinal controls that provide movement in the longitudinal plane; lateral movement controls that provide the necessary nature of the change of roll angles, sideslip and yawing.

Such a distribution of controls is conditional, as it is possible to cite flight modes in which the controls have cross-influences on other movements. At the same time, this approach allows you to identify the main functions of specific bodies and control channels and independently solve many relatively simple and practical tasks.

Four control channels are required to ensure full automation of flight control:

- engine control channel (thrust);
- pitch control channel;
- roll control channel;
- yaw control channel.

The engine control channel adjusts the thrust according to the specified flight program. The next three control channels provide the required angular position of the device in space. Due to the complexity of the UAV study, this paper will consider the longitudinal control channel and stabilization of the UAV by the pitch channel.

The CS of the aircraft is used to ensure the flight on a given trajectory by creating the necessary aerodynamic forces and moments on the wing and plumage. There are three types of CSs - manual, semi-automatic and automatic.

In the manual CS, the pilot-operator, assessing the situation, ensures the production of control effects and with the help of command levers through the control panels deflects the steering surfaces, holding them in the desired position.

In a semi-automatic system, the control signals of the pilot-operator are converted and amplified by various machines and amplifiers, providing optimal characteristics of stability and controllability of the aircraft.



Automatic systems provide full automation of individual stages of the flight, freeing the pilot-operator from direct participation in the control of the aircraft.

In the process of adjusting the control by angles or altitude of the aircraft in the automatic system, the input of the controller receives the desired values of angles or heights, and the output variables of the controller will reject the angles of the elevons on the pitch, roll and yaw. Requirements for the CS:

- minimum transition time
- minimal overregulation (aperiodic process).

It is necessary that the CS provides the specified parameters of the transient process.

The task set in this thesis requires the study of the following issues:

- substantiation of the mathematical description of the CO.
- determination of the optimal structure of the CS on the basis of analytical methods, the theory of optimal systems.
- determination of approximate values of CS parameters on the basis of analytical methods and modeling;
- implementation of the control laws by the CO.
- determination of optimal values of CS parameters taking into account the set range of application conditions.

The task of the synthesis of the aerobatic system is the choice of the structure and parameters of the control channels that provide a given quality of flight control, based on the dynamic properties.

The main task is to create a fully automatic ACS, which will control the deviation of the control surfaces for the flight of the aircraft on the desired trajectory. It should be noted that this paper will study the UAV, which is in service in the Ukrainian army unmanned aircraft complexes UAC-MP-1 Spectator (Fig. 1.2), the calculations will use its key characteristics such as [12]:

- Wingspan: 3 m
- Maximum takeoff weight: 5,5 kg

- Operating flight speed: 60 km/h

Other characteristics that will be used for calculations will be given in Appendix A.



Fig. 1.2 UAC-MP-1 Spectator

CHAPTER 2. DEVELOPMENT OF A MATHEMATICAL MODEL OF AN UNMANNED AIRCRAFT VEHICLE MOVEMENT

2.1 Mathematical model of unmanned aerial vehicle movement

To consider the dynamic processes in the control circuits of the aircraft, it is necessary to have a mathematical model of the CO. The mathematical model must, firstly, correctly reflect the basic properties of a real object, and secondly, be simple enough for research.

Depending on the tasks assigned to the automatic control circuit, the same UAV can be represented by mathematical models of different complexity and completeness of the description of the real properties of the object. In the vast majority of cases, it is permissible to divide the spatial motion of the aircraft into lateral and longitudinal components, which greatly simplifies the relevant mathematical models. In addition, for many flight modes, the equations of longitudinal and lateral motion can be further simplified and linearized. In this paper, a variant of the longitudinal motion of the aircraft will be considered.

Mathematical model of spatial motion of the aircraft is the basis for obtaining simplified mathematical models that are used in the analysis of automatic control circuits [13]. The general theory of aircraft motion is based on well-known theorems of classical mechanics. The motion characteristics are determined taking into account the forward motion of the aircraft's center of mass and the rotational motion relative to the center of mass. The equations of flight dynamics of the aircraft are recorded in certain coordinate systems. Choosing the correct coordinate system can greatly simplify the mathematical description of the CO.

When solving the problem of aircraft flight control, it is recommended to use fixed and movable right rectangular Cartesian coordinate systems.

<i>ACIC DEPARTMENT</i>				<i>NAU 21 0618 000 EN</i>			
<i>Performed</i>	<i>Maksymchuk M. V.</i>			<i>AUTOMATED CONTROL SYSTEM FOR UNMANNED AERIAL VEHICLE</i>	<i>N.</i>	<i>Page</i>	<i>Pages</i>
<i>Supervisor</i>	<i>Tupitsyn M.F.</i>						
<i>Consultant</i>							
<i>S. controller</i>	<i>Tupitsyn M.F.</i>						
<i>Dep. head</i>	<i>Sineglazov V. M.</i>						
					<i>431 151</i>		

Fixed coordinate systems, in which the axes and origin of coordinates are fixed relative to the Earth, are used as a reference system for velocities, accelerations, and LA movements. As a fixed coordinate system, the most commonly used normal coordinate system is $O_oX_gY_gZ_g$, whose O_oY_g axis is directed up the local vertical, and the directions of the O_oX_g and O_oZ_g axes are selected according to the task.

Moving coordinate systems, the beginning of which is located in the center of mass of the LA (hence the second name aircraft-centric coordinate systems), are usually used to write the equations of motion of the UAV in this case.

The most commonly used moving systems are: normal, connected, velocity, and trajectory coordinate systems.

The normal coordinate system $OX_gY_gZ_g$ – is a moving coordinate system with the OY_g axis pointing up the local vertical, and the direction of the OX_g and OZ_g axes is selected according to the task.

The connected coordinate system $OXYZ$ - is a mobile coordinate system whose axes are fixed relative to the LA. The longitudinal axis OX is located in the plane of symmetry of the LA and is directed from the tail to the nose of it. The normal axis OY is located in the plane of symmetry of the LA and is directed to the upper part of it. The transverse axis OZ is perpendicular to the plane of symmetry of the LA and is directed to its right side. The axes of the connected coordinate system usually coincide with the main axes of inertia of the aircraft.

The speed coordinate system $OX_aY_aZ_a$ - is a mobile coordinate system whose speed axis OX_a coincides with the direction of the airspeed vector \vec{V} (the speed of the LA relative to the air environment), the lift axis OY_a is located in the plane of symmetry of the aircraft and is directed to the upper part of it, and the side axis OZ_a complements the axis OX_a i OY_a to the high-speed coordinate system.

The position of the previous described coordinate systems relative are determined by three angles: yaw angle ψ , pitch angle ϑ , roll angle γ , position of

the airspeed vector LA \vec{V} is characterized by the angle of attack α and the slip angle β , inclination angle of the trajectory θ , flight-path angle Θ , track angle Ψ and so on Fig. 1.1

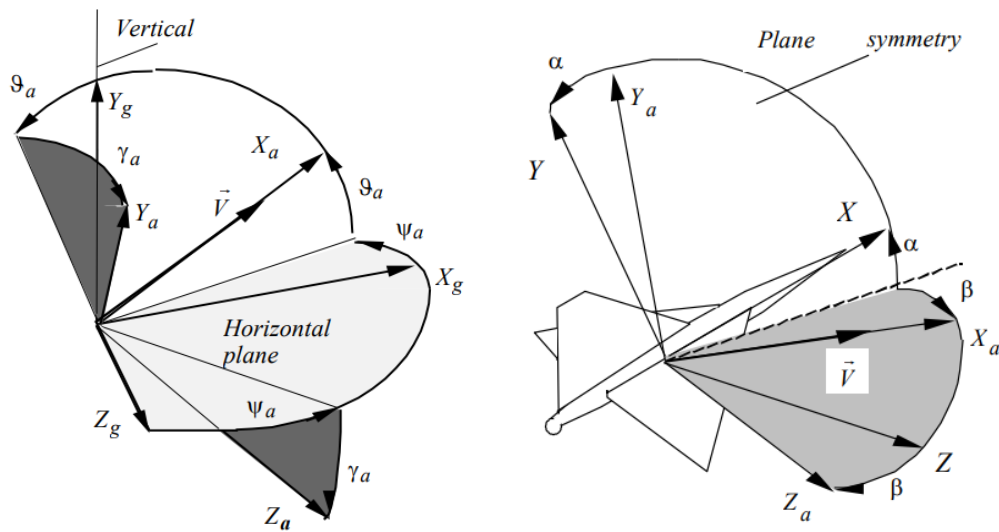

Fig. 2.1

The Fig. 2.1 illustrates the mutual angular position of mobile coordinate systems. Coordinate systems are located in the nodes of the diagram, and the branches show angular coordinates that characterize the relative position of individual coordinate systems.

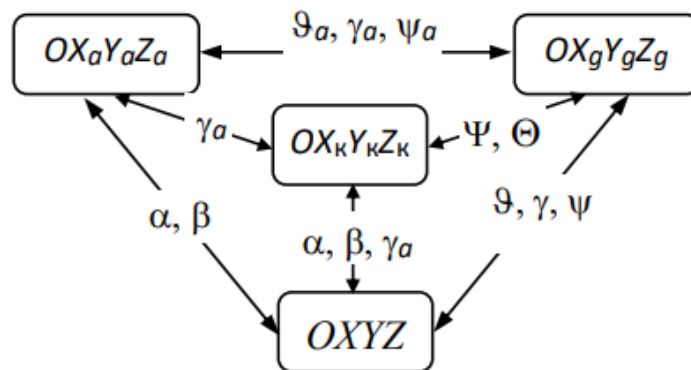

Fig. 2.2

Sometimes it's possible to consider a spatial motion as a longitudinal and a lateral motion separately. The equations describing aircraft translation along the X_a , Y_a axes, and rotation about Z_a axis belong to longitudinal motion. The equations describing aircraft translation along the Z_a -axis, and rotation about Y_a , X_a -axes

belong to lateral motion. There are three kinds of interaction between longitudinal and lateral motions.

1. Aerodynamic interaction is caused by dependence on aerodynamic coefficients entering the equations of longitudinal motion on parameter of lateral motion and vice versa.

2. Inertial interaction is caused by the addends $(I_y - I_x)\omega_x\omega_y$ and $(I_x - I_z)\omega_x\omega_z$ in the equations of moments. This interaction becomes more evident at a high roll angular velocity.

3. Kinematic interaction is caused by relative turns of different coordinate systems used for the description of aircraft spatial motion. This interaction doesn't have any physical explanation. The example of such an interaction is conversion of the angle of attack α into the side-slip angle β and vice versa during aircraft rotation about the X-axis.

Uncovering the dependencies of aerodynamic forces and moments on flight parameters, we'll also get the additional relationships:

$$Y_a = c_{y_a} qS; X_a = c_{x_a} qS; Z_a = c_{z_a} qS;$$

$$M_y = m_y \bar{q}Sl; M_x = m_x \bar{q}Sl; M_z = m_z \bar{q}S b_A; P = P(H, V, \delta_{g.s}),$$

where $c_{y_a} = c_{y_a}(\alpha, V, \delta_e)$, $c_{x_a} = c_{x_a}(\alpha, V)$, $c_{z_a} = c_{z_a}(\beta, \delta_\rho)$ – airframe aerodynamic force coefficients (lift coefficient, drag coefficient, side-force coefficient); $m_x = m_x(\beta, \omega_x, \omega_y, \delta_r, \delta_a)$, $m_y = m_y(\beta, \omega_x, \omega_y, \delta_r, \delta_a)$, $m_z = m_z(V, a, \dot{\alpha}, \omega_z, \delta_e)$ – moment coefficients; $\delta_{g.s}$ – deviation of gas sector; δ_e – deviation of elevator; δ_a – deviation of ailerons, δ_r – deviation of rudder, S – wing area; b_A – wing span; l – characteristic dimension; \bar{c} – wing chord. Factor $\rho V^2/2$ is called the dynamic pressure and could be designated as q .

Strictly speaking, moments of pitch and yaw depend on from next parameters $M_y(V, H, \beta, \omega_x, \omega_y, \delta_r, \delta_a, \dot{\beta}, \dot{\delta}_r)$, $M_z(V, H, a, \dot{\alpha}, \omega_z, \delta_e, \dot{\delta}_e)$.

However, in most cases an influence of angular velocities $\omega_x, \omega_y, \omega_z$ and time derivatives $\alpha, \beta, \delta_a, \delta_r, \delta_e$ on moments is secondary in comparison with

the influence of angles $\alpha, \beta, \delta_a, \delta_r, \delta_e$. Therefore, it's entirely natural to make an assumption that $M_z = (V, H, \alpha, \delta_e), M_y = (V, H, \beta, \delta_r, \delta_a)$.

$M_z = (V, H, \alpha, \delta_e) = 0; M_y = (V, H, \beta, \delta_r, \delta_a) = 0$ – are so-called “balanced curves”.

Closed loop system of equations, which describes the aircraft longitudinal motion, may be extracted from the total system of equations, if the parameters of lateral motion and angles of control deviation $\delta_a, \delta_r, \gamma = 0$ are equal to zero:

$$\begin{aligned}
 m\dot{V} &= P \cos \alpha - X_a - mg \sin \theta; \\
 mV\dot{\theta} &= P \sin \alpha + Y_a - mg \cos \theta; \\
 I_z \dot{\omega}_z &= M_z; \\
 \dot{X}_g &= V \cos \theta \\
 \dot{\vartheta} &= \omega_z; \\
 \alpha &= \vartheta - \theta; \\
 \dot{Y}_g = \dot{H} &= V \sin \theta;
 \end{aligned} \tag{2.1}$$

Kinematical relation $\alpha = \vartheta - \theta$, which is obtained from the first geometrical equation after its transformation by the equation of trigonometric fractions arguments subtraction.

The last equation doesn't influence on the other equations of the system, so the system may be considered neglecting it.

Due to dynamics of the aircraft longitudinal motion, which is considered above, for the analysis of the automatic control contours; we'll use the model of short-period motion only, i.e. neglecting the change of velocity vector value.

Consider the short-period aircraft motion only, and taking into account the most essential dependences of aerodynamic forces and moments, it is possible to make the following assumptions obtained simplified equations of the longitudinal aircraft motion:

– taking into account small and insignificant changing of the attack angle of cruise regime, we'll assume that $\sin \alpha \approx 0, \cos \alpha \approx 1$;

- the flight velocity (the airspeed) at short-period motion doesn't change ($V=V_0 = \text{const}$), thus, the first equation of the system is degenerated into identity;
- the elevator deviation doesn't change the lift, it only creates the moment M_z , so $Y_a \neq f(\delta_e)$;
- engine thrust is the constant value, so $P=\text{const}$ ($\delta_{g,s} = \text{const}$);
- dependence of the aerodynamic moment from downwash is not significant, so $M_z \neq f(\dot{\alpha})$;
- at small altitude deviation it is possible to assume that $\rho = \rho_0$. In this case the last equation of the previous equations system doesn't influence the others, therefore they may be considered without it. The values of forces and moments don't depend on air density and the flight velocity change:

$$Y_a = c_{y_a}(\alpha, \delta) \frac{\rho_0 V_0^2}{2} S; M_z = m_z(\alpha, \delta, \omega_z, \delta_e) \frac{\rho_0 V_0^2}{2} S b_A,$$

and output system of equations of the longitudinal motion will be presented as:

$$\begin{aligned} mV_0 \dot{\Theta} &= P \sin a + Y_a - mg \cos \Theta \\ I_z \dot{\omega}_z &= M_z; \\ \dot{\vartheta} &= \omega_z; \\ \dot{H} &= V \sin \Theta, \\ \dot{X}_g &= V \cos \Theta \\ \alpha &= \vartheta - \Theta. \end{aligned} \tag{2.2}$$

2.2 Linearization of the unmanned aerial vehicle longitudinal model

The linearization of the system of motion equations is based on the Taylor series decomposition of a function with the rejection of all terms above the first order of smallness in the vicinity of certain values of the function arguments, in our case in the vicinity of values corresponding to undisturbed motion.

The result of linearization of the system of nonlinear differential equations is a system of linear (linearized) differential equations in deviations (increments), which allows to calculate deviations from the equilibrium values of motion parameters (ie from their values for undisturbed motion).

The nonlinear system of differential equations describing the longitudinal motion of the aircraft has the form (2.1). This mathematical model of longitudinal motion of the aircraft can be used for simplified modeling of motion in the vertical plane of aircraft that do not rotate around the longitudinal axis, and therefore cross-links in them are weak (eg, aircraft, rockets that do not rotate on a roll, etc.).

But most missiles control the flight with the help of aerodynamic rudders without the ability to influence the magnitude and direction of the thrust vector. This makes it possible to effectively control only 5 of the 7 parameters of longitudinal motion - angles ϑ , α and θ angular velocity ω_z and flight altitude H . That is why when developing a mathematical model of such aircraft as CO in the state space, it is advisable to describe the dynamics of these five parameters of motion at a given value of speed, thrust, mass and moment of inertia. Next, we will consider a mathematical model for the problem of controlling height, angle of attack, pitch angle and trajectory at a given speed and thrust.

The initial system of nonlinear equations of motion for the problem of controlling height, angular velocity around the transverse z axis, pitch angle, attack and trajectory at a given value of velocity and thrust is obtained from the system (2.1) assuming that $\dot{V} = 0$; $V = \text{const}$; $\dot{P} = 0$; $P = \text{const}$, and rejecting the equation for \dot{V} i \dot{P} . Then there are 5 equations that describe the longitudinal motion of the UAV.

As is known, a system of differential equations is called linear if these equations have unknown functions and their derivatives are linear. In other words, linear equations should not include non-unit powers of unknown functions and their derivatives, as well as mixed products of unknown functions and their derivatives. Otherwise, the system of differential equations is nonlinear [14].

2.2.1 Disturbed and undisturbed movement

An undisturbed trajectory is a theoretical trajectory that corresponds to a specific equation of controlled motion of an aircraft with nominal values of parameters of the apparatus and CS, given initial conditions, a certain target

maneuver, standard atmospheric parameters, etc. Accordingly, undisturbed motion is motion on undisturbed trajectory. Actual trajectories always differ from theoretical ones not only because the dynamic properties of aircraft and ACS are described by the accepted equations only approximately, but also because of the action on aircraft and ACS of a number of random perturbing factors.

To linearize the equations of motion, all kinematic parameters of motion are represented by control effects in the form of the sum of their values in undisturbed motion and deviations of these parameters from undisturbed values.:

$$\begin{aligned}
 V(t) &= V_*(t) + \Delta V(t); \\
 \theta(t) &= \theta_*(t) + \Delta\theta(t); \\
 \alpha(t) &= \alpha_*(t) + \Delta\alpha(t); \\
 \omega_z(t) &= \omega_{z*}(t) + \Delta\omega_z(t); \\
 \vartheta(t) &= \vartheta_*(t) + \Delta\vartheta(t); \\
 H(t) &= H_*(t) + \Delta H(t); \\
 P(t) &= P_*(t) + \Delta P(t); \\
 \delta_e(t) &= \delta_{e*}(t) + \Delta\delta_e(t);
 \end{aligned} \tag{2.3}$$

Here and hereafter the index "*" denote the value of the kinematic parameters in undisturbed motion. Values $\Delta V(t)$, $\Delta\theta(t)$, ... $\delta_e(t)$, representing the difference between the kinematic parameters in perturbed and undisturbed motion, we will call the increments of kinematic parameters [15].

2.2.2 Linearization of the obtained system of equations of unmanned aerial vehicle longitudinal motion

1st equation of the system (2.2):



$$\begin{aligned}\Delta\dot{\theta} &= Q_{1\theta} * \Delta\theta + Q_{1a} * \Delta a + Q_{1\delta} * \Delta\delta_e; \\ Q_{1\theta} &= \frac{g * \sin\theta_*}{V_*}; \\ Q_{1a} &= \frac{c_y^a * \rho * S * V_*}{2 m_*} + \frac{P_* * \cos a_*}{m_* V_*}; \\ Q_{1\delta} &= \frac{c_y^\delta * \rho * S * V_*}{2 m_*};\end{aligned}\tag{2.4}$$

2nd equation of the system (2.2):

$$\begin{aligned}\Delta a &= Q_{2\theta} * \Delta\theta + Q_{2a} * \Delta a + Q_{2\omega_z} * \Delta\omega_z + Q_{2\delta} * \Delta\delta_e; \\ Q_{2\theta} &= -\frac{g * \sin\theta_*}{V_*}; \\ Q_{2a} &= -\frac{c_y^a * \rho * S * V_*}{2 m_*} - \frac{P_* * \cos a_*}{m_* V_*}; \\ Q_{2\omega_z} &= 1; \\ Q_{2\delta} &= -\frac{c_y^\delta * \rho * S * V_*}{2 m_*};\end{aligned}\tag{2.5}$$

2rd equation of the system (2.2):

$$\begin{aligned}\Delta\dot{\vartheta} &= Q_{3\omega_z} * \Delta\omega_z; \\ Q_{3\omega_z} &= 1;\end{aligned}\tag{2.6}$$

4th equation of the system (2.2):

$$\begin{aligned}\Delta\omega_z &= Q_{4a} * \Delta a + Q_{4\omega_z} * \Delta\omega_z + Q_{4\delta} * \Delta\delta_e; \\ Q_{4a} &= \frac{m_z^a * \rho * S * V_*^2 * l}{2 I_{z_*}}; \\ Q_{4\omega_z} &= \frac{m_z^{\omega_z} * \rho * S * l_*^2 * V_*}{2 I_{z_*}}; \\ Q_{4\delta} &= -\frac{m_z^\delta * \rho * S * V_*^2 * l}{2 I_{z_*}};\end{aligned}\tag{2.7}$$

5th equation of the system (2.2):

$$\begin{aligned}\Delta H &= Q_{5\theta} * \Delta\theta; \\ Q_{5\theta} &= V_* \cos \theta_*.\end{aligned}\quad (2.8)$$

Thus, the linearized system of equations of motion (2.2) can be written as follows:

$$\begin{aligned}\Delta\dot{\theta} &= Q_{1\theta} * \Delta\theta + Q_{1a} * \Delta a + Q_{1\delta} * \Delta\delta_e; \\ \Delta a &= Q_{2\theta} * \Delta\theta + Q_{2a} * \Delta a + Q_{2wz} * \Delta\omega_z + Q_{2\delta} * \Delta\delta_e; \\ \Delta\dot{\vartheta} &= Q_{3wz} * \Delta\omega_z; \\ \Delta\omega_z &= Q_{4a} * \Delta a + Q_{4wz} * \Delta\omega_z + Q_{4\delta} * \Delta\delta_e; \\ \Delta H &= Q_{5\theta} * \Delta\theta;\end{aligned}\quad (2.9)$$

Making the following notations:

$$X = \begin{cases} \Delta\theta \\ \Delta a \\ \Delta\vartheta \\ \Delta\omega_z \\ \Delta H \end{cases}; A = \begin{cases} Q_{1\theta} & Q_{1a} & 0 & 0 & 0 \\ Q_{2\theta} & Q_{2a} & 0 & Q_{2wz} & 0 \\ 0 & 0 & 0 & Q_{3wz} & 0 \\ 0 & Q_{4a} & 0 & Q_{4wz} & 0 \\ Q_{5\theta} & 0 & 0 & 0 & 0 \end{cases}; B = \begin{cases} Q_{1\delta} \\ Q_{2\delta} \\ 0 \\ Q_{4\delta} \\ 0 \end{cases}; u = \Delta\delta_e.\quad (2.10)$$

then mathematical model of the aircraft as CO in the state space can be written by following:

$$\dot{X} = A * X + B * u;\quad (2.11)$$

where the elements of the matrices of the object A and the control matrix B, as well as the state vector X and the control vector u are defined by expressions (2.4-2.9). This form of description of the aircraft as CO is the source when calculating the flight CS using the methods of modern linear ACS.

In the same way you can get a system of differential equations of perturbed motion, which describes the longitudinal motion in increments:

$$\begin{aligned}
\frac{d\Delta V}{dt} &= \frac{P^V - X^V}{m} \Delta V - \frac{P a + X^a}{m} \Delta a - g \cos \theta \Delta \theta - \frac{X^{\delta_e}}{m} \Delta \delta_e + \frac{X_g}{m}; \\
\frac{d\Delta \theta}{dt} &= \frac{P^V a - Y^V}{mV} \Delta V - \frac{P + Y^a}{mV} \Delta a + \frac{g \sin \theta}{mV} \Delta \theta + \frac{Y^{\delta_e}}{mV} \Delta \delta_e + \frac{Y_g}{mV}; \\
\frac{d\Delta \omega_z}{dt} &= \frac{M_z^V}{I_z} \Delta V \frac{M_z^V}{I_z} \Delta a + \frac{M_z^{\omega_z}}{I_z} \Delta \omega_z + \frac{M_z^{\delta_e}}{I_z} \Delta \delta_e + \frac{M_{zB}}{I_z}; \\
\frac{d\Delta \vartheta}{dt} &= \Delta \omega_z; \\
\Delta a &= \Delta \vartheta - \Delta \theta; \\
\frac{d\Delta x}{dt} &= \cos \theta \Delta V - V \sin \theta \Delta \theta; \\
\frac{d\Delta H}{dt} &= \sin \theta \Delta V + V \cos \theta \Delta \theta,
\end{aligned} \tag{2.12}$$

So let's number the variables and perturbations as follows:

0	1	2	3	4	5
V	ϑ	α	δ_e	θ	$X_g, Y_g, M_{z\delta}$

Assign a corresponding number to each of equations (2.12). For example, an equation that describes the change $\Delta \alpha$ will receive №2. The first index corresponds to the number of the equation, the second - the number of increments.

Obviously, the first four equations of system (2.12) can be investigated independently of the kinematic equations that describe the change Δx and ΔH since these variations are not included in the first equations. The system of equations (2.12) can be written, using the abbreviated expressions of the coefficients of the equations to simplify the notation. Before that, exclude variations $\Delta \omega_z$ using the equation:

$$\frac{d\Delta \vartheta}{dt} = \Delta \omega_z.$$

Then the equation of longitudinal motion (2.12) takes the form:



$$\begin{aligned}
\frac{d\Delta V}{dt} + \alpha_{00}\Delta V + \alpha_{02}\Delta a + \alpha_{04}\Delta\theta &= -\alpha_{03}\Delta\delta_e + \alpha_{05}X_g; \\
\alpha_{10}\Delta V + \frac{d^2 \Delta\vartheta}{dt^2} + \alpha_{12}\Delta\alpha + \alpha_{11}\frac{d \Delta\vartheta}{dt} + \alpha_{12}'\frac{d \Delta\alpha}{dt} &= \\
&= -\alpha_{13}'\frac{d \Delta\delta_e}{dt} - \alpha_{13}\Delta\delta_e + \alpha_{15}M_{zB}; \\
\alpha_{40}\Delta V + \alpha_{42}\Delta a + \alpha_{44}\Delta\theta - \frac{d \Delta\theta}{dt} &= \alpha_{43}\Delta\delta_e + \alpha_{45}Y_g; \\
-\Delta\vartheta + \Delta\theta + \Delta a &= 0,
\end{aligned} \tag{2.13}$$

Coefficients α_{ik} related to the aerodynamic and design characteristics of the aircraft. These coefficients are called dynamic coefficients and characterize the important dynamic properties of the aircraft [16]. The input data for determining the dynamic coefficients are the design and geometric parameters of the UAV, and its characteristics. Using this system of equations (2.13), all the transfer functions that characterize the longitudinal perturbed motion of the UAV can be determined, but to compile the transfer function, dynamic coefficients first must be calculated.

In the future, the UAV will be considered as a link in the CS, in which the input action is an increase in the deviation of the controls, and the output values are an increase in the parameters of the UAV, in this case the pitch angle. The dynamic properties of the aircraft as part of the CS will be characterized by the reactions of the UAV to the input actions of the two main types:

- 1) Step deviation of controls (Transient function)
- 2) Harmonic deviation of controls (Frequency characteristics)

The response of the UAV to the step deviation of the controls is approximate to the actual response of the UAV to the deviation of the controls, which is carried out using the actuator.

UAV response to harmonic deflection of controls $\delta(t) = \delta_0 \sin \omega_d t$, where δ_0 – oscillation amplitude, characterizes the ability of the UAV to monitor the deviation of the controls.

To characterize the general properties of perturbed motion, the concept of UAV stability is used. The UAV is called stable if its increments go to zero, ie attenuate.

2.3 Control object balancing

Before synthesizing a CS, you need to find the values of the parameters of the CO at which it will be in equilibrium. At zero values of the angle of attack and the deflection of the rudders, the CO will fall down, because the lifting force is not created, and the force of gravity G causes a negative vertical acceleration. Therefore, it is necessary to find such balancing values of deviation of rudders of height which will lead to emergence of an angle of attack that will cause a single vertical overload. In this case, the angle of attack and deflection of the rudders in total should create zero pitch, so that the CO is balanced in angular velocity around the lateral axis.

To obtain the balancing values of the deviation of the rudder and the angle of attack, it is necessary to make the following balancing equations: the sum of the projections of all forces on the Y axis is zero and the sum of the projections of the moments on the lateral axis is zero. These equations have the form (2.14):

$$\begin{aligned}\Sigma Y_c &= 0; \\ \Sigma M_z &= 0,\end{aligned}\tag{2.14}$$

Determining the balancing angle of attack α_{bal} and the angle of deviation of the elevator δ_{bal} at single overload $n_y = 1$ carried out from a system of equations (2.15):

$$\begin{aligned}m_z^a a_{bal} + m_z^\delta \delta_{bal} &= m_z; \\ C_y^a a_{bal} + C_y^\delta \delta_{bal} &= C_y;\end{aligned}\tag{2.15}$$

From the system of equations (2.15) can be obtained:



$$a_{bal} = \frac{mg}{qS \left(C_y^a - \frac{C_y^\delta m_z^a}{m_z^\delta} \right)}; \quad (2.16)$$

$$\delta_{bal} = -\frac{m_z^a}{m_z^\delta} a_{bal},$$

According to the aerodynamic expressions for the UAV, it is possible to calculate the balancing deviation of the rudders and the balancing angle of attack. We accept the equilibrium value of the speed of 60 km / h. Substituting the values of aerodynamic coefficients from Annex A, can be calculated the values of the balancing angle of attack and the balancing angle of deviation of the elevators:

$$a_{bal} = \frac{5.5 * 9,8}{1.1745 * 60 * 60 * 0.07 \left(0.3224 - \frac{0.075 * (-0.077)}{-0.036} \right)} = 1,99^\circ \quad (2.17)$$

$$\delta_{bal} = -\frac{-0.0772}{-0.0367} * 1.99 = -4,18^\circ$$

2.4 Calculation of dynamic coefficients and corresponding transfer functions

To develop the transfer function, you must first calculate the dynamic coefficients. The input data for determining the dynamic coefficients are the design and geometric parameters of the UAV, its characteristics and the results of calculations of the flight path. To determine the coefficients in the linearized equations of UAV motion (2.18), it is necessary to know the undisturbed motion relative to which the linearization was performed. According to [17], dynamic coefficients are calculated.

$$\begin{aligned}
a_1 &= -\frac{M_z^{\omega_z}}{I_z} = -\frac{m_z^{\omega_z} q S b_A}{I_z}; \\
a_2 &= -\frac{M_z^a}{I_z} = -\frac{57.3 m_z^a q S b_A}{I_z}; \\
a_3 &= -\frac{M_z^\delta}{I_z} = -\frac{57.3 c_z^\delta q S b_A}{I_z}; \\
a_4 &= \frac{Y_a + P}{m V} = \frac{57.3 c_y^a q S + P}{I_z}; \\
a_5 &= \frac{Y_{\delta b}}{m V} = \frac{57.3 c_y^\delta q S}{m V};
\end{aligned} \tag{2.18}$$

Coefficient a_1 – characterizes the aerodynamic damping of the aircraft.

Coefficient a_2 – characterizes the static stability of the aircraft. In order for a UAV to be statically stable it is necessary that the coefficient $a_2 > 0$.

Coefficient a_3 – characterizes the efficiency of the rudders.

Coefficient a_4 – is an increase in the angular velocity tangent to the trajectory, which is caused by the deviation of the angle of attack per unit.

Coefficient a_5 – is an increase in the angular velocity of the angular velocity tangent to the trajectory, which is caused by the deviation of the controls per unit of measurement (at a constant angle of attack).

After calculating the dynamic coefficients, it is necessary to calculate the transfer function according to the a priori analytical model. In general, the transfer function of the UAV for flight altitude control can be represented as follows:

$$\frac{H(s)}{\delta(s)} = K \frac{1}{T^2 s^2 + 2\xi T s + 1} * \frac{1}{s} * \frac{1}{s} \tag{2.19}$$

where:

T – UAV time constant,

ξ – relative damping factor,

K – UAV transfer coefficient.

With the help of dynamic coefficients, the components of the transfer function are calculated [18]:

$$\begin{aligned} T &= \frac{1}{\sqrt{a_2 + a_1 a_4}} \\ \xi &= \frac{a_1 + a_4}{2\sqrt{a_2 + a_1 a_4}} \\ K &= \frac{-a_4 a_3 + a_2 a_5}{a_2 + a_1 a_4} V \end{aligned} \quad (2.20)$$

Thus, it is possible to obtain the transfer function of the aircraft by the Laplace operator and investigate it using the programming and modeling environment MATLAB [19] and MATLAB/Simulink [20]. The calculation of the values of the dynamic coefficients and the values of the transfer function will be considered in CHAPTER 4.



CHAPTER 3. SYNTHESIS OF THE CONTROL SYSTEM FOR THE LONGITUDINAL MOTION OF THE UNMANNED AERIAL VEHICLE

3.1 Development of structural diagram of unmanned aircraft vehicle Control System

The analysis of UAV CSs committed in the chapter 1 allows to formulate the requirements that the UAV autonomous CS must meet, and on this basis to determine its functions and develop a block diagram.

The structural diagram (Fig. 3.1) of the UAV CS consists of a flight controller, a trajectory control unit, a drone mechatronics unit, a sensor unit, a radio modem, a satellite navigation unit, homing head, a motion coordination unit, and a ground control station.

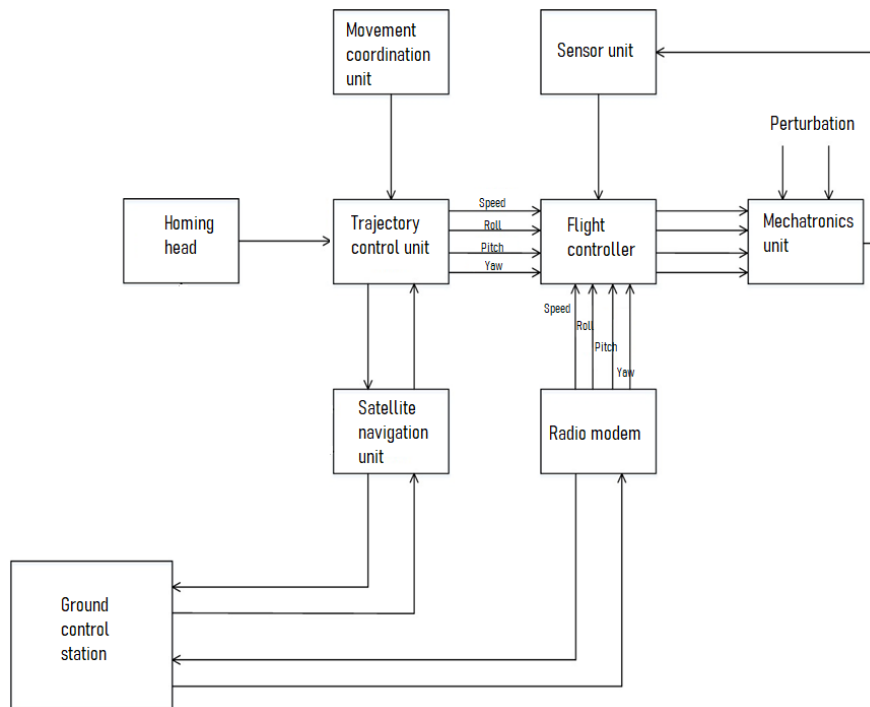

Fig. 3.1 Structural diagram of the UAV CS

<i>ACIC DEPARTMENT</i>				<i>NAU 21 0618 000 EN</i>			
<i>Performed</i>	<i>Maksymchuk M. V.</i>			<i>AUTOMATED CONTROL SYSTEM FOR UNMANNED AERIAL VEHICLE</i>	<i>N.</i>	<i>Page</i>	<i>Pages</i>
<i>Supervisor</i>	<i>Tupitsyn M.F.</i>						
<i>Consultant</i>							
<i>S. controller</i>	<i>Tupitsyn M.F.</i>				<i>431 151</i>		
<i>Dep. head</i>	<i>Sineglazov V. M.</i>						

The main element of the UAV is the flight controller - the core of the drone. Its functions include monitoring the status of location and coordination sensors (gyroscope, accelerometer, magnetometer, etc.), determining GPS coordinates and based on these data to control the motors (perform takeoff and landing, stabilization, movement in space), provide regulation and stabilization of the drone in flight and hover mode. The flight controller must be connected to the on-board computer to be able to specify any point of flight or to load the flight task. The received parameters of movement (speed and angles of roll, pitch, yawing) received on an input are compared by the controller with the current arriving from the sensor unit. Based on the obtained results, it performs calculations and generates control signals that are transmitted to the drone mechatronics unit.

The sensor unit contains a 3-axis accelerometer, a 3-axis gyroscope and a 3-axis magnetometer, static pressure sensor (altitude), dynamic pressure sensor (airspeed). The accelerometer is designed to measure acceleration, the gyroscope - angular velocity, and the magnetometer - a magnetic compass, which allows the drone to synchronize the position of the drone in space.

The mechatronics unit of the drone consists of collectorless motors, each of which is connected to a special speed controller (Electric Speed Controller, ESC), and those in turn to the flight controller.

Drone control can be performed in two modes.

1. Autopilot. Autonomous control of the drone is provided by means of the following blocks:

– trajectory control unit - analyzes the current location of the drone in space (based on data from the moving coordination unit and satellite navigation unit), flight speed, compares them with the specified, generates signals with the required motion parameters (speed and angles) and transmits them to the flight controller, this unit also includes a homing head.

– motion coordination unit - contains a number of sensors, such as sonar, barometer, ultrasonic rangefinders, necessary for more accurate orientation of the drone in space and to detect static interference.

– satellite navigation unit - consists of a GPS module, GLONASS and 4G modem. GPS and GLONASS modules are used to determine the coordinates of the drone, and a 4G modem is used to transmit data, such as flight parameters and video, over the Internet.

2. Manual control. It is provided by means of the radio modem which through the antenna from ground control station (namely, the control panel) receives a signal with the set parameters of movement (speed and angles) and transmits them to the flight controller (Fig. 3.3).

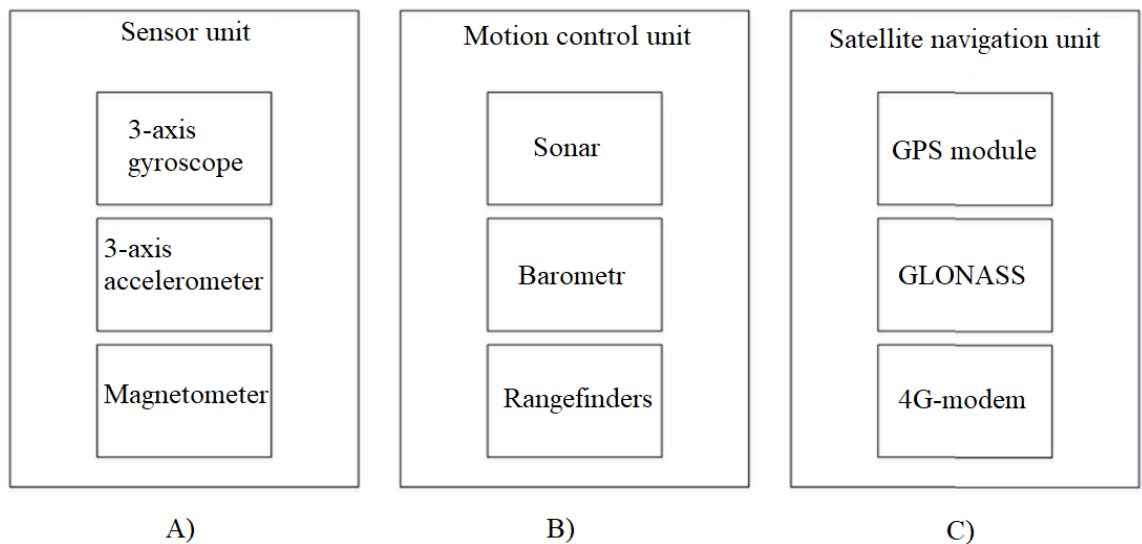

Fig. 3.2 - Components of the units:

A) Sensor unit; B) Movement coordination unit; C) Satellite navigation unit

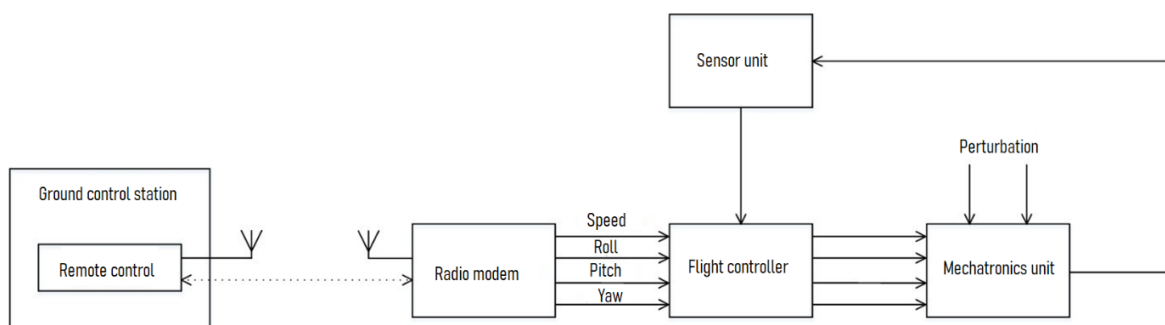

Fig. 3.3 – The scheme of remote-manual control of the UAV

A special role is played by the homing head, it is a set of functionally connected devices: coordinator (which measures the mismatch signal); electronic information processing unit; tracking drive with feedback.

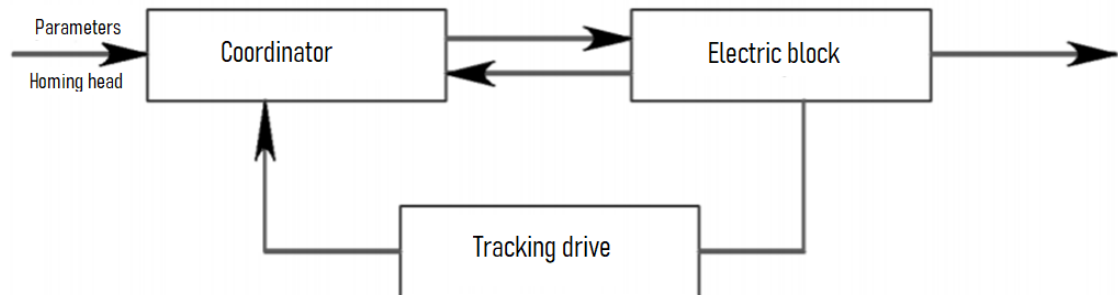

Fig. 3.4 Functional diagram of the homing head

The coordinator is the most sensitive body that accepts the parameters of the object of guidance. It is formed directly from individual interconnected elements, which are used to generate mismatch signals. In its structure, the coordinator can be a very simple and very complex device. It depends on what parameters and with what accuracy are measured. In the General case, the components of the coordinator are the meters of angles, angular velocities, distances, and so on, the computer and the data transmission system.

Types and properties of the output signals of the coordinator depend on the location of its equipment, the type of CS and the degree of its automation. If all the equipment is placed on an UAV, then in the radio CSs of the object of control the output signals of the coordinator are sent to the autopilot.

In this case, the signals from the UAV are transmitted to the control point, where an indicator is installed, which provides visual observation of all guidance objects that are "seen" by the UAV equipment. This type of coordinator connects to a command generating and transmitting device that includes an operator, functional transformations, and an UAV transmission system.

For representation, we describe the structure of the optical coordinator.

The optical coordinator consists of a number of composed elements such as:

- an optical system that collects the radiation flux about the targeting object and focuses it on the sensitive area of the radiation receiver;
- optical filters that attenuate background radiation;
- an analysis device used to analyze the image in the picture plane and determine the coordinates of the image of the guidance object;
- a radiation receiver that converts the energy of optical radiation into an electrical signal;
- electrical unit, which contains voltage amplifiers and all kinds of converters;
- the optical system includes a fairing, in addition to the protective function of the oncoming air flow, it reduces the aberration of the spherical mirror;
- a primary mirror that is part of a spherical surface (the reflection coefficient of metals is equal to 0,94...0,98);
- secondary mirror, made flat and located in the head so that its optical axis coincides with the center of the analyzer;
- the corrective lens maintains the spot size of the residual aberrations by the same angle of incidence of the rays relative to the optical axis.

The necessary components of the ground control station complex are a personal computer with Internet access or a 4G modem for autonomous control of the drone and a remote control (either a tablet or a mobile device) for remote control. The personal computer processes video from the drone, recognizes obstacles and other objects of observation, as well as adjusts the flight route.

When piloting an UAV, the communications imposed on the movement of these controlled objects are more diverse. They determine the predetermined orientation of the longitudinal axis or velocity vector relative to the direction of the guided object - the object called the sight line, the specified position of the center of mass of the controlled object relative to the line control point - the object and so on.

In the process of aiming due to the influence of various outrageous actions, the controlled object deviates from the reference trajectory or communication



disorders appear. Violation of each connection is quantified by the CS, and as a result signals are formed that characterize the measured values of the mismatch parameters.

To control an UAV, the information subsystem generates signals characterizing its errors. These signals are called measured mismatch parameters (trajectory signals).

In the general case, control contains various errors and perturbations, which are random functions of time. As a result, aiming an UAV at a target is a complex random process.

When moving a controlled UAV on a fixed trajectory, the CS must control only its movement and compare the obtained parameters of the real trajectory with the software parameters of the reference trajectory.

The non-fixed reference trajectory is significantly affected by the nature of the movement of the guidance object, which can be controlled by devices installed on board the controlled object, control point or any other place connected to the control point by the data transmission system. In this case, the guidance object is understood as the point to which the CO goes.

The pitch radio CS is developed in accordance with the functional control scheme in the longitudinal channel of the UAV. The input action for the radio CS is a set of devices and devices, which are used to form the measured values of the mismatch parameters for the pitch control channel. These values are obtained by measuring and functionally transforming the parameters that characterize the relative motion of the guidance object and the controlled object.

The functional diagram characterizes the transformation of information into constituent elements and is mathematically described by a set of operations that the CS performs on the measured values.

The CS of an UAV consists of separate functional units: information systems that determine the control parameters, as well as measuring the parameters of the UAV (software devices and power steering amplifiers).

In the CS with the help of the information system, the vector of the range parameter or its scalar component changes, in addition it is necessary to know the values of linear acceleration and angular acceleration - accelerometers, roll angle, angular velocity - gyroscopes. The input signals from the sensors are amplified and converted in the control signal generation unit. The output signals as controls are fed to the drives of the steering organs.

3.2 Control laws synthesis for UAV CS

3.2.1 Preliminaries of flight control of CO

The UAVs' dynamics can be modelled using system states: longitude (p_x), latitude (p_y) and altitude (p_z) for position; u , v and w for velocity; roll (γ), pitch (θ) and yaw (ψ) for attitude; w_x , w_y and w_z for angular rate; a_x , a_y and a_z for acceleration; V_a , V_g for air speed and ground speed; α for the attack angle and β for the slide-slip angle, respectively. The control inputs of small fixed-wing UAVs generally include: aileron (δ_a), elevator (δ_e), rudder (δ_r) and throttle (δ_t). Different types of UAVs may have different control surface combinations. To model the UAVs' dynamics can be used the non-linear equation set below (3.1):

$$\begin{aligned} \dot{x} &= f(x, u) \\ x &= [p_x \ p_y \ p_z \ u \ v \ w \ \gamma \ \theta \ \psi \ \omega_x \ \omega_y \ \omega_z]^T \\ u &= [\delta_a \ \delta_e \ \delta_r \ \delta_t]^T \end{aligned} \quad (3.1)$$

where u is a vector of input signals and x is a state vector.

The ultimate objective of flight control is to let the UAV follow a pre-planned 3D trajectory with pre-specified orientations. There are basically two types of controller design approach: the precise model based nonlinear controller design and the in-flight tuning based PID controller design. The first method requires a precise and complete dynamic model, which is usually very expensive to implement. On the other hand, it is estimated that more than 90% of the current working controllers

are PID controllers. Most commercial UAV autopilots use latter cascaded PID controllers for autonomous flight control.

The cascaded PID controller can be used for UAV flight control because non-linear dynamic models can be linear around certain trimming points and be treated as simple single-input and single-output (SISO) or multiple-input and multiple-output (MIMO) linear systems. The UAV dynamics can be decoupled into two modes for low-level control: longitudinal mode and lateral mode. The following formulas for longitudinal mode. An intuitive controller design to use the classic PID controller structure is as follows:

$$C(s) = K_p \left(1 + \frac{K_I}{s} + K_D * s \right) \quad (3.2)$$

All the controller parameters (K_p , K_I , K_D) can be determined by either off-line or on-line controller tuning experiments.

3.2.2. Overall design of the flight trajectory control system

In a typical photography or surveillance scenario, the UAV requires a stable attitude and position control. Therefore, the flight CS, which can be divided into the outer loop and inner loop, as shown in Fig. 3.5, should make the UAV fly stably.

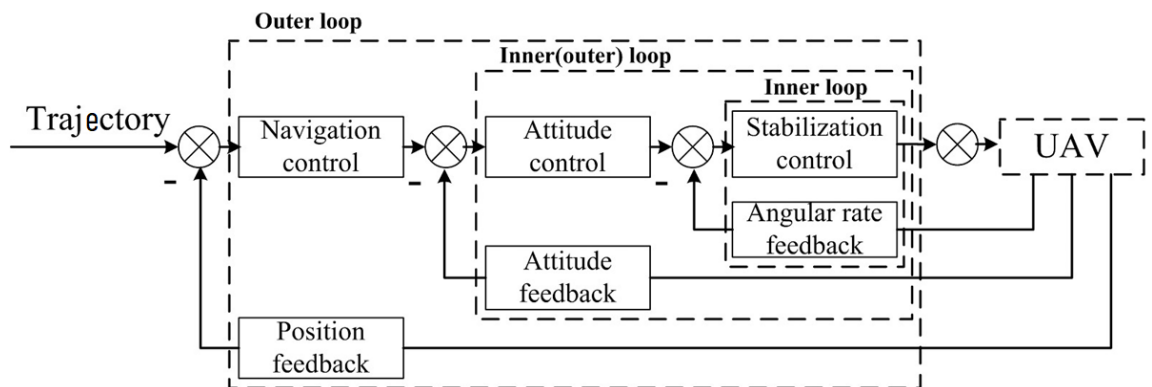

Fig. 3.5 The basic diagram of flight trajectory control

The inner loop is the stabilization and attitude control loop, which is used as the fundamental control loop to guide the aircraft. The stabilization control is used to increase damping and improve UAV stability. Based on the vehicle's

aerodynamics and the sensor information fusion from the accelerometer, gyroscope and Global Positioning System (GPS), the attitude control loop adjusts the elevators and ailerons in real time to correct the roll and pitch angles. The outer loop is a path-following control loop, which acquires heading angle. The navigation loop controls the UAV to eliminate the navigation cross error and heading deviation to complete the tracking task.

3.2.3. Stabilization control

The stability of the UAV under consideration is of medium quality, and longitudinal control and transverse control require damping systems. Increasing damping and automatically maintaining stability is important and necessary for a UAV to provide a stable platform for attitude and navigation control. The damping stabilization loop is the inner ring of the attitude control loop, whose feedback signal is a tri-axial gyroscope output.

Pitch direction represents the angle between the longitudinal axis of the aircraft and the ground. The pitch damper is used to improve the longitudinal direction damping, its input signal is the desired pitch angular rate and the output signal is a percentage of the elevator. The feedback of the pitch damper is the pitch angular rate. In order to simplify the control algorithm, but also to prevent drift error caused by integration, the proportional-derivative (PD) controller can be adopted:

$$\begin{cases} \Delta\delta_e = K_{p_z} e_z + K_{D_z} \dot{e}_z \\ e_z = \omega_z - \omega_{Ez} \end{cases} \quad (3.3)$$

where, ω_{Ez} and ω_z denote the expected and measured pitch direction angular rate, e_z is angular rate difference, $\Delta\delta_e$ is elevator deviator, K_{p_z} and K_{D_z} are the PD control coefficients.

3.2.4 Attitude control



The attitude control is also divided into pitch loop and roll loop. The expectation of the pitch angle and roll angle controller is given by the height and navigation controller, respectively. The following is the attitude control law

The pitch angle controller input signal, the expected pitching angle, is given by the altitude controller; the output signal is a percentage of the elevator. It is the inner control of the altitude control. As the dynamic attitude measurement with a certain error, the PID controller was employed for the pitch angle:

$$\begin{cases} \Delta\delta_e^\theta = K_p^\theta e_\theta + K_I^\theta \tilde{e}_\theta + K_D^\theta \dot{e}_\theta \\ e_\theta = \theta_{des} - \theta_{act} \end{cases} \quad (3.4)$$

where $\Delta\delta_e^\theta$ is elevator percentage, θ_{des} and θ_{act} denote the desired and actual pitch angle, e_θ denotes pitch angle control deviation, K_p^θ , K_I^θ and K_D^θ represent the corresponding proportional, integration and differential control coefficients.

3.2.5 Navigation control

Guidance, navigation, and control algorithms are the core of a UAV flight CS to successfully complete the assigned mission through autonomous flight. The performance of the autopilot for trajectory tracking is an important evaluation. The final objective of the UAV is autonomously to perform search, rescue and surveillance missions. Thus, trajectory tracking capability is very useful to allow the UAV optimally to explore the search area. The navigation control can be divided into longitudinal control and lateral control.

The longitudinal control employs a traditional linear PID algorithm to achieve the desired altitude of the UAV.

$$\Delta\delta_e^h = K_p^h \Delta\theta + K_I^h \Delta\tilde{\theta} + K_D^h \Delta\dot{\theta} + K_p^h \Delta h + K_I^h \Delta\tilde{h} + K_D^h \Delta\dot{h} \quad (3.5)$$

where, $\Delta\delta_e^h$ denotes elevator deflection percentage, Δh denote the difference of current flight altitude and desired flight altitude. The longitudinal control takes

pitch angular, pitch angular rate, altitude difference and altitude difference rate as inputs, and the output is elevator deflection.

3.3 Selection of the controller for the unmanned aerial vehicle control system and its theoretical description

MATLAB and MATLAB Simulink software packages will be used to study the CS and its research. Before synthesizing the CS for the longitudinal motion of the center of mass, it is necessary to calculate the dynamic coefficients. The synthesis of the CS will be carried out using the methods of classical theory of automatic control.

Before proceeding to the implementation of the practical part, it is necessary to analyze the theory of control and choose a regulator for the synthesis of the CS.

Before synthesizing a CS, it is necessary to select a regulator that will create a control effect on the CO.

In our case, a PID controller will be used for synthesis the UAV CS. The main advantage of the PID controller is its ease of setup and fast mode, good accuracy and fast response to disturbances of various kinds. The PID controller is used in inertial systems with relatively low noise levels. At the moment, the use of PID-controller is also relevant, especially in industry, control and stabilization systems. It is also possible to calculate the PID controller in advance by changing its parameters discretely, depending on the dynamics of the CO, such as changing its aerodynamic coefficients for speed and angle of attack, mass change, speed, center of mass location and other UAV parameters in flight.

The control loops make use of standard Proportional-Integral-Derivative (PID) controllers, or in some cases using a subset of these three factors (e.g. A PI, or P controller). The PID controller is a well-established type of controller, frequently used to control a large range of systems. The classic PID controller is a single-input, single-output controller, meaning one output control signal is generated to zero out a single error signa.

The block diagram of classic PID controller has the form:



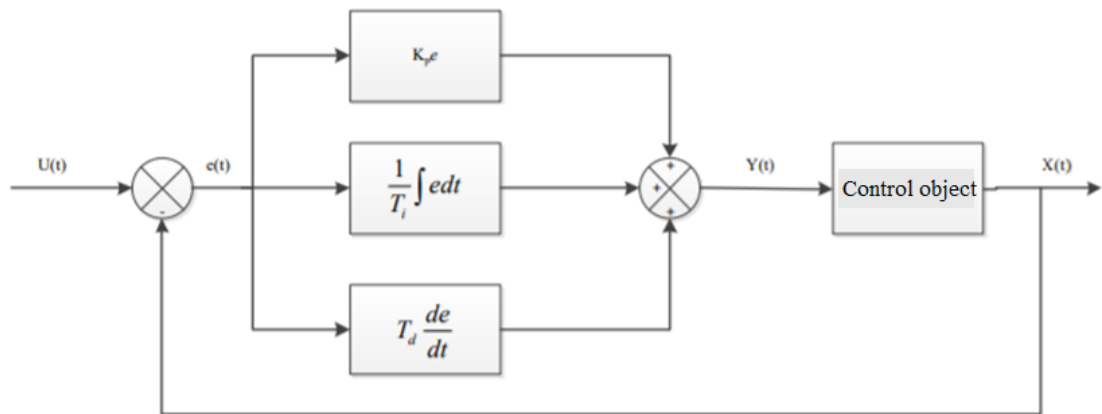

Fig. 3.6 Block diagram of the PID controller

At Fig. 3.6 the following coefficients have the form:

- K_p – gain of the controller
- T_i – integration constant
- T_d – differentiation constant

Many different implementations of the PID controller have been realized, with some presenting certain challenges and requiring adjustments to how certain components are handled. A PID controller can be implemented in the analog world using op-amps and discrete RC elements, or it can be implemented in a digital controller. The general form of the PID controller is:

$$u(t) = K_p + K_i \int e(t)dt + K_d \frac{d}{dt} e(t) \quad (3.6)$$

The general view of the transfer function of the PID controller has the form:

$$K_p + K_i \frac{1}{s} + K_d \frac{s}{Tf s + 1} \quad (3.7)$$

Proportional component of the PID controller P - is responsible for proportional control, the meaning of which is that the output signal of the

controller, counteracts the deviation of the controlled value from the set value. That is, the greater the error of mismatch, the greater the command deviation of the regulator. This is the simplest and most obvious law of control. Its disadvantage is that the regulator never stabilizes at a given value, and increasing the proportionality factor will lead to self-oscillations. That is why it is additionally necessary to introduce an integral and differential component. The proportional error is the instantaneous error value.

Integral component I - integrates the control error, which allows the PID controller to eliminate static error. That is, if the system has an error, the integral component makes a certain shift, thus compensating for the error. However, if the error is small, the effect will be reversed - the integral component will itself make the offset error. The integral error is the integral of the error (The sum of all previous errors).

The differential component D is proportional to the rate of change of the deviation of the adjustable value and is designed to counteract the deviations from the target value that are predicted. The differential component eliminates damped oscillations. Differential control is effective for processes that have long delays. The disadvantage of the differential law is its instability to noise. The derivative is the instantaneous rate of change in the error.

The Ziegler-Nichols method will be used to find the parameters under the controller:

Stage 1: Set the values of the coefficients PID – regulator $K_I = 0, K_d = 0$, and the value of the coefficient K_p , starting with $K_p = 1$, change to that value K_0 , at which the system becomes oscillating and it is possible to allocate approximately 5-7 points of intersection of the schedule of transition process with a constant level.

Stage 2: At $K_p = K_0$ (the system has become oscillating and it is possible to allocate approximately 5-7 points of intersection of the schedule of transition process with a constant level) it is necessary to measure on the schedule of transition process the period of fluctuations of this process. Let this period P_o .

Stage 3: Calculate the rational values of the coefficients PID - regulator (K_I , K_p , K_d):

1. $K_p = 0,6 * K_0$,

2. $K_I = 1,2 * \left(\frac{K_0}{P_0} \right) * \left(\frac{T_0}{2} \right)$,

3. $K_d = (0,075 * K_0 * P_0) / T_0$

The result is the following parameter values: PID controller of the internal circuit: $K_p = 0,0085$; $K_I = 0,00017$; $K_d = 0,06$.

After choosing a controller for the CS and understanding the physical processes that occur in it when selecting and changing the coefficients of each of its components, you can begin to create software for calculating the PID-controller (its coefficients) and study the CS for transient quality and stability of the synthesized system.

The automatic CS has the form (Fig. 3.7):



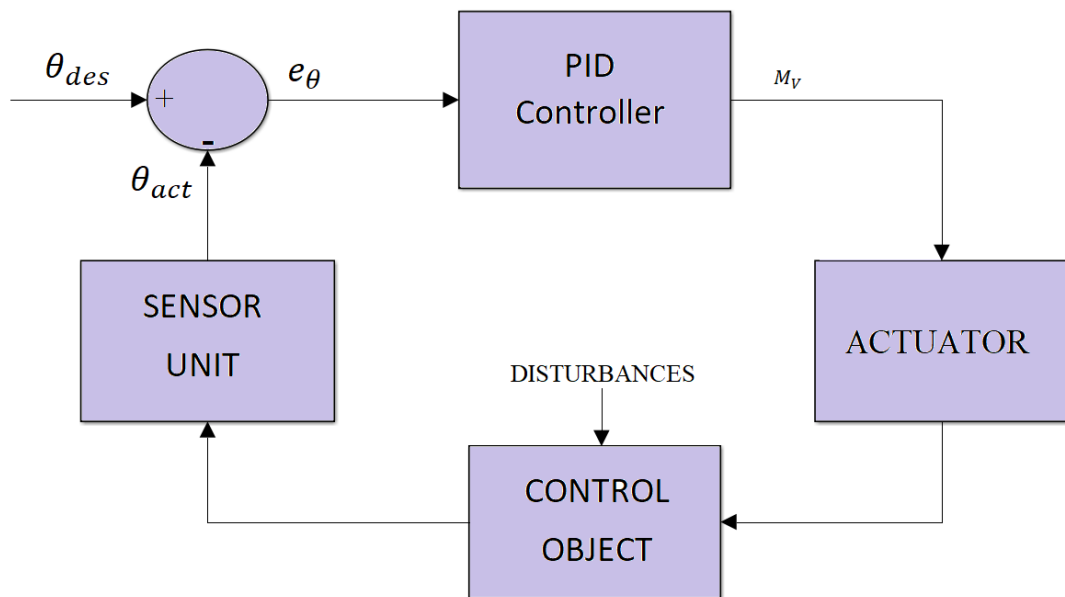

Fig. 3.7 Block diagram of the automated CS

A key element of any ACS is a controller, which is a device that monitors the condition of the investigated CO, in our case the UAV, and provides the necessary control law. The algorithm of the control process includes:

- calculating the error or the mismatch signal difference e_{θ} , as the difference between the desired setting (set point, or θ_{des}) and the current value of the process (process value or θ_{act}).
- setting control signals from the controller to actuator after calculating the error (manipulated value or M_v).
- the actuator affects the CO (in this case the elevator channel), then the UAV reduces the mismatch error e_{θ} due to the deviation of the elevator.
- after that the sensor unit measures the actual pitch angle, then the difference between the measured and the desired value of the pitch angle is fed to the PID controller.

Accordingly, the block diagram of the algorithm of the control system is presented:

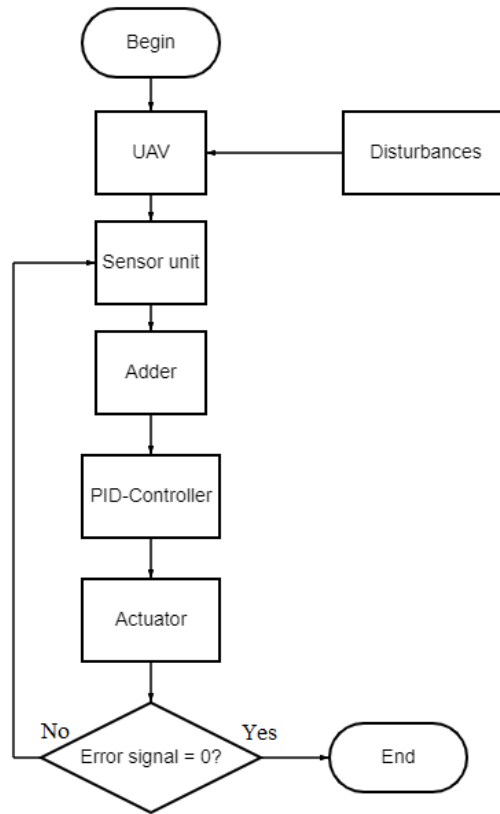

Fig. 3.8 Operational algorithm of the developed control system

For block diagram 3.7, can be written the UAV control law for longitudinal motion:

$$\Delta\delta_e^\theta(t) = K_p^\theta e_\theta + K_I^\theta \int e_\theta(t)dt + K_D^\theta \frac{d}{dt}e_\theta(t) \quad (3.8)$$

$$e_\theta(t) = \theta_{des} - \theta_{act}$$

where $\Delta\delta_e^\theta(t)$ is elevator percentage, $e_\theta(t)$ denotes pitch angle control deviation, K_p^θ , K_I^θ and K_D^θ represent the corresponding proportional, integration and differential control coefficients.

CHAPTER 4. RESEARCH OF CONTROL SYSTEM FOR LONGITUDINAL MOVEMENT OF UNMANNED AERIAL VEHICLE

4.1 Investigation of unmanned aerial vehicle transfer function in MATLAB environment

MATLAB is a programming and modeling environment that allows you to perform the necessary calculations and contains modules that allow you to explore the developed management system for stability and assess the quality of the transition process.

The investigation of the stability of the system is necessary to ensure the attenuation of transients, ie provides a fundamental possibility of the transition of the system from one value to some fixed value in any input interaction.

But in the future it is necessary that the steady state is close to the set, and that the attenuation of the transient process was fast enough, while the fluctuations in the system were relatively small. Therefore, after ensuring the stability of the system it is necessary to ensure the quality of the control process, the concept of which includes:

1. System accuracy in the steady state
2. The quality of the transition process

Input data must be entered before the CS can be evaluated for stability and quality. From the reference books, we obtain the coefficients of the linearized system, which can be represented as a transfer function and then investigate it with a connected PID controller. The input data has the form:

<i>ACIC DEPARTMENT</i>				<i>NAU 21 0618 000 EN</i>			
<i>Performed</i>	<i>Maksymchuk M. V.</i>			<i>AUTOMATED CONTROL SYSTEM FOR UNMANNED AERIAL VEHICLE</i>	<i>N.</i>	<i>Page</i>	<i>Pages</i>
<i>Supervisor</i>	<i>Tupitsyn M.F.</i>						
<i>Consultant</i>							
<i>S. controller</i>	<i>Tupitsyn M.F.</i>						
<i>Dep. head</i>	<i>Sineglazov V. M.</i>						
					<i>431 151</i>		

```

%% вхідні дані
rad = pi/180;
cy_alpha = 0.3224;
cy_delta = 0.0755;
mz_alpha = -0.0772;
mz_delta = -0.0367;
mz_wz = -0.0105;
Iz = 0.1;
m = 5.5;
V = 60;
L_har = 3;
S_har = 0.0705;
R = 5000;
g = 9.81054;
ro = 1.1745;
Q = ro*V*V/2*S_har;

```

Fig. 4.1 Listing of the program with input data for calculation of the CS

In the listing in Fig. 4.1 there is a variable rad, which allows you to transfer the required values into radians, because the aerodynamic characteristics are given in the dimension 1 / deg. Also at the entrance we have aerodynamic coefficients, characteristic dimensions, UAV speed at time, moment of inertia along the Z axis, acceleration of free fall and calculation of velocity pressure multiplied by the area used in the formulas for calculating dynamic coefficients.

Next, to create and calculate the transfer function, it is necessary to enter the previously calculated balancing values of the angles of attack and angles of deviation of the elevator and multiply them by the variable rad in order to convert to radians.

```

alpha_bal = 1.99*rad;
delta_bal = -4.18*rad;

```

Fig. 4.2 Write to the workspace and in the program code the value of the balancing angle of attack and deflection of the elevators

After calculating the balancing values of the angle of attack and the deviation of the elevators, it is necessary to translate all the necessary values into radians:

```

%% mz_wz похідна моменту тангажа по кутовій швидкості
mz_wz = mz_wz/rad;
%% mz_alpha похідна моменту тангажа по куту атаки
mz_alpha = mz_alpha/rad;
%% mz_delta похідна моменту тангажа по куту відхиленню рулів
mz_delta = mz_delta/rad;
%%mz_delta = mz_delta +0
%% cy_alpha Похідна підйомної сили по куту атаки
cy_alpha = cy_alpha/rad;
%% cy_delta Похідна підйомної сили по куту відхиленню рулів
cy_delta = cy_delta/rad;

```

Fig. 4.3 Write aerodynamic coefficients to the workspace

After translating the aerodynamic coefficients in radians, you can proceed to the stage of calculating the dynamic coefficients to calculate the transfer function of the UAV. Dynamic coefficients are calculated by formulas:

```

a1 = -(mz_wz * q_1_iz)           %% mz_wz dynamic
a2 = -mz_alpha * q_1_iz        %% mz_alpha dynamic
a3 = -mz_delta * q_1_iz       %% mz_delta dynamic
a4 = (cy_alpha + R * sin(alpha_bal_deg) / Q) * q_m_v  %% cy_alpha dynamic
a5 = cy_delta * q_m_v         %% cy_delta dynamic

da2 = 0;                       %% dMz_alpha dynamic
da3 = 0;                       %% dMz_delta dynamic

```

Fig. 4.4 Calculation of dynamic coefficients for further calculation of the UAV transfer function

```

a1 =
    5.5442

a2 =
    40.7630

a3 =
    19.3783

a4 =
    2.3677

a5 =
    0.1244

```

Fig. 4.5 Values of calculated dynamic coefficients

The next step is to calculate the transfer function, its time constant, the damping factor and the transfer coefficient:

```
omega_0 = sqrt(a2 + a1 * a4)
T = 1./omega_0
psi = (a1 + a4 + da2) ./ (2.*sqrt(a2 + a1.*a4))
K = -(a2.*a5 - a3.*a4) ./ (a2 + a1.*a4) .* V
```

Fig. 4.6 Calculation of parameters for the transfer function of the UAV

```
omega_0 = 7.3410
psi = 0.5389
T = 0.1362
K = 45.4376
```

Fig. 4.7 The parameters of the UAV transfer function are calculated

Since all the necessary data for the transfer function have been calculated, can be go to the symbolic writing of the transfer function by the Laplace operator (s).

```
s = tf('s');
Tf2 = tf([K], [T^2 2*T*psi 1]);
TfLA_Y = Tf2 * (1/s)*(1/s)
step (TfLA_Y)
hold on
grid on
Tff = TfLA_Y;
```

Fig. 4.8 Writing of the transfer function by the Laplace operator

After software calculation, the transfer function has the form:

```
TfLA_Y =  
  
          45.44  
-----  
0.01856 s^4 + 0.1468 s^3 + s^2  
  
Continuous-time transfer function.
```

Fig. 4.9 UAV transfer function

Figure 4.8 also has a Step command that allows you to track the UAVs response to an abrupt action:

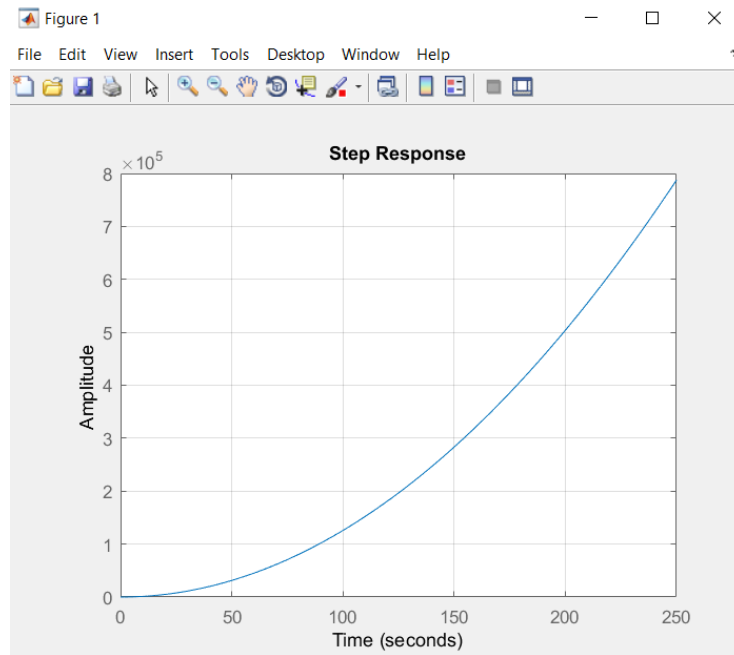

Fig. 4.10 UAV response to the input abrupt action

4.2 Investigation of unmanned aerial vehicle control object in MATLAB and MATLAB Simulink environment

The next step is to proceed to the synthesis of the control object. As mentioned above, an error is applied to the PID controller. Before creating a regulator, it is necessary to make demands on the transition process. The following requirements are set for this type of UAV:

- Transition time $t_{br} \rightarrow \min$
- Overshoot $\sigma \leq 15\%$
- Static error $\varepsilon_{ct} \leq 3\%$

The MATLAB and MATLAB Simulink development environments make it possible to adjust the PID controller both automatically and manually using known coefficient calculation approaches, such as the Ziegler-Nichols method. This method does not work for any system and the results are not the best, but it is very simple and has its place in the basic setting of the controller in most systems. To set the PID controller for the UAV, we will use the built-in functionality of the program MATLAB - PID Tuner, which allows you to get the necessary transient characteristics listed above.

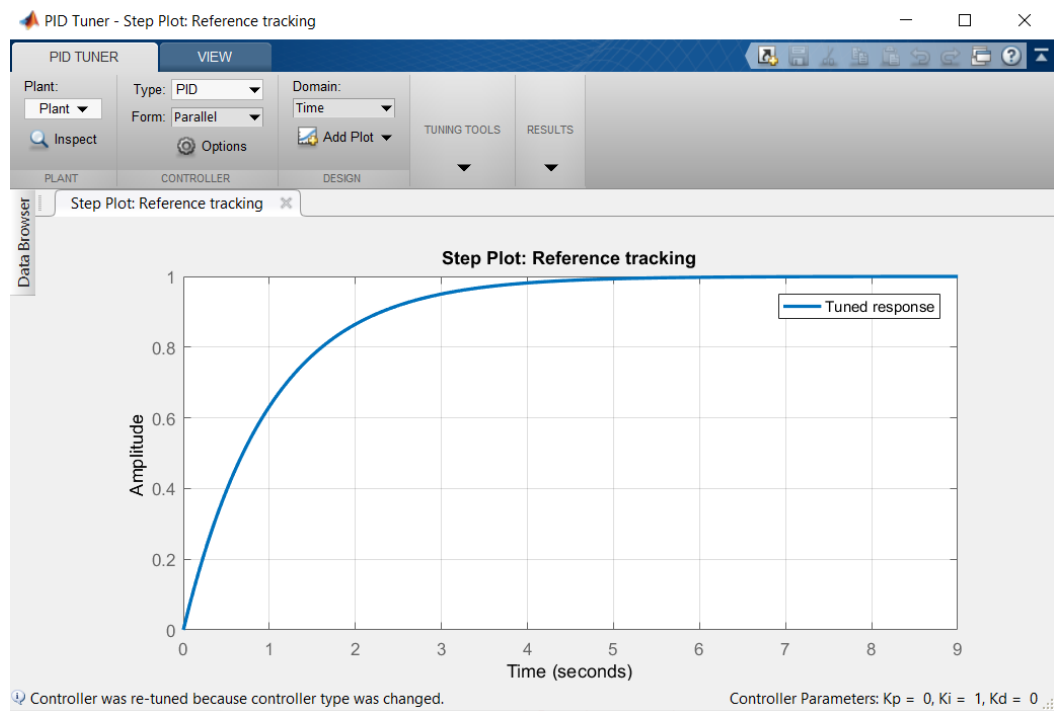

Fig. 4.11 Main window of the program PID Tuner

The PID Tuner program can be called both from the script file and from the command window and in the PID block of the Simulink environment. PID Tuner can be configured both in automatic mode by setting parameters from a script file or command window and in manual mode, calling it as a another program and from the PID block in the Simulink environment.

Parameters for automatic calculation of PID controller coefficients in MATLAB environments are set using the `pidtuneOptions` command. The `pidtuneOptions` command gets several arguments to enter:

- PhaseMargin – the target mark of the margin by phase, ie PID Tuner will try to calculate the controller so that the margin by phase is not less than the specified value. The default value is 60.
- DesignFocus – selects the controller setting for a given phase. The DesignFocus option can take the following values:
 - ‘balanced’ – automatic adjustment of parameters of the controller with a margin on stability and with tracking of performance of the set value

- ‘reference-tracking’ – automatic adjustment of parameters of the controller with exact tracking of performance of the set value
- ‘disturbance-rejection’ – automatic adjustment of parameters of the controller with high resistance to disturbances

In general, for the normal stability of the system, the phase margin, according to the logarithmic frequency criterion of stability should be more than 30° , for greater stability, take the phase margin of 45° or more. In our case, for high stability of the system, the value of the phase margin was accepted 60° .

Set in the MATLAB environment in the script-file to calculate the parameters of the controller parameters for the PID-controller using the command `pidtuneOptions`.

```

%%%%   ПІД регулятор
opt = pidtuneOptions('PhaseMargin', 60, 'DesignFocus','reference-tracking');
%%TfFP = (1/s)
[R, info] = pidtune(Tff, 'PIDF', opt)
TfPID = -R
TFLA = tf(R)*Tff

```

Fig. 4.12 Setting the controller parameters in the environment MATLAB

The obtained transfer functions of the PID controller and the transfer function of the UAV with the controller have the form:

```

TfPID =

      1      s
Kp + Ki * --- + Kd * -----
      s      Tf*s+1

with Kp = -0.00851, Ki = -0.000177, Kd = -0.0601, Tf = 0.00302

Continuous-time PIDF controller in parallel form.

TFLA =

      903.8 s^2 + 127.9 s + 2.658
-----|
0.01856 s^6 + 6.283 s^5 + 49.55 s^4 + 330.7 s^3

Continuous-time transfer function.

```

Fig. 4.13 Transfer function of a UAV with a controller and PID controller coefficients

Having obtained the values of the transfer function and the coefficients of the controller, model shown in Fig. 3.7 in the MATLAB Simulink environment can be constructed. MATLAB Simulink makes it possible to create a circuit with a PID controller and explore its transient and frequency characteristics. Also with the help of MATLAB Simulink it is possible to adjust the PID controller using manual adjustment. For example and for research, a model was compiled into which the values of the UAV transfer function and the values of the controller coefficients were imported from workspace, which were calculated by automatically adjusting the parameters of the PID Tuner program. Block diagram with a PID controller was created in the Simulink environment. Block diagram with automatically adjusted PID controller:

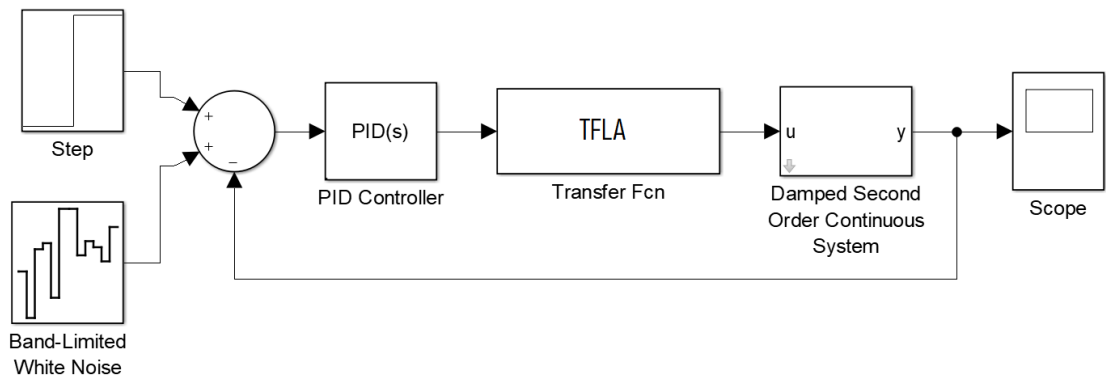

Fig. 4.14 Block diagram of a system with a regulator in the environment Simulink

The block diagram consists of elements of the transfer function which are written in the working space of the MATLAB program, PID blocks, for manual adjustment of the PID controller, the White Noise block, for imitation of input noise, adders, for creation of negative feedback, Scope blocks, for displaying transient graphs on the screen, TFLA - transfer function of a UAV with a regulator, a damping system with a pre-calculated damping factor = 0.5389.

The transient with a controller that is calculated automatically using the PID Tuner settings has the form:

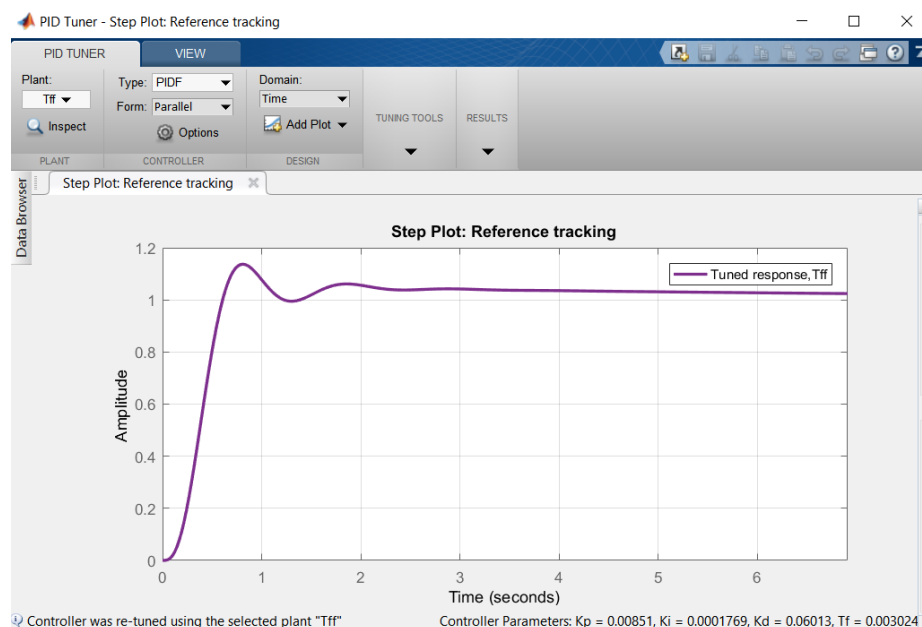

Fig. 4.15 Transition with PID controller calculated automatically

As can be seen from fig. 4.15, the transition process meets the requirements that were set for it. This transition was built using the PID Tuner program, using data calculated in the MATLAB environment..

Settling time is 8.34 seconds, but the graph shows that the system becomes stable after 3 seconds. Overshoot σ - 13.7%. The static error ϵ_{st} is approximately 2%. From all the above we can conclude that the quality of the transition process is part of the requirements that were presented to him.

Table 4.1

PID parameters of the controller and its characteristics

Kp	Ki	Kd	Tf		
0.0085104	0.0001769	0.06013	0.00302		
Rise time	Settling time	Over-shoot	Peak	Gain margin	Phase margin
0.361 sec.	8.34 sec.	13.7%	1.14	8.85 dB	60 deg

To do this, we use the built-in functionality of MATLAB, namely the commands margin and bode, which build LAFC and AFC and display the phase margin and amplitude of the system.



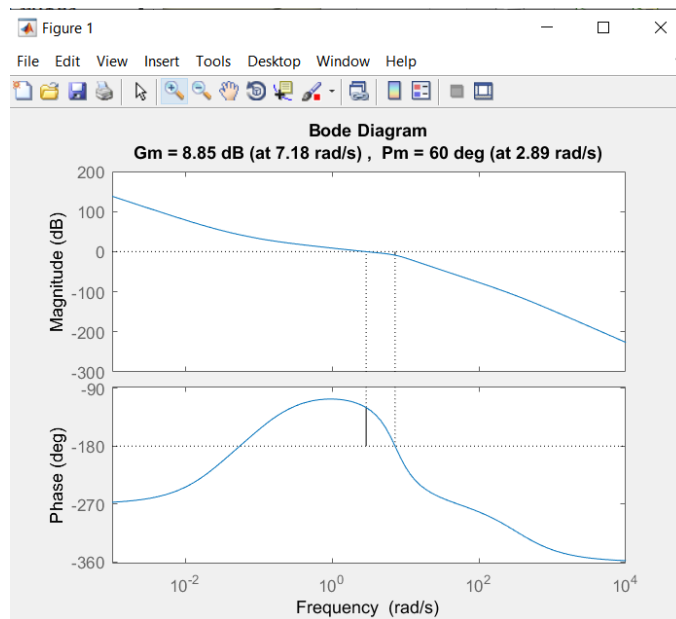

Fig. 4.16 Logarithmic amplitude and phase frequency characteristic

From Figure 4.16 it can be seen that the system is stable, because the open system does not reach -180° at the cutoff frequency. Phase margin and amplitude margin can also be determined from this graph, either by using the margin command in the MATLAB command window, or by writing the command to a script file. The margin for amplitude is 8.85 dB, and the margin for phase 60 degrees, as specified in the parameters for automatic adjustment of the controller program PID Tuner.

But as can be seen from the transient graph (Fig. 4.15), it is possible to achieve a better result by reducing the static error, which is set at about 2%, and reduce the transient time, as the transient time should be minimal. It is also necessary to monitor the stability of the system, as this can lead to undesirable results under the influence of external disturbances, etc.

Since the transient time $t_{tr} \rightarrow \min$ should be reduced if possible, this can be achieved by increasing the value of K_d , as the differential link increases the system speed. It is also necessary to increase the coefficient of the integral component K_I , to reduce static error, but it is necessary to do it gradually, because the increase of the integral component affects the oscillations in the system.

Based on all of the above, we can conclude that the system meets all the requirements that were presented to it. The UAV remains stable and meets the requirements of the control system. The transient process in height is characterized by small oscillations, has a small overshoot and has a static error of 2%, under the influence of external perturbations coming to the system input. That is, such a system can be used for real aircraft / UAVs and it will perform its task of stabilizing the UAV in the longitudinal control channel.



CONCLUSIONS

Graduate work is devoted to the creation of a model of an automated control system for an unmanned aerial vehicle. The following tasks were performed in the work: design features were determined, the purpose and technical requirements to the control system were formulated. The finishing model is designed in the MATLAB Simulink software package.

To achieve this purpose, the following tasks were solved:

- a review of the subject area;
- the structural scheme of the UAV control system is developed;
- a mathematical model of the UAV control system is derived;
- modeling of UAV control system based on mathematical model in graphical environment MATLAB / Simulink;
- the PID coefficients of the controller will be calculated based on the Ziegler-Nichols method;
- the synthesis of the pitch control system of the UAV with the PID controller was performed.

The PID controller is used in the work to solve the problem of aircraft flight control along a given trajectory. The coefficients that meet the requirements of the automatic control system are obtained. Errors of values on pitch angles are given to an input of the regulator, and on an exit values of angles according to which control bodies are rejected are received. The traditional method of providing this mode of operation is to use feedback to generate an error signal between the input and output signals. The calculated error signal is processed by the controller, which on this basis generates a control signal coming to the CO. The controller must generate a control signal so as to reduce the error signal between the input and output error signals to zero..

From the received graphs it is possible to see that the transient process is steady, and the autopilot is capable to cope with the set task of control and stabilization of the UAV on the set trajectory of any kind. The synthesized control system uses a PID



controller that provides a transient time of 3 seconds, overregulation - 13.7%, phase margin - 60° , margin amplitude - 8.85. In the future, more complex control algorithms can be built on the basis of the existing control system.



REFERENCES

1. Unmanned Aviation. *Home*.
URL: <https://www.icao.int/safety/ua/Pages/default.aspx>.
2. Доставка дронами: привіт із майбутнього? – Lemarbet. *Lemarbet / Створення та розвиток інтернет-магазинів*.
URL: <https://lemarbet.com/ua/razvitie-internet-magazina/dostavka-dronami/> .
3. Типы беспилотных летательных аппаратов. Обзор. *Авиатест*.
URL: <https://aviatest.aero/articles/typy-bespilotnykh-letatelnykh-apparatov-obzor/> .
4. Classification of the Unmanned Aerial Systems | GEOG 892: Unmanned Aerial Systems. *Welcome! / John A. Dutton e-Education Institute*.
5. URL: <https://www.e-education.psu.edu/geog892/node/5> .
6. Панов А. С. Система стабилизации БЛА Квадрокоптера / А. С. Панов, С. П. Чашников. // ФГБОУ «МГТУ им. Н.Э.Баумана». – 2012. – №8.
7. Управление квадрокоптером AR.Drone при движении по заданной траектории / [С. А. Белоконь, Ю. Н. Золотухин, К. Ю. Котов та ін.] // Труды XIV Международной конференции Проблемы управления и моделирования в сложных системах / [С. А. Белоконь, Ю. Н. Золотухин, К. Ю. Котов та ін.]. – Самара: Самарский научный центр РАН, 2012. – С. 506–514.
8. Бесекерский В. А. Теория систем автоматического управления / В. А. Бесекерский, Е. П. Попов., 2003. – 752 с.
9. Теория автоматического управления / [В. Н. Брюханов, М. Г. Косов, С. П. Протопопов та ін.], 2000. – 268 с. – (Высшая школа).
10. Воронов А. А. Основы теории автоматического регулирования и управления. Учеб. Пособие для вузов. / А. А. Воронов, В. Н. Титов, Б. Н. Новогранов., 1977. – 519 с. – (Высшая школа).
11. Zuo Z. Trajectory tracking control design with command-filtered compensation for a quadrotor / Z. Zuo. // IET Control Theory Appl. – 2010. – №4. – С. 2343–2355.

12. Безпілотний авіаційний комплекс МП-1 Spectator. *Ukrainian Military Pages*. URL: <https://www.ukrmilitary.com/2016/05/bpak-mp-1--spectator.html> .

13. Синєглазов В. М., Філяшкін М. К. Автоматизовані системи управління повітряних суден. –К.: Изд-во НАУ, 2003. – 502 с

14. Лебедев А. А., Чернобровкин Л. С. Динамика полета беспилотных летательных аппаратов. – М.: Машиностроение, 1973, 548 с

15. Лебедев А. А., Чернобровкин Л. С. Динамика полета беспилотных летательных аппаратов. – М.: Машиностроение, 1973, 469-470 с

16. Лебедев А. А., Чернобровкин Л. С. Динамика полета беспилотных летательных аппаратов. – М.: Машиностроение, 1973, 485-487 с

17. Лебедев А. А., Чернобровкин Л. С. Динамика полета беспилотных летательных аппаратов. – М.: Машиностроение, 1973, 487-488 с

18. Лебедев А. А., Чернобровкин Л. С. Динамика полета беспилотных летательных аппаратов. – М.: Машиностроение, 1973, 531-539 с

19. Лазарев Ж. "Модельювання процесів і систем в MATLAB. Навчальний курс, Пітер (ВХV, 2005), (ru) -512с.

20. Система моделирования динамических систем Simulink. MatLab. *Боровское исследовательское учреждение*. URL: <http://bourabai.kz/cm/simulink.htm> .

APPENDIX A

Tables of aerodynamic characteristics of UAVs

Швидкість - (M)	C _x	C _{y_alpha}	C _{y_delta}	Mz_alpha	Mz_delta	
0.4	0.3501	0.2738	0.0585	-0.0571	-0.0252	
0.6	0.3539	0.2501	0.0518	-0.0589	-0.0264	
0.8	0.3199	0.2814	0.0583	-0.0647	-0.0292	
0.99	0.4149	0.3224	0.0755	-0.0772	-0.0367	
1.4	0.6149	0.2596	0.0491	-0.0605	-0.0258	
2.6	0.4861	0.2195	0.0361	-0.0451	-0.0161	
	C _x					
Швидкість - (M)	Кут атаки - (град)					
0	0	3	5	7	9	11
0.4	0.2907	0.3314	0.4047	0.5142	0.6601	0.8426
0.6	0.3188	0.3615	0.4378	0.5519	0.7032	0.8939
0.8	0.4267	0.4726	0.5547	0.6789	0.8421	1.0469
0.99	0.7404	0.7957	0.8971	1.0475	1.2484	1.4987
1.4	0.9721	1.0145	1.0952	1.2118	1.3687	1.5645
1.5	0.9742	1.0158	1.0933	1.2066	1.3586	1.5486
2.6	0.9307	0.9731	1.0206	1.1069	1.2222	1.3657
	C _y					
Швидкість - (M)	Кут атаки - (град)					
0	0	3	5	7	9	11
0.4	0	0.7832	1.3067	1.8294	2.3518	2.8747
0.6	0	0.8173	1.3611	1.9056	2.4503	2.9898
0.8	0	0.8824	1.4689	2.0564	2.6442	3.2324
0.99	0	1.0796	1.8056	2.5137	3.2354	3.9497
1.4	0	0.8425	1.4035	1.9649	2.5253	3.0875
1.5	0	0.8165	1.3609	1.9052	2.4488	2.9947
2.6	0	0.6178	1.0297	1.4416	1.8531	2.2646
	M _z					

Швидкість - (М)	Кут атаки - (град)					
	0	3	5	7	9	11
0	0	-0.1197	-0.1995	-0.2788	-0.3592	-0.4392
0.4	0	-0.1292	-0.2154	-0.3013	-0.3876	-0.4738
0.6	0	-0.1488	-0.2477	-0.3457	-0.4458	-0.5449
0.99	0	-0.2123	-0.3536	-0.4949	-0.6365	-0.7779
1.4	0	-0.1372	-0.2281	-0.3193	-0.4106	-0.5023
1.5	0	-0.1281	-0.2128	-0.2979	-0.3831	-0.4781
2.6	0	-0.1948	-0.3238	-0.4674	-0.5981	-0.7188

