

MINISTRY OF EDUCATION AND SCIENCE OF UKRAINE
NATIONAL AVIATION UNIVERSITY
FACULTY OF AIR NAVIGATION, ELECTRONICS, AND
TELECOMMUNICATIONS
DEPARTMENT OF AVIONICS

APPROVED
Head of department
_____S.V. Pavlova
'____', _____2022

GRADUATION WORK

(EXPLANATORY NOTES)

FOR THE DEGREE OF BACHELOR
SPECIALTY 173 'AVIONICS'

Theme: 'Impact of reliability parameters on residual life of avionics'

Done by:	_____	K.V. Froyuk
	(signature)	
Supervisor:	_____	O.V.Kozhokhina
	(signature)	
Standard controller:	_____	V.V. Levkivskyi
	(signature)	

Kyiv 2022

МІНІСТЕРСТВО ОСВІТИ І АУКИ УКРАЇНИ
НАЦІОНАЛЬНИЙ АВІАЦІЙНИЙ УНІВЕРСИТЕТ
ФАКУЛЬТЕТ АЕРОНАВІГАЦІЇ, ЕЛЕКТРОНІКИ ТА
ТЕЛЕКОМУНІКАЦІЙ
КАФЕДРА АВІОНІКИ

ДОПУСТИТИ ДО ЗАХИСТУ

Завідувач випускової кафедри

_____ С.В. Павлова

«___» _____ 2022

ДИПЛОМНА РОБОТА
(ПОЯСНЮВАЛЬНА ЗАПИСКА)
ВИПУСКНИКА ОСВІТНЬОГО СТУПЕНЯ
БАКАЛАВР ЗА СПЕЦІАЛЬНІСТЮ 173
«АВІОНІКА»

Тема: «Вплив параметрів надійності на залишкові ресурси авіоніки»

Виконавець:

(підпис)

К.В. Фроюк

Керівник:

(підпис)

О.В. Кожохіна

Нормоконтролер:

(підпис)

В.В. Левківський

Київ 2022

NATIONAL AVIATION UNIVERSITY

Faculty of Air Navigation, Electronics and Telecommunications

Department of avionics

Specialty 173 'Avionics'

APPROVED

Head of department

_____S.V. Pavlova

' ____ ' _____ 2022

TASK for execution graduation work

K.V. Froyuk

1. Theme: 'Impact of reliability parameters on residual life of avionics', approved by order №261/CT of the Rector of the National Aviation University of 05 April 2022.
2. Duration of which is from 16.05.2022 to 19.06.2022.
3. Input data of graduation work: introduction of an improved methodology for estimating failure parameters for residual resources of avionics components.
4. Content of explanatory notes: an analytical review of literature sources from
5. Graduation work topics, content, list of symbols, abbreviations, introduction; 1) Features of the operation of avionics in Ukraine; 2) Choice of reliability model for calculations of residual components of avionics; 3) Initial data and program for calculating the dependence of average residual resources on the average operating time of blocks to failure; 4) Practical recommendations and suggestions for improving the methodology for studying the impact of avionics failure parameters.
6. The list of mandatory graphic material: figures, charts, graphs.

7. Planned schedule

No	Task	Duration	Signature of supervisor
1.	Validate the rationale of graduation work theme	18.05.2022	
2.	Carry out a literature review	19.05-24.05	
3.	Develop the first chapter of diploma	25.05-30.05	
4.	Develop the second chapter of diploma	31.05-04.06	
5.	Develop the third chapter of diploma	05.06-10.06	
6.	Develop the fourth chapter of diploma	11.06-15.06	
7.	Tested for anti-plagiarism and obtaining a review of the diploma	16.06-19.06	

8. Date of assignment: '13' May 2022

Supervisor

(signature)

O.V.Kozhokhina

(surname, name, patronymic)

The task took to perform

(signature)

K.V. Froyuk

(surname, name, patronymic)

ABSTRACT

The explanatory notes to the graduate work 'Impact of reliability parameters on residual life of avionics' contained __ pages, __ drawings, __ tables, __ flow-charts, ___ information source.

Keywords: AIRCRAFT, AVIONICS, RESIDUAL RESOURCES, CAUSES OF ELEMENT FAILURES, RELIABILITY

The purpose of the graduate work is to develop a methodology for research the impact of reliability parameters on the residual resources of avionics components.

The object of the research is the process of impact of reliability parameters on the residual life of avionics and its components.

The subject of the research is the reliability parameters on the residual life of avionics.

Research Methods – reliability theory, statistics theory and analytical analysis.

The scientific novelty of the research - by conducting a study of the reliability parameters of avionics components, the residual resources of aircraft components and systems are calculated, which allows for timely maintenance of aircraft.

The importance of the graduate work, conclusions, and recommendations for implementation of the results: offers and recommendations for the introduction of new models, methods and tools to improve the quality of aircraft avionics components. The introduction of methods and tools to improve the quality of methods for studying the impact of reliability parameters on the residual resources of the components of avionics diagnostics contributes to achieving a high level of flight safety and improving the electrical systems of the aircraft.

CONTENT

LIST OF SYMBOLS, ABBREVIATIONS AND TERMS

ABSTRACT

INTRODUCTION

CHAPTER 1. FEATURES OF MODERN AVIONICS

- 1.1. Introduction to modern avionics.
- 1.2. Operating conditions and reliability of avionics.
- 1.3. Maintenance methods.

CHAPTER 2. THE CONCEPT OF THE RELIABILITY OF AVIONICS

- 2.1. The general concept of the reliability of avionics.
- 2.2. Flight safety

CHAPTER 3. THEORETICAL SUBSTANTIATION OF CALCULATIONS OF DEPENDENCE OF THE AVERAGE RESIDUAL RESOURCES OF AVIONIC COMPONENTS

- 3.1. Initial data and calculation program dependence of average residual resources on average operating time blocks to failure.
- 3.2. Initial data and program for calculating the dependence of average residual resources on the coefficient of variation of the average operating time of blocks to failure.

LIST OF SYMBOLS, ABBREVIATIONS, TERMS.

FS - functional system;

MRS – Maintenance and repair system ;

INS - inertial navigation system

ATS - air signal system

ACS - engine control system

IPS - information conversion system

LRU- Line Replacable Unit

Introduction

Relevance of the topic. It is common to say that the science of reliability is a young science, but this does not mean that people were not interested in and engaged in ensuring the reliability of the technology they create. In the 1940s and 1950s, the theory of reliability, as an independent branch of knowledge, became widespread, mainly in aviation, communications systems, and military technology. Regarding the concept of "reliability", the primary term is "quality". The quality of any product is a set of properties and characteristics that ensures its ability to meet the needs of its purpose and reflect its specificity and difference from other products.

Experience in the operation of avionics shows that the assigned indicators of durability (resource and service life) are often underestimated due to significant errors in the methods used to predict reliability. This leads to the premature termination of the intended use of components and systems, and as a consequence - to unjustified material costs for their completion, to reduce the efficiency of aircraft. It should be emphasized that the residual resource in the general case is not equal to the remaining time before reaching the normative term. The same applies to the remaining service life. Therefore, in order to effectively control the operation of aircraft, it is very important to know not only the average resource but also the useful life of the remaining components of avionics used in flight.

In view of the above, the task of predicting the longevity of operated avionics systems is very relevant and practically important.

The purpose of the graduate work is to develop a methodology for research the impact of reliability parameters on the residual resources of avionics components.

The object of the research is the process of impact of reliability parameters on the residual life of avionics and its components.

The subject of the research is the reliability parameters on the residual life of avionics.

Research Methods – reliability theory, statistics theory and analytical analysis.

CHAPTER 1. FEATURES OF MODERN AVIONICS

Aviation and electronics closely related between by itself. Hard imagine modern a plane without an engine, like a plane without electrical appliances.

Electric means provide functioning all units and aircraft systems, navigation, coordination flights and control of all traffic parameters.

Any equipment modern the plane civil aviation guided and controlled by help electronic devices. Takeoff, en-route flight and landing are performed with assistance large quantity different electrical systems. Electronic equipment provides functioning all air transport systems.

The term " avionics " to look like from two of words " aviation " and " electronics " that literally means any electrical equipment that _ used in aviation technique (Fig. 1). However, in aviation literature this term used for designation electric equipment, posted only on board the aircraft.

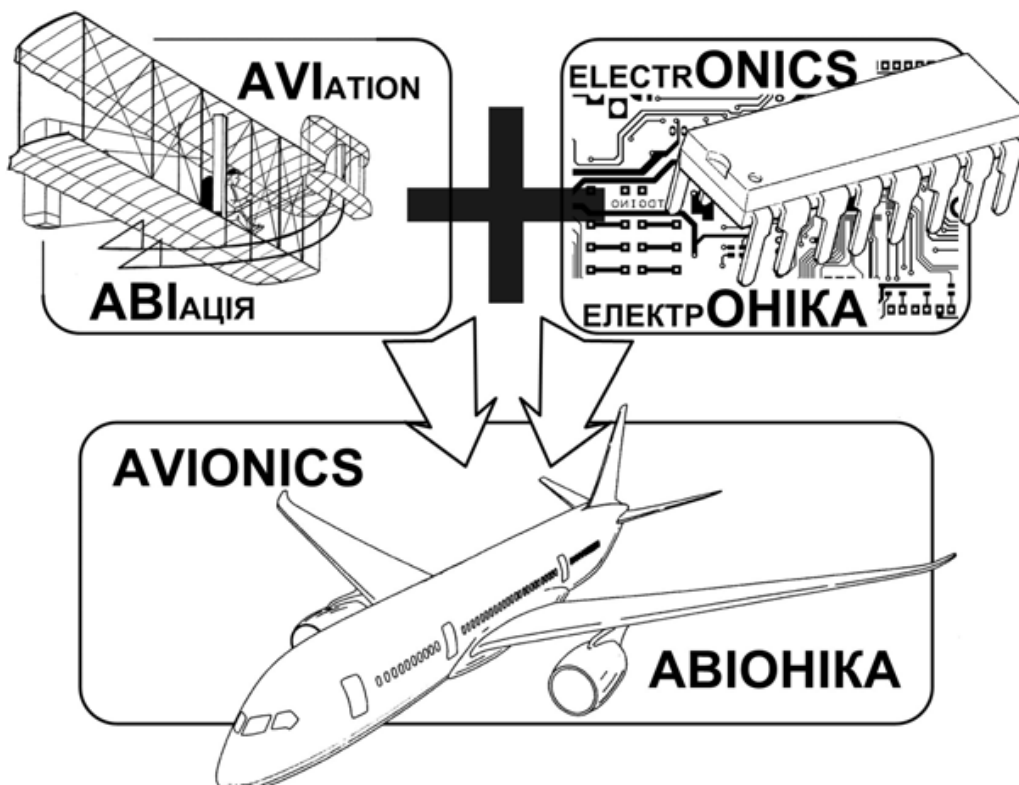

Fig. 1. Term " Avionics "

First term " Avionics " was used in the beginning 1950 in the USA concerning electronic onboard aviation equipment.

In general, at present the term " avionics " has a large number of definitions and applications. Different dictionaries are different him to interpret. For example, overwhelming majority modern electronic dictionaries term " Avionics " is presented as a science and technology that related with electronic systems and devices used in aviation and space _ industry. Yes, interpretation based on that boards electronic equipment space devices has many common with principles of operation of aircraft (PC) systems or are the result of improvement existing PC systems.

One of the main functions equipment avionics is automation processes PC management, in particular software execution of avionics systems all functions required for proper _ implementation safe flight with the smallest quantity member's crew. It encourages relentless _ development and improvement existing onboard PC systems. It is the result of improvement and development existing systems avionics is abbreviation members PC crew up to two persons: commander and first the pilot.

Occurrence and spread in aviation digital lines transmission data and digital techniques allowed significantly reduce the dimensions of each of the block's avionics and expand their functional opportunities. At present system costs avionics make up about 60% of value passenger the plane.

1.1. Introduction to modern avionics

In modern civil aviation, avionics is one of the important factors determining flight safety, efficiency and competitiveness of aircraft.

Today avionics is defined as a complex of onboard electronic equipment of the aircraft, which performs:

1) data collection on:

- environment,
- the state of functional systems ¹that solve the objectives of the flight,
- condition of aircraft engines and aircraft glider design;

2) processing of the collected information by on-board computers;

3) issuance of crew processing results for decision making and / or transmission of control signal directly to actuators (electromechanical, hydraulic), as well as transmission of information to ground services accompanying the flight of the aircraft.

Obtaining data on the environment and the condition of the aircraft is usually carried out using a system of internal and external sensors, recently called the sensor system. External sensors provide information about the position of the aircraft in space and other objects located in this space. Internal sensors provide information on the phase coordinates of aircraft systems, units and mechanisms for the purpose of ensuring equipment control, fault detection, and, if necessary, reconfiguration of the aircraft equipment structure as a whole. The information received in flight from the sensor system is processed by on-board computers to provide the crew and to control the various systems of the aircraft that affect its internal and external conditions. Thus, avionics is used by aircraft crews to control the aircraft and its systems. A simplified scheme of control through avionics is shown in Fig. 2.

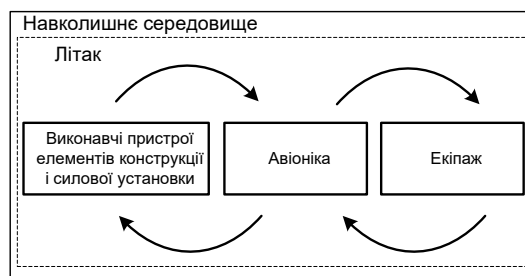

Fig. 2. Aircraft control circuit

The generalized scheme of interaction of components of the complex "crew-on - wind-ship-environment " is given in fig. 3, which shows the information flows of the control loop.

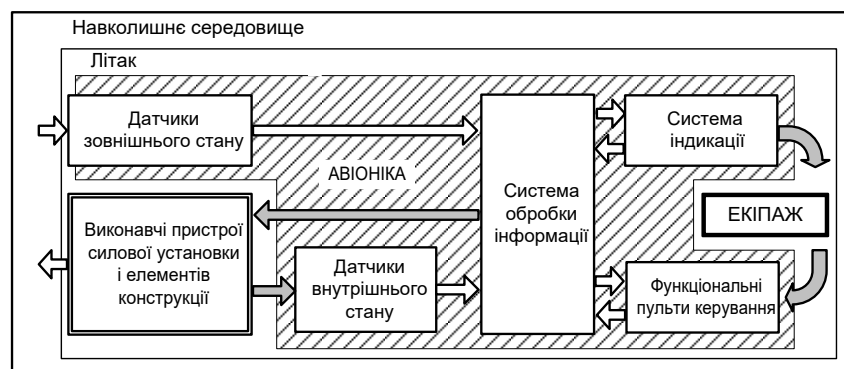

Fig. 3. Generalized scheme of aircraft control

The avionics of modern aircraft is created on the basis of highly integrated systems of on-board electronic equipment (BREO), on-board digital computer systems (on-board computer systems) and on-board information exchange systems (on-board systems).

The most complete idea of the avionics structure of a passenger main plane is shown in Fig. 4., borrowed from, where information links are shown by single arrows →, control - arrows of the type ⇒.

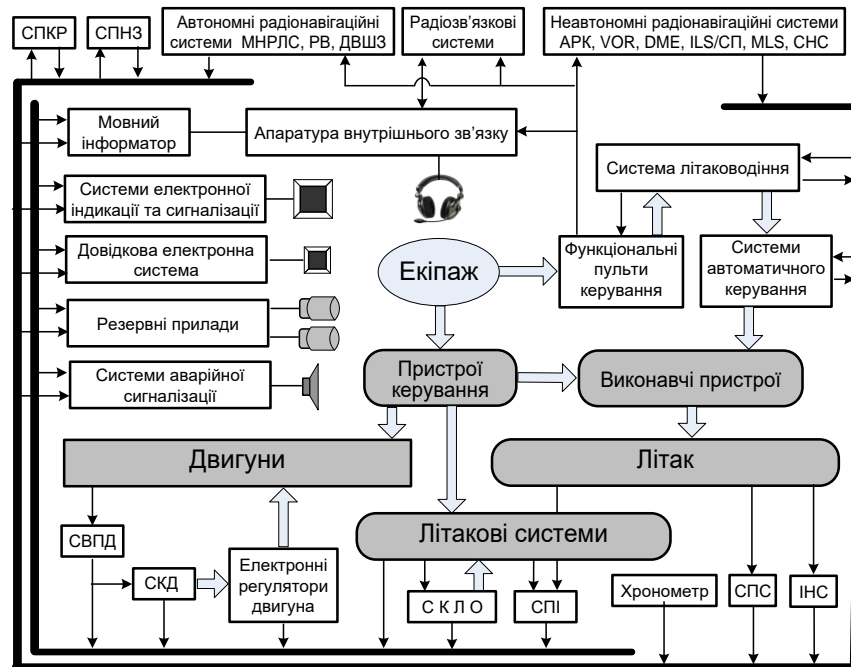

Fig. 4. The avionics of the main / regional aircraft

The control circuit of the aircraft includes *inertial navigation system* (INS) and *air signal system* (ATS), which measure flight parameters and transmit them to the electronic indication and signaling system (SEIS). With this information, the pilot controls the aircraft. There is also an automatic control circuit that includes an aircraft control system and flight and traction control systems. The engine control circuit includes *the engine parameter measurement system* (ADS), which also transmits its information to the SEIS. The pilot monitors the engine parameters on the system indicator. In addition, the aircraft can be equipped with a special computer *engine*

control system (ACS), which performs pre-processing of engine information and signals to the pilot with the same SEIS on the achievement of the parameters of the maximum allowable values. Automatic control of the engine is carried out by electronic regulators of the engine and the screw (if engines are turboprop).

The control circuit of aircraft systems includes *an information conversion system* (IPS), which processes information about the parameters of aircraft systems and transmits them to the indication and alarm system.

The pilot can use the SEIS control panel to display information on the status of all *aircraft systems and devices* :

- power plant;
- fuel system;
- power supply systems;
- hydraulic system;
- pneumatic system;
- oxygen system;
- automatic pressure control systems;
- air conditioning systems;
- control surfaces and wing mechanization;
- hatches, doors.

On modern aircraft, the control of these systems is often automated, for which a special *control system for aircraft equipment* (GLS) is installed.

All radio navigation systems: *non-autonomous* (for example, ARC - automatic radio compass, SNA - satellite navigation system, VOR - radio navigation system, TCAS - air collision warning system, ILS - landing system, etc.) and *autonomous* (eg, MNRLS - meteorological navigation radio station , RV - radio altimeter, etc.) create a complex BREO and, using their antenna -feeder systems, collect *navigation information* . This information, together with the ATP data, INS creates a flow of aeronautical information used by *top-level* systems - autopilot systems, on-board information systems, critical warning system (CRS) and approach warning system (GIS). Moreover, autopilot systems, SPKR and SPNZ replenish this flow of information with their own data.

Another flow of information creates information about aircraft systems and engines. Both information flows to the SEIS, which receives, processes and induces the pilot all the information he needs. As a reserve in case of failure of the main indication / alarm system on board the aircraft, backup electromechanical devices and an alarm system (SAS) are installed, which includes a light signal board in case of dangerous situations.

Modern aviation complexes are territorially distributed within the object (Fig. 5). They implement in real time a set of different functional tasks, which are hierarchically interdependent at the level of the corresponding onboard algorithms and protocols of interaction.

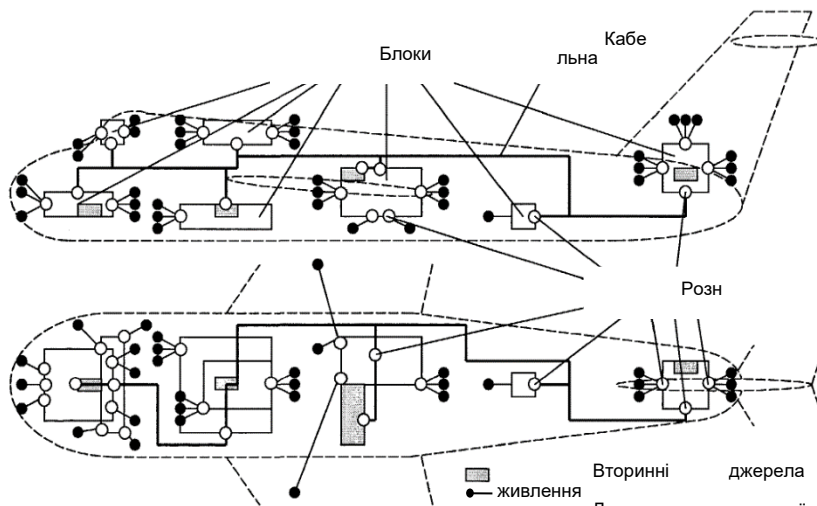

Fig. 5. Placement of equipment on board the aircraft

As a result of territorial distribution and heterogeneity of computing tools used by different developers, there is a need to solve an important systemic problem of their functional integration into a single set of equipment by creating an appropriate on-board information exchange system.

The on-board information exchange system is a set of hardware, software and algorithmic tools required for the organization of data exchange between the various functional components of BREO and BCOS. Some idea of the characteristics of information exchange on board the aircraft is given by the information shown in Fig. 6.

In the development of avionics, there are five generations, which differ in element base, composition, structure and functionality. The avionics of the An-148 aircraft should be attributed to the third generation; it is a set of "black drawers", each of which is an independent hardware and software complex and has its own computer module, operating system and performs a set of functions. This avionics architecture was called *federal* (federated). It is already characterized by the use of different systems of common resources.

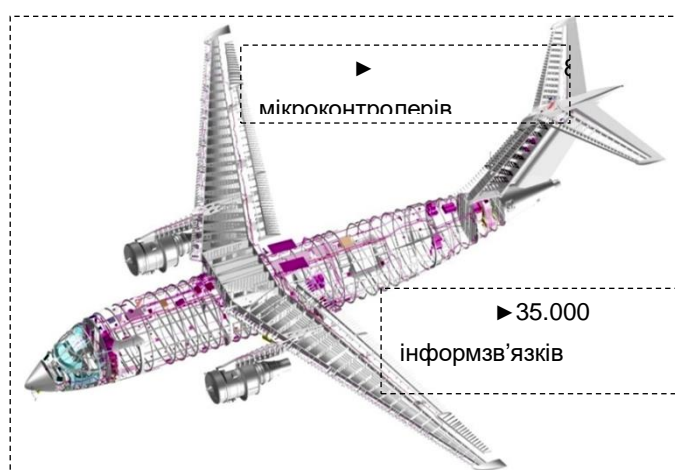

Fig. 6. Digital board of the An-148 aircraft

Subsequent generations of avionics are characterized by the wider use of centralized computing ("open") architecture, and these signs are largely characteristic of the avionics Airbus-380 and Boeing-787. The distribution of information resources for the implementation of various functions is achieved by combining systems into a single multiplex exchange channels. Information generated by one system becomes available to all others and the need to independently collect information that is already in another system is eliminated. In this way, the *sensors are integrated into the sensor system* - they become public, regardless of which system they are installed.

In the architecture of the third and subsequent generations appeared specialized on-board computers (BCM), whose task is only information processing. This is, for example, a computer system for passenger aircraft or a tactical computer for a military aircraft. Such BCOMs receive information from aircraft sensors, process it and pass it on to display and control systems. Due to the pooling of resources, a certain benefit is

provided in terms of weight, size and reliability. Combining devices into a single information system has significantly improved the interface of the crew - aircraft, and the addition of specialized BCOM has increased the level of automation and reduced the load on the crew.

Modern (fourth generation and promising) avionics systems, equipment and individual devices on board the aircraft *are built on a modular (block) principle* and in the process of operation are renewable systems.

The module is a functionally and structurally complete device that implements a certain function or set of functions, dismantled in case of failure and replaced with explicit work capable of maintenance (MA) of aircraft on the parking line

Thus, the module is a typical component of replacement (TKZ) in avionics systems installed on the aircraft.

Typical replacement components in on-board aircraft systems are performed in the form of quick-release modules (SPM) of electronic, computing and electrical systems, as well as in the form of easily dismantled units (LDA) of electromechanical, mechanical and hydraulic systems.

Electronic modules of the avionics system are installed in special boxes - crates; the appearance of the crate avionics shown in Fig. 7. The number of crates in the avionics complex is determined by the complexity of functions and layout requirements.



Fig. 7. Crate modular avionics

Of course, a functional system has two crates, which allows not only to distribute tasks between them, but also to provide redundancy in case of failure. The design of the crate provides mechanical installation in it of the SPM group, contains means for its fixing in the technical compartment of the aircraft, as well as the connection of the

SPM to other avionics equipment. The constructive scheme of the electronic equipment of a crate is shown in fig. 8.

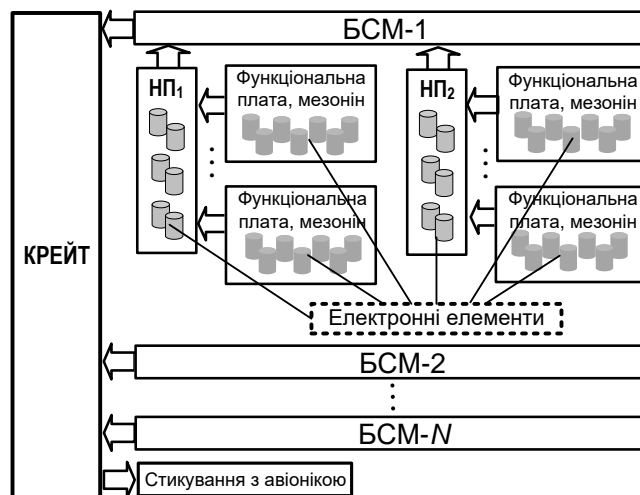

Fig. 8. Constructive scheme of electronic equipment of the crate

The quick-release module is structurally a glass unit that includes printed circuit boards mounted on a solid guide (frame). Quick-change modules can consist of one or more *carrier boards* (NPs) with installed *elements* - chips, resistors, capacitors, fasteners, radiators, sockets, etc. If necessary, structural elements and sockets are mounted on the load-bearing boards for the installation of additional functional expansion boards - *mezzanines*, which allow to increase the computing power of the SPM, expand their functionality, etc. A variant of the module design is shown in Fig. 9.

Most of the computational, indicating, measuring and executive elements of avionics today exist in the form of ready-made families:

- on-board algorithms (subroutines) of complex information processing and control of the vector of the state of the OS in real time;

- quick-change modules, which are unified according to the standards of Euroboards 3U, 6U, 9U (Fig. 10): computer modules (MO), graphics modules (MG), memory modules (MP), I / O modules discrete (MD) and analog information (MA), secondary voltage (MV) power supply modules, radio interference filters (RFPs), etc

∴

- blocks and subsystems of input, control, collection, storage, processing and display of information, on the basis of which the BREO is created .

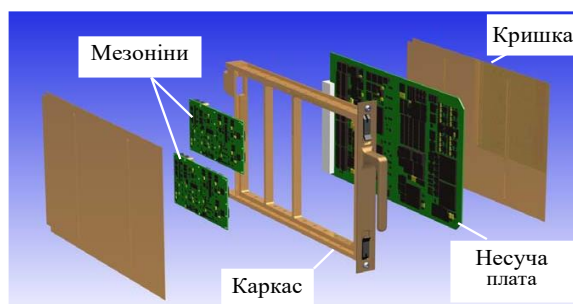

Fig. 9. A variant of the design of the quick-release module

Recent studies of fault -tolerant architecture of onboard equipment, mathematical descriptions of the processes of avionics structures and representation of structures by different mathematical models have revealed a very important feature: all avionics objects of the fourth and probably subsequent generations *have a clear network structure*.

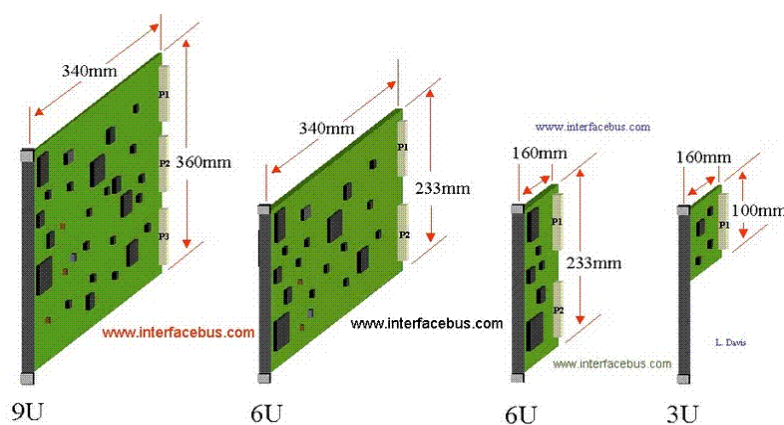

Fig. 10. Standard range of avionics modules

Objects of network structures from rather general positions can be divided into two classes:

- ❖ terminal and
- ❖ transitive.

Depending on the type of system, the terminal objects are:

- in systems of *touch* , *power supply* , *interface* , *display* , *onboard computers* - blocks of electronic equipment;

- in the *software* system - software modules;
- in the *onboard cable network* - sockets that connect the blocks to the cable network.

Transitive objects are:

- in systems of *touch* , *interface* , *display* , *onboard computers* - communication lines providing the corresponding information exchange;
- in the *on-board cable network* and *power supply system* - communication lines that provide the specified electrical parameters.

For the mathematical description of the avionics complex , represented by transitive and terminal objects, it is convenient to use the apparatus of graph theory. A graph is a set of objects called vertices connected to other objects - edges (arcs). Many vertices simulate terminal objects, many edges model transitive objects. As an example we will give graph of the most complex system of avionics - on-board computer, a generalized structural diagram of the physical connections of the blocks which is shown in Fig. 11. and includes:

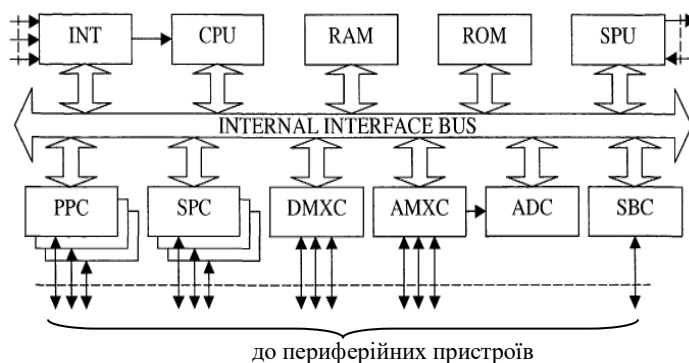

Fig. 11. The structure of the onboard computer

CP11 - CPU, which is used to perform mathematical, logical and other data processing operations.

RAM and ROM - random access and non-volatile storage devices used to store programs, processed data, intermediate results, etc.;

INT - interrupt controller, hardware implementing the process of interrupting the main program on request from an external device and the transition to the execution of the interrupt processing program;

SRU - a specialized processor (so-called accelerator), used to speed up information processing.

In addition, in the on-board computer you can select a group of blocks that hardware-articulate it with other electronic equipment avionics, which include :

RRS - controllers of parallel ports (selector channels);

CPC - controllers of serial ports (selector channels);

DMHS - controller of the parallel multiplex channel;

AMHS - analog multiplexer ;

ADC - analog-to-digital converter ;

SVC is a serial multiplex channel.

Functions of blocks of onboard COM, as a rule, are unified and similar to functions of the corresponding blocks of any another COM.

In the computer all these blocks are digital. Hardware failures of units are reduced to a violation of their performance in all or some modes. In addition, the failures of the hardware of the onboard computer can be attributed to the violation of the integrity of electrical and logical connections between these units.

1.2. Operating conditions and reliability of avionics.

Along with given the physical structural model of the onboard computer is possible its functional model that reflects the functions performed by it and coincides with the model of the algorithms interpreted by it, shown in Fig. 12. Regardless of the type of on-board computer used, its operation is carried out according to some AF algorithm , which means the exact assignment of step -by- step data processing. In the general case, the algorithm includes two major components :

$$AF = \{ G , G_{int} \},$$

where G is a set of basic data processing programs ;

G_{int} - a complex of processing programs interruptions .

Data processing programs are represented by a set

$$G = (A, Z),$$

where $A = \{ a_{1(a)}, \dots, \text{and}_{j(a)}, \dots, \text{and}_{J(a)} \}$ is the set of operators;

$Z = \{ [a_{1(a)}, \text{and}_{j(a)}], \dots, [a_{k(a)}, \text{and}_{l(a)}] \}$ - set of connections between operators.

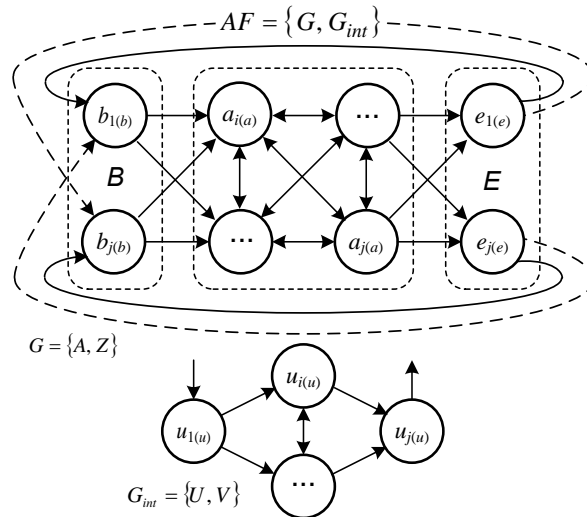

Fig. 12. Functional model of onboard computer

Avionics programs is cyclic - at the end of processing the next data set, coming to the input BCOS , processing of the next array begins.

In parallel with the main software in the onboard computer may have a set of interrupt handling programs

$$G_{int} = \{ U, V \},$$

where $U = \{ u_{1(u)}, \dots, u_{i(u)}, \dots, u_{J(u)} \}$ - the set of operators to which the computational process comes as a result of some external , in relation to the system, influence , called interruption;

$V = \{ [u_{1(u)}, u_{i(u)}], \dots, [u_{j(u)}, u_{J(u)}] \}$ - set of connections between operators U of the algorithm G_{int} .

Algorithm of BCOS operation is one of the main factors determining the information and time characteristics of the onboard computer.

The software operators simulated the vertex of the graph shown in Fig. 12, interpreted sequentially, operator by operator. The model of functioning of the computer in the interpretation of the program is a sequential search of the vertices of

the graph, which in the physical interpretation of the program by hardware is carried out in time (hours, minutes, seconds). The most important characteristics of the processed information (avionics operation) are:

- informative messages (generated by the sensor system, or received at the input of the BCOM , or transmitted via on-board interfaces, presented to the crew , etc.);
- speed of processing and / or transmission of messages.

These characteristics determine the effectiveness of avionics in flight, and in some cases (for example, in force majeure situations) - the efficiency and even viability of the aircraft. Failures in the operation of the computer, which occur due to software errors, lead to misinterpretation of operators, or to the disruption of relations between operators.

However, the violation of structural connections in the software leads, on the one hand, to incorrect (inaccurate) interpretation of data, and on the other hand - to change the values of time intervals during which the onboard computer conducts a survey of peripherals .

The network structure of the avionics complex of a modern aircraft can be visually represented by a graph in the form of a multilevel (hierarchical) network, represented by a subgraph tree , shown in Fig. 13.

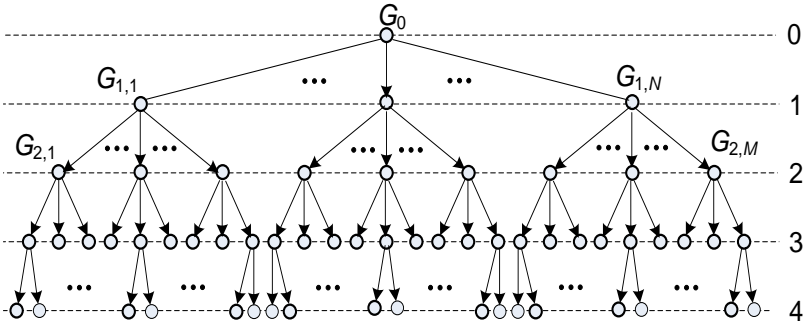

Fig. 13. Hierarchical structure of avionics

The hierarchy is represented by the following levels:

0 - the level of the avionics complex itself , where the subgraph G_0 represents the mathematical similarity of the structure in Fig. 2. and describes the interaction of the systems of the complex (for example, a sensor system that interacts with the power supply system, a computer control system that interacts with the flight control system, etc.);

1 - level of avionics systems , at which each of the subgraphs $G_{1,1} - G_{1,N}$ is a mathematical similarity of structures consisting of interacting subsystems (for example, $G_{1,1}$ - sensor system, which includes a number of sensors that interact through the object, the power subsystem and the information conversion subsystem, installed in the appropriate box);

2 - the level of interacting subsystems, represented by graphs that describe the internal relationships between the components of the subsystems (devices and units, for example, between the processor, random access memory, controllers of peripheral equipment BCOS);

3 - level of interacting components (devices and units, if any), represented by graphs that describe the structure of relationships between component elements, such as logic elements included in the peripheral controller);

4 - the level of interacting elements (chips, transistors, resistors, sensor parts, etc.).

In turn, avionics is part of the aircraft and as an integrated complex of onboard equipment (ICBO) interacts with other complexes, such as a complex of power plants, a complex of weapons, etc.

Graph diagrams describing the structure of avionics have, compared to classical graph diagrams, their specificity, which reflects the fact that the same physical component can be represented in different systems. For example, a software module that implements the data exchange protocol on the interface MIL-STD-1553B, can be represented in the following structures:

- interfaces that provide intermodule exchange on board the aircraft due to the fact that it is part of the interface;
- software due to the fact that the driver of the data transmission equipment, as one of the drivers of the peripheral equipment, is included in the software package of the on-board computer;
- the functional structure of the on-board computer due to the fact that the driver, implemented in the form of a software module, forms a number of algorithmic blocks of the functional structure of the computer that affect the time characteristics of the software;

- the physical structure of the on-board computer due to the fact that the controller of the data transmission equipment is connected to its internal interface;
- power supply systems due to the fact that, as a rule, controllers contain an autonomous secondary power supply unit that is part of the power supply system;
- onboard cable network due to the fact that through the connector is connected to the wires that connect the blocks of the system in the avionics complex .

Distinctive features of modern avionics are:

- multifunctionality, hierarchy, distribution of components of the complex and its network architecture;
- application of more advanced technologies for solving navigation and aerobatic tasks;
- digital processing, transmission and presentation of flight information;
- modular principle of complex construction and transition to crate structures, which provides expansion of hardware integration of functional systems;
- unification of equipment and interconnections on the basis of common international standards;
- application of multilevel automatic control system of the whole complex of equipment, engines and glider;
- miniaturization of the components of the complex on the basis of modern element base;
- increasing fault tolerance on the basis of structural, informational and functional redundancies, reconfiguration of the avionics complex in case of failures;
- reduction of crew loading due to automation of definition / input of flight parameters and availability of multifunctional remote controls;
- introduction of interactive interaction in the system "crew-on wind-ship environment " on the basis of systems of intellectual support of the crew.

The systems of intelligent support of the crew, which operates at all stages of the flight from takeoff to landing and solves the problem of " trajectory " flight safety, include , for example, the following systems:

- system of warning (prevention) of critical modes (SPKR), which is focused primarily on the formation of hints (instructions) to the pilot in special cases of flight,

provided Manual of flight operation, and arise, as a rule, at failures of this or that equipment and technical systems of aircraft. If it is necessary to implement the function of preventing critical modes, the system can replace the pilot in the control loop;

- " intelligent " aerobatic restraint machine, which provides " free " manual piloting of the aircraft by the pilot in the operational area and " soft, unobtrusive " prevention of going beyond it (for example, based on the principle of local-optimal predictive control);

- systems of prevention (prevention) of collision with the earth on the top;

- airborne collision prevention (prevention) system, which builds a three-dimensional map of the location of aircraft in the airspace and forms the parameters of safe flight.

The basic requirements for the structures of avionics and the interaction of its components are set out in a series of documents ARINC-XXX. Thus, a series of documents on digital systems ARINC-700 cover almost all onboard equipment, for example:

- ARINC-701 formulates requirements for the Flight Control Computing System (FASC);

- ARINC-702 - to the Aircraft Computing System (OSL).

- ARINC-704 - to platformless inertial navigation system (BINS).

- ARINC-709 - to the onboard range measuring equipment.

- ARINC-716 - to the transceiver of high-frequency radio communication.

- ARINC-717 - to digital flight data collection and recording devices, etc.

The documents are of a recommendatory nature and are aimed at standardizing the design characteristics of avionics components, input and output electrical signals and their circuits (contacts) in plug sockets, implemented by a system of functions and conditions of their use. Such standardization allows to apply or replace at refusal the systems of the same name of any firm and at any airport. The list of such documents is constantly updated, and the documents themselves are improved.

Thus, avionics is an extremely complex set of onboard equipment that implements the principles of fault -tolerant and fault- tolerant operation in the conditions of real operational factors.

1.3. Maintenance methods.

Any functional, reliable , constructive and technological qualities of the aircraft and its functional systems

laid down in the design,
provided in the manufacture,
confirmed by test results
and are implemented during operation.

To implement in the operation process achieved in the design and manufacture of the level of reliability of the aircraft and its avionics designed maintenance and repair (MA). The current practice of creating new types of aircraft includes the development of maintenance systems directly at the design stage of the aircraft. Thus, the maintenance system selected for a specific aircraft design takes into account all the expected operating conditions of the aircraft of this type.

The main task of the maintenance system is to maintain and restore the airworthiness of aircraft and prepare it for its intended use while ensuring the necessary levels of reliability and readiness for flights with minimal labor and material costs for maintenance. The parameters of the maintenance system (methods of operation, maintenance strategy and their components) are determined by the reliability of the components of the aircraft, and the main task of maintenance is performed with the operating restrictions imposed by the operating conditions.

Operating conditions of the aircraft are characterized by a consistent change in the composition and values of operational factors and can be divided into:

- *estimated* operating conditions, which are defined as a set of factors taken into account in the design, manufacture and testing of avionics;
- *expected* operating conditions, which are defined as a set of factors recognized as acceptable in the operation of avionics and aircraft as a whole;
- *actual* operating conditions, defined as a set of factors acting on aircraft components under operating conditions.

adequacy of the estimated, expected and actual operating conditions ensures *the quality of operation of the product* and characterizes the invariability of those operating in the system of maintenance restrictions. The discrepancy between these conditions leads to a decrease in the quality of operation and efficiency of the maintenance system, up to the impossibility of normal operation and termination of flights (or the impossibility of using avionics for its intended purpose).

This approach is due to the requirements of the Airworthiness Standards of the aircraft, which must be performed in all these operating conditions so that the probability of a special flight situation (complication of flight conditions, dangerous, emergency and catastrophic situations) does not exceed the prescribed value as a result:

- failures and malfunctions ;
- the impact of operating conditions;
- design and functional features of the aircraft;
- errors and violations of the rules of operation.

The real operational factors that affect the reliability of functional systems of aircraft in operation can be divided by the commonality of action into three groups, (Fig. 14.).



Fig. 14. Classification of real operational factors

Here is a brief description of each group of real operational factors.

The group of functional factors determines all types of loads and forces on the elements, components and systems of avionics when using aircraft for their intended purpose, which causes a change in their state and, accordingly, affects the reliability.

The parameters of flight operation of the aircraft determine not only the load capacity of the glider design elements, but also the external loads on the elements of

systems and equipment depending on the flight altitude, speed, mass of the aircraft and other factors.

Modes of operation of products and units determine the levels of their internal structural loads and effects on the elements of products and units in the process of performing a set of avionics set functions to ensure the flight of the aircraft. The modes of operation of products, systems and the entire complex of avionics, as a rule, are functionally related to the parameters of flight operation and flight conditions of the aircraft as a whole.

The actions of the crew in flight determine the differences in the levels of all loads that actually act on the aircraft, products and avionics systems, in relation to such actions in typical operating conditions.

Functional factors are defined continuously, and the scope of their definition has limitations due to flight safety requirements and established directives based on test results. Within the established restrictions, the effect of these factors on specific aircraft of the park is heterogeneous and can vary in level by 3 ... 5 or more times.

The group of regional factors determines all types of non-force external environmental influences on the object of operation and its elements during the service life from the moment of their production to write-off. The level of influence of these factors is determined by environmental parameters, time interval of operation and protective properties of structural elements and products.

The following regional factors have a predominant influence: temperature and humidity; solar activity and insolation; precipitation, their type and amount; strength and composition of the soil; dustiness; salinity of soil and water; biological factors; wind, quantity and composition of chemical impurities in the atmosphere and soil, etc.

The influence of regional factors is manifested in the destruction of paints and protective coatings and the appearance of corrosion foci on the external elements of the aircraft and in leaky volumes. The emergence and development of corrosion is facilitated by the constructive implementation of some areas in modern aircraft. In particular, such zones include:

- underground part of the hermetic fuselage and elements at the joint with it (due to the accumulation of condensate formed during temperature changes);

- area of non-draining fuel residue in the caissons of the wing (due to the accumulation of water in the sludge of fuel);
- battery installation area (due to electrolyte contact) and some others.

Under the influence of functional and regional factors during the operation of aircraft in avionics components damage and malfunctions appear and accumulate, which must be prevented or eliminated by technical factors in the maintenance system.

The resistance of avionics to the influence of external perturbations is confirmed by tests in accordance with the requirements of the regulatory document RTCA / DO-160F(*Environmental Conditions and Test Procedures for Airborne Equipment - Environmental Impact and Airborne Equipment Test Procedures*).

The group of technical factors in its impact on the reliability of functional systems of the aircraft is *one that supports and restores*. Maintenance modes are assigned to:

- ensuring the intended use of the aircraft;
- control of the technical condition of the aircraft;
- maintaining or restoring reliability to the required or specified levels.

All technical factors have directive levels, homogeneous for all aircraft of this type. Homogeneity of levels is provided by application of uniform documentation and technology, qualification of executors and the organization of maintenance . Adjustment of the levels of technical factors is carried out directly, based on the results of research, testing and experience of aircraft operation. Determining the required levels of technical factors due to the requirements of reliability and safety of flights, and is the subject of maintenance optimization . During the period of operation of each type of aircraft, the levels of technical factors may change within acceptable limits by 2 ... 3 or more times.

Complete and objective qualitative and quantitative characteristics of the operating conditions of the aircraft ensures the effective functioning of the maintenance system , a component of which can be considered the *monitoring system of the aircraft*, which carries out:

- continuous monitoring of changes in the state of all electronic, electromechanical, mechanical and other functional systems and individual units of the aircraft, as well as power elements of the glider design throughout the flight;

- accumulation in the on-board operational recorder of the information necessary for ensuring operation first of all of engines, auxiliary power plant and systems of providing landing, and also registration of the additional parametric information necessary at the analysis of not signaled failures;
- interaction with the ACARS system ², transfer of flight information about failures to the ground station;
- providing on-screen displays of information about current failures in systems and equipment, as well as information stored in the on-board drive.

Thus, the system of technical operation and repair is integrated with the avionics complex , maintaining a high level of reliability during flight operation of the aircraft and ensuring flight safety.

CHAPTER 2. THE CONCEPT OF THE RELIABILITY OF AVIONICS

2.1. The general concept of the reliability of avionics.

Reliability - the property of technical systems to maintain working condition for a long time in the set operating modes and in the conditions : - intended use , - maintenance, storage and - transportation.

It is common to say that the science of reliability is a young science, but this does not mean that people were not interested in and engaged in ensuring the reliability of the technology they create. In the 40's and 50's of the last century, the theory of reliability, as an independent branch of knowledge, became widespread mainly in aviation, communications systems and military equipment. The greatest developments related to the development of electronics in the 40s of XX century in radar, were made in England and America. These include the famous SCR -584 anti-aircraft radar, which performed well during World War II, as well as airspace surveillance radars. But the first serial samples of radio systems were so complex, and the impact of elements on the performance of functions is so great that only the clearest and flawless actions of highly qualified service engineering and technical personnel could provide the minimum required level of reliability.

It was then that the US Secretary of Defense stated that maintaining electronic equipment worth \$ 1 costs \$ 2 a year. It became clear that elements and systems should be designed *primarily to work reliably*. As a result, the Minister of Defense, when announcing the tender for the supply of electronic equipment, demanded that equipment developers (designers and technologists) prove the reliability of their equipment based on the results of long-term tests. The results of these tests and formed the first known database of reliability " *Military Standard 217. Reliability prediction of electronic equipment* "- Forecasting the reliability of electronic equipment.

Regarding the concept of "reliability", the primary term is "quality".

The quality of any product is a set of properties and characteristics that ensure its ability to meet the needs in accordance with its purpose and reflect its specificity and difference from other products.

The change in product quality over time can be absolute and relative. *Absolute change in quality* is associated with various internal and external destructive processes that affect the product during operation and change the properties and condition of the materials from which it is made. Due to this, there is a decrease in product quality and its physical degradation (physical aging).

The relative change in product quality is associated with the emergence of new similar products with better performance, in connection with which the indicators of this product become below the average level of all products with a similar purpose, at least their absolute values may not change (aging).

The science of reliability studies only the absolute changes in product quality indicators, ie changes associated with various degradation processes.

Obviously, the design of new equipment without the development of special measures to ensure its reliability loses its meaning. The danger is not only that this sophisticated new technique will not work, but mainly that failure to do so could lead to catastrophic consequences.

The science of reliability produces and systematizes knowledge about maintaining the efficiency of products in the process of their intended use. It has all the features inherent in an independent scientific discipline, namely:

- specific object of research (preservation of serviceability of products);
- fundamental categories and concepts (reliability, reliability, fault tolerance, durability, failure, failure, etc.);
- own research methods (reliability calculation, reliability tests, reliability modeling);
- methods of quantitative measurement of reliability indicators;
- reliability management methods (recovery, reconfiguration of structure, redundancy, etc.).

The stage of application (flight operation) of the aircraft covers, as a rule, a long period of time. Under the influence of various factors there is a change in the level of properties that determine the quality of the components of the onboard equipment (and the aircraft as a whole) and the efficiency of their operation. Therefore, the most

important property of any technical product is *reliability*, which determines its ability to perform the required functions for a long time.

The subject of the science of reliability of technology is the study of patterns of change in quality indicators over time and the development of methods that allow with minimal time and resources to ensure the required duration and efficiency.

The development of the science of reliability is carried out with active interaction with other sciences. Mathematical logic allows the language of mathematics to present complex logical relationships between the states of the system and its components. Probability theory, mathematical statistics provide an opportunity to take into account random in time failures and failures in the object under study. Graph theory, operations research, modeling theory - all these are scientific disciplines, the use of which allows you to successfully solve problems of theory and practice of reliability.

The methodology of ensuring reliability is in a state of continuous development, conditionally divided into several stages. At the first stage, all attention was paid to assessing the reliability of relatively simple products based on information about the reliability of components and test results. Many useful results have been obtained at this stage. The main one is the quantitative assessment of reliability indicators.

Further development of technology has shown that this orientation ceases to meet the needs of practice. With the advent of complex information systems designed on the basis of computer systems, a new task has emerged - managing the formation of values of reliability indicators, rather than just passive registration of the results of calculations and tests. Solving such a problem requires the disclosure of the main factors that affect the reliability and the ability to manage the application of these factors. In the practice of creating aircraft equipment complexes, a comprehensive (systemic) approach is implemented, which provides control of the reliability of on-board equipment components at the earliest stages of design. The integrated approach provides separate and joint study of the impact on the reliability of equipment: hardware, software (software) and the operator, the study of the impact of different architecture options, methods of functional control, restoration, spare part design, testing, etc.

At the same time there is an urgent need to study, create and improve methods for calculating the reliability of systems taking into account not only structural construction but also control, temporary redundancy, hardware failures, software errors and the degree of its development, diagnostic methods, principles of exchange fund and etc., because without them it is not possible to evaluate and, consequently, manage the reliability of the developed systems.

Specific features of reliability issues are:

–*taking into account the time factor*. Reliability is like "quality dynamics", as it examines the quantitative change over time of quality indicators relative to their primary level;

–*prognostic value of results*. Reliability problems are primarily related to predicting the behavior of a product or system in the future, because simply stating the level of reliability of a product that has already developed its resource is of little value. Therefore, one of the most important tasks of the theory of reliability of avionics systems should be considered to predict faults and prevent the possibility of avionics failures during the flight task.

Historically, the science of reliability has developed in two main directions.

The statistical direction emerged in radio electronics, it is associated with the development of mathematical methods for assessing reliability, with the development of methods for statistical processing of reliability information, with the development of structures of systems that provide a high level of reliability. As a theoretical basis in this area were used: probability theory, mathematical statistics, random process theory, queuing theory, mathematical modeling and other sections of mathematics.

The physical direction emerged in mechanical engineering and is associated with the study of failure physics, with the development of methods for calculating the strength, wear resistance, heat resistance. The theoretical basis of this area are the natural sciences, which study various aspects of destruction, aging and changes in material properties: the theory of elasticity, ductility and creep, fatigue strength theory, fracture mechanics, tribology, physicochemical mechanics of materials.

Currently, there is an active process of combining statistical and physical directions, the transfer of rational ideas from one area to another and the formation on

this basis of a single science of reliability of aviation technology. This is largely due to a wide range of different physical factors and phenomena that accompany the flight in the atmosphere, as well as a variety of physical principles used to implement a set of onboard equipment necessary functions.

Thus, reliability is an integral feature of technical products. It is extremely important to ensure the reliability of aircraft and flight safety, a component of which is a complex set of onboard equipment. This requires:

- know the causes and patterns of changes in the physical properties of the elements of aviation electronics (avionics) in the process of long-term operation;
- at the stage of designing on-board equipment (avionics) to ensure the adoption of such engineering decisions that take into account the peculiarities of aircraft and trends in its development.

2.2 . Flight safety

The most pressing problem of modern aviation is to ensure flight safety, which depends on the level of reliability of aircraft. Flight safety is not only an indicator of the effectiveness of the automated technological complex "crew-aircraft" , but also a necessary condition for its operation.

Flight safety can be defined as a property of the crew-aircraft complex, which ensures its ability to fly without an accident in the expected operating conditions.

An aviation accident is defined as an event related to the flight operation of an aircraft and consists of:

- in partial or complete destruction of the aircraft;
- in the death of people as a result of partial or complete destruction of the aircraft.

Aviation accidents also include the loss of an aircraft, its loss as a result of forced landing when evacuation is impossible, regardless of the degree of damage.

In the practice of flight work there are cases when due to various circumstances and reasons there is a violation of the conditions of the flight task, which complicates the flight or makes it dangerous. There are three reasons, or rather three groups of so-called accident factors that pose a threat to flight safety:

1) *dangerous failures of aircraft in flight*, in particular, the language of power plants, control systems, aerobatic, electric power systems, take-off and landing devices, life support systems;

2) *human factor*, which includes errors and gross violations of the crew in piloting the aircraft, errors of flight and engineering staff in preparing aircraft for flight, errors and violations in the organization and management of air traffic, poor performance of technological and renewable work and other factors that are commonly referred to as subjective;

3) *unfavorable flight conditions*: atmospheric turbulence and storm clouds, fogs and sandstorms, icing of the aircraft, collisions with birds and other factors that are considered objective.

As a result of one or more emergency factors in flight, an *emergency situation is created*, ie a situation in which the capabilities and qualifications of the crew, *as well as reserves of aircraft performance may be insufficient to prevent an accident*.

The study and development of methods to prevent the occurrence of the first group of emergency factors that pose a threat to the safety of aircraft and is the direction of the science of avionics reliability, which is considered in the textbook.

Ensuring the reliability of the aircraft as a whole and each functional system separately begins at the earliest stages of design. The resource reserves of the avionics structures should be so high that the occurrence of a catastrophic situation in flight for technical reasons was an event almost unbelievable.

An event that is unlikely to occur on each individual aircraft during its service life, due to the minimum flight time of 60,000-80,000 hours for 25-30 years, is considered to be almost unbelievable. The probability of an emergency in flight due to failures of avionics components is for modern aircraft value $10^{-8} \dots 10^{-9}$.

According to ICAO regulations, the emergence of a complex situation caused by functional failures in flight, it is recommended to consider it as an unlikely event that is unlikely to occur on each aircraft during its service life, but may occur several times if you consider a large number of aircraft of this type.

Permissible probabilities of special situations in flight *for the aircraft as a whole*, which are caused by failures (functional failures of aircraft systems, external influences, errors), are given in table. B1 based on the data of current Aviation Rules.

Table 2.2.1.

Probabilistic characteristics of special flight situations

A special situation	Category events	Probability occurrence (per flight hour)
Catastrophic (catastrophic effect)	Almost unbelievable	$\leq 10^{-7}$
Emergency (emergency effect)	Extremely unlikely	$\leq 10^{-6}$
Complex (significant effect)	Unlikely	$\leq 10^{-4}$

The design of avionics components forms an iterative process in which a *preliminary safety assessment of the system is performed many times* and safety requirements are determined, namely:

levels of guarantee of safe design, determined by the functions implemented in the equipment;

- probabilistic requirements for incorrect performance or loss of function;
- characteristics of architectural and functional security;
- introduction of security measures to ensure the correct operation;
- heterogeneity of means of providing both the assigned function and means of security control;
- preventing the impact of design errors on safety and the use of fault-tolerant structures.

The constant increase in safety requirements has led to the fact that modern on-board electronic equipment systems are fault-tolerant devices with multiple redundancy. At their construction various forms of redundancy are used: structural, informational,

functional which are managed by means of various means of the built-in control and diagnostics. All this provides a significant reduction in the significance of failures, because not only single, but often multiple failures of most components of avionics do not cause catastrophic consequences. At the same time, the total intensity of the failure rate increases in proportion to the amount of equipment installed on board both the main and the amount of what is in the hot reserve. With the introduction of digital computer equipment (DTC) in the onboard equipment complexes, its specific features became apparent. Among the list of on-board failures, the most problematic for monitoring and diagnostics should be considered intermittent failures, also called short-term, hidden, floating, self-retracting or flickering failures. Such failures cause failure of all onboard equipment and can lead to catastrophic situations. Failure is understood as self-correcting disturbances of normal functioning of the onboard equipment due to short-term influences on a certain element (or set of elements) of external and internal factors. After a failure, the equipment can work normally for a long time, but the information may be distorted during transmission or processing operations.

The problem of failures in on-board equipment has recently received increased attention. At the same time, the key problem of cardinal increase in the reliability of equipment containing tens of thousands of potential sources of failure (multi-contact connectors that connect LSI and VLSI devices, printed conductors, communication lines - interface buses, power buses and others), is the diagnosis of failures, directly related to the detection and registration of sources of failures in the equipment.

The second feature of the DTC is the so-called "software failures", which are caused by errors in the developed programs and failures in the hardware environment, are detected during the computational process and lead to functional failures of avionics.

avionics software. In particular, the RTCA has developed (and maintains) requirements for the avionics software design (software) process and the thoroughness of its verification depending on its level of security criticality, set out in the DO-178B standard called *Software Consideration in Airborne Systems and Equipment Certification* (Requirements for onboard equipment software for equipment certification). The European analogue of DO-178B is the standard *ED-12B*, and the

Russian analogue - "Qualification requirements KT-178V", developed by the Interstate Aviation Committee (IAC). Since 2005, a new version of the software certification standard for on-board equipment - DO-178C has been developed.

Problems of providing many flight functions critical to flight safety are also facing the developers of fault -tolerant on-board equipment. These problems arise due to the fact that the performance of many flight functions is more and more subject to the adverse effects of *errors in the design of equipment*, which is difficult to eliminate due to the growing complexity of electronic equipment.

In order to counter this perceived escalation of risk, it has become necessary to provide a more constant and controlled way to eliminate structural errors of the equipment during the design and certification processes. The standard DO-254 - *Design serves this purpose Insurance Guidance for Airborne Electronic Hardware*. The standard was developed and maintained by the *RTCA Association*. The document is designed to help aircraft designers and suppliers of aeronautical electronic equipment ensure that their electronic equipment safely performs the required functions. The document defines the rules for the design of on-board electronic equipment, starting from the concept, then through certification and subsequent certification improvements of products that support airworthiness. The standard helps reduce the likelihood of undetected design errors by using proven technological methods identified in previous developments, and similarly to the DO-178C, establishes five categories of security assurance for the developed hardware, corresponding to five levels of software security. The Russian analogue of this document is the "Guidelines for guaranteeing the design of on-board electronic equipment KT-254".

The DO- and DO-254 guidelines 178Care a consensus of the aviation community and a collection of the best practical industry data to ensure the development of "safe" software and the design of "safe" on-board electronic equipment for high security avionics.

Compliance with the requirements set out in these standards in the design of the avionics complex guarantees the receipt of a certificate from the European (EASA) - *European Aviation Safety Agency* - European Aviation Safety Agency) and American

(*FAA - Federal Aviation Administration* - Federal Aviation Administration) of aviation authorities, which allows the operation of aircraft on international airlines.

Thus, obtaining a certificate is a guarantee of the reliability of avionics, ie sufficient quality of the aircraft's onboard equipment, which ensures its operation without losing critical functions for the flight.

CHAPTER 3. THEORETICAL SUBSTANTIATION OF CALCULATIONS OF DEPENDENCE OF THE AVERAGE RESIDUAL RESOURCES OF AVIONIC COMPONENTS

With a normal (Gaussian) distribution, a random variable can take any value from $-\infty$ to $+\infty$. Since the possible values of random output and failure can only be positive, the theory of reliability is widely used in the logarithmically normal distribution of the species:

$$f_{\xi}(t) = \frac{1}{\delta t \sqrt{2\pi}} \exp \left[-\frac{(1nt-a)^2}{2\delta^2} \right],$$

where a is the scale parameter;

δ is the shape parameter;

$a > 0, \delta > 0$.

For this distribution law, the probability of failure-free operation is calculated from the tabular values of the normal distribution $\Phi_{\xi}(t)$ given in DSTU 2862-94

$$P(t) = \Phi \left(\frac{a-1nt}{\sigma} \right),$$

$$\text{where } \xi(t) = \frac{1}{\sqrt{2\pi\sigma}} e^{-\frac{(e-a)}{2\sigma^2}},$$

a - mathematical expectation;

σ is the standard deviation of the random variable t .

The failure rate is defined as

$$\lambda(t) = \frac{\exp \left[-\frac{([1nt-a])^2}{2\sigma^2} \right]}{\sigma t \sqrt{2\pi\phi \left(\frac{a-1nt}{\sigma} \right)}}$$

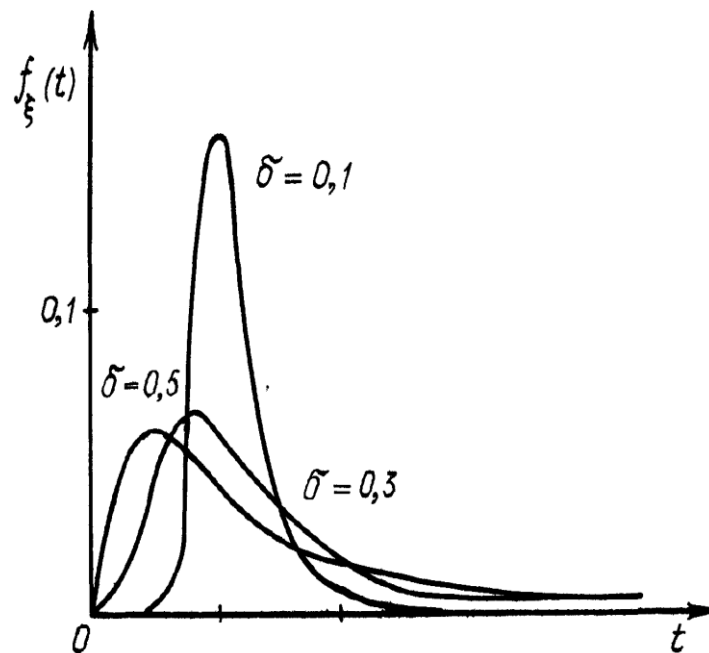

Fig. 15. The density of the logarithmic-normal distribution

Average operating time before failure T_1

$$T_1 = \exp\left(a + \frac{\sigma^2}{2}\right)$$

This function of distribution of operating time to failure is used for conditions when the main type of destruction is fatigue, which is due to the periodic process of loading.

3.1. Initial data and calculation program dependence of average residual resources on average operating time blocks to failure

Determine the composition of the input data to calculate the dependence of the average residual resources from the average operating time of the blocks to failure, namely:

- parameters of the failure distribution scale μ having the dimension [flight hours];
- parameters of the form of distribution of refusal ν ;
- the step of changing the parameters μ and building graphs of residual resources to visualize the results;
- the number of settlement points for compiling a program for calculating average residual resources.

Let us make the following equation having input data of calculation of dependence

$I := 40$ $M := 6$ $\Delta\mu := 5000$ $\nu := 0.55$ $\tau_0 := 1000$ $\Delta\tau := 500$

```

ρμτ :=
  for m ∈ 2..M
    μm ← Δμ·(m - 1)
    for i ∈ 1..I
      τ ← τ0 + Δτ·(i - 1)
      ρμτ1,i ← τ
      a ← [ μm · ( 1 +  $\frac{\nu^2}{2}$  ) - τ ] · cnorm(  $\frac{\mu_m - \tau}{\nu \cdot \sqrt{\mu_m \cdot \tau}}$  )
      b ← 0.5 · μm · ν2 · exp( 2 · ν-2 ) · cnorm(  $\frac{\mu_m + \tau}{\nu \cdot \sqrt{\mu_m \cdot \tau}}$  )
      c ← ν ·  $\sqrt{\frac{\mu_m \cdot \tau}{2 \cdot \pi}}$  · exp(  $-\frac{(\tau - \mu_m)^2}{2 \cdot \nu^2 \cdot \mu_m \cdot \tau}$  )
      ρμτm,i ← a + b + c
    return ρμτ

```

Fig. 16. The results of the calculation of the dependence $\rho = (\mu, \tau)$ at $\nu = 0.55$

Figures 16 show graphical representations of the calculation results for different parameters of the forms of distribution of failures.

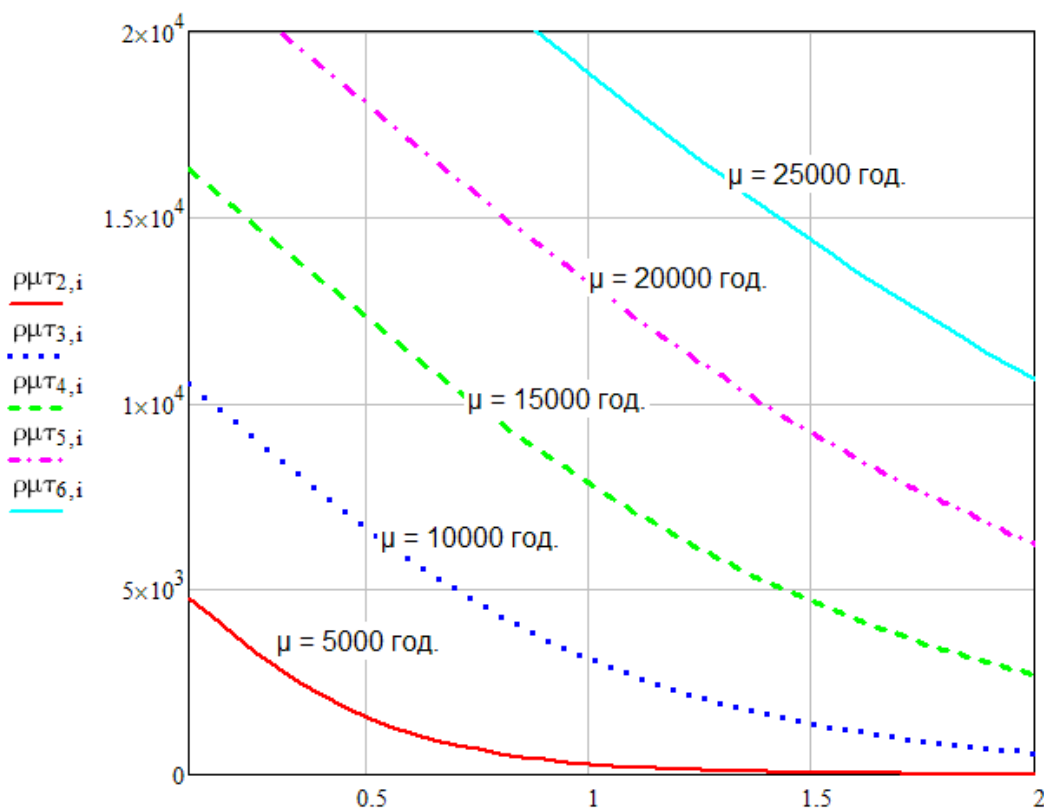

Fig.17. Duration of trouble-free operation at = 0.55

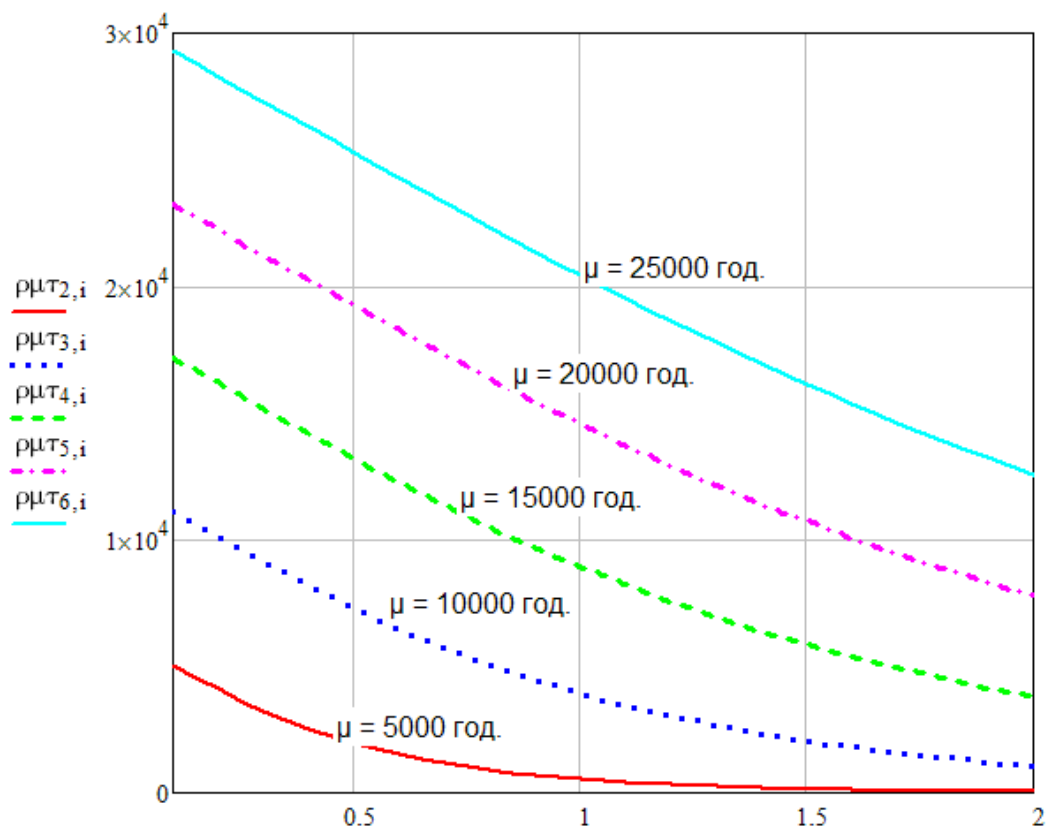

Fig.18

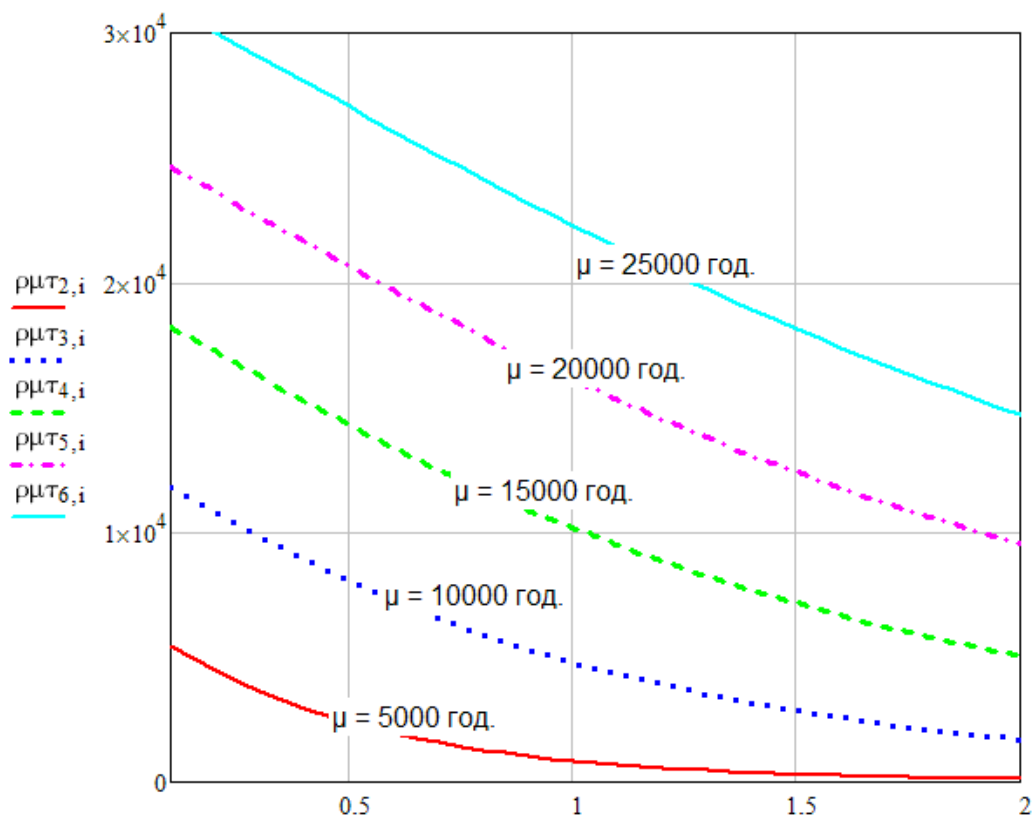

Fig. 19.

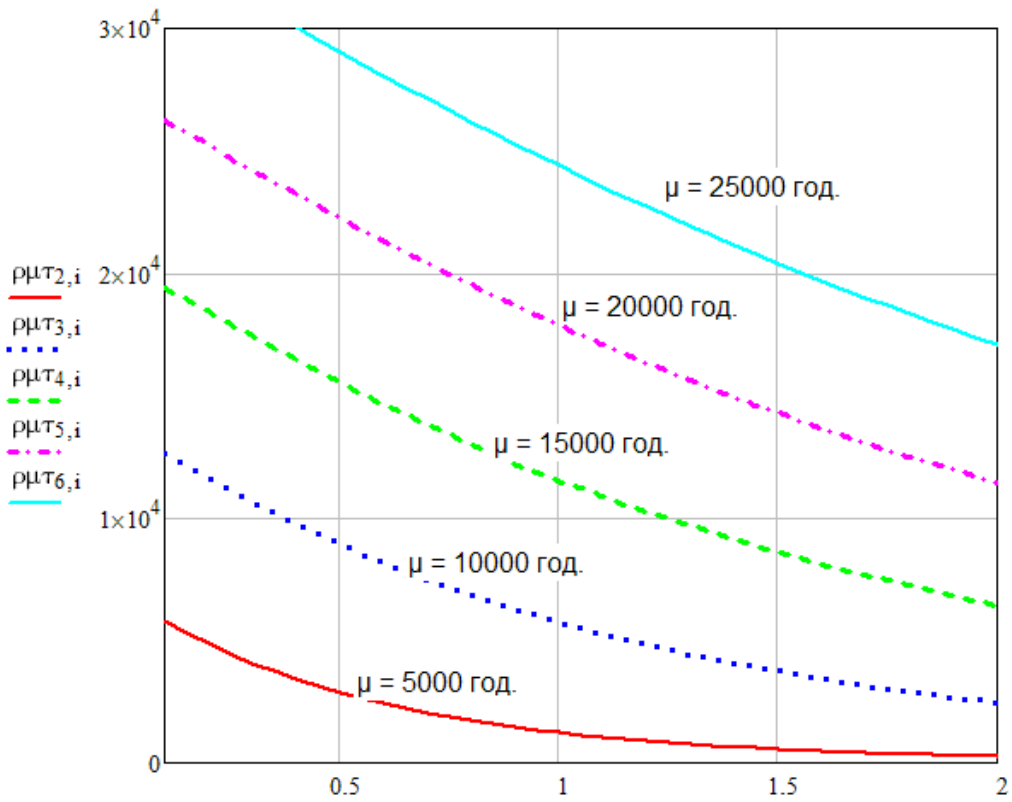

Fig. 20.

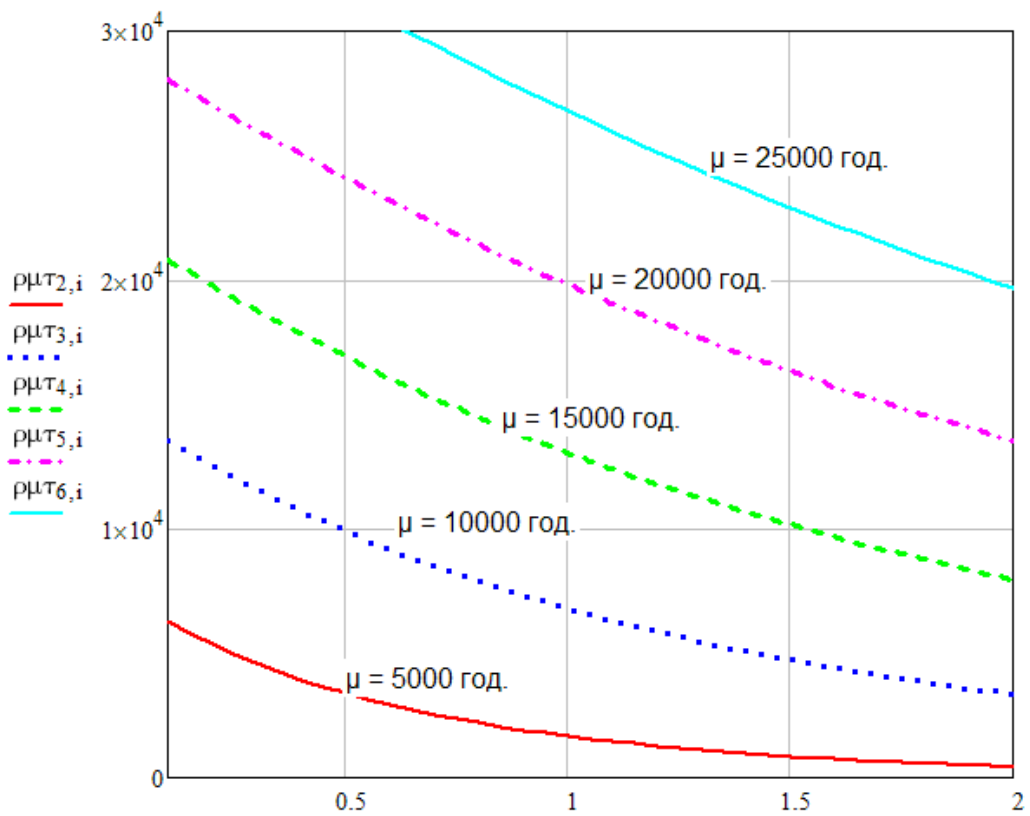

Fig. 21.

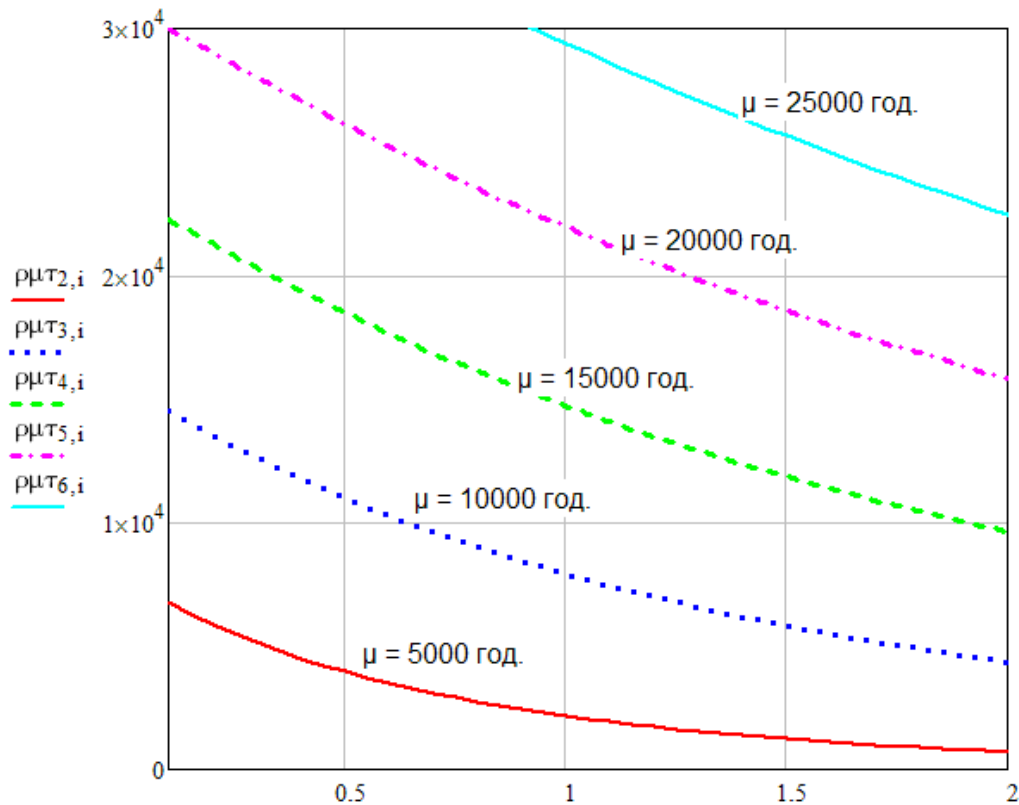

Fig.22.

3.2. Initial data and program for calculating the dependence of average residual resources on the coefficient of variation of the average operating time of blocks to failure

It is known that quantitative indicators of reliability can be defined in two ways:

- calculation of reliability indicators by probabilistic methods at the design stage through the indicators of constituent elements (indirect evaluation methods) with modelling of the operation process;

- calculation of reliability indicators according to statistical data (direct evaluation methods), ie based on the results of monitoring the operation of the product or from a specially set experiment.

Thus in the processing of statistical material, there are some questions. How to estimate the unknown probability of a random event based on observations? How to estimate the unknown distribution function of a random variable from the values obtained from the experiment? How to estimate the parameters of the distribution law, if the type of distribution function is provided to us is known.

These issues are important for solving practical problems of reliability theory. They form the basis of research in mathematical statistics. However, not all her

questions are reduced to them. Along with the posed, in practice there are always questions of another kind: for one reason or another to put forward some general hypotheses, for example, a random event has a certain probability in these conditions, or this random variable is supposed to have an exponential distribution law. How do test the accuracy of the hypotheses?

Mathematical statistics as a science deals with methods of processing a large amount of experimental data to obtain correct conclusions from them.

Methods of mathematical statistics make it possible to present a large number of observational results in a compact, easy to define form. They make it possible to extract significant information from a multitude of observations, presenting it in the form of a small number of summary indicators. If it turns out that the available data are not enough to understand the essence of the phenomenon and require additional experimentation, the methods of mathematical statistics can answer the question of how to set up such an experiment to minimize the researcher's work both in setting up the experiment and further processing experimental data.

Determine the composition of the initial data to calculate the dependence of the average residual resources on the coefficient of variation of the average operating time of the blocks to failure, namely:

- parameters of the failure distribution scale μ having the dimension [flight hours];
- parameters of the form of distribution of refusal ν ;
- the step of changing the parameters μ and ν to build graphs of residual resources to visualize the results;
- the number of settlement points for compiling a program for calculating average residual resources.

Let's make the following equation having initial data of calculation of dependence

```

    v0 := 0.55    Δv := 0.10    M := 7
ρvτ := for m ∈ 1..M
    | v_m ← v0 + Δv·(m - 1)
    | for i ∈ 1..I
    | | τ ← τ0 + Δτ·(i - 1)
    | | ρvτ1,i ← τ
    | | a ← [ μ · [ 1 + (v_m)^2 ] - τ ] · cnorm( ( μ - τ ) / ( v_m · √( μ · τ ) ) )
    | | b ← 0.5 · μ · (v_m)^2 · exp[ 2 · (v_m)^-2 ] · cnorm( - ( μ + τ ) / ( v_m · √( μ · τ ) ) )
    | | c ← v_m · √( μ · τ ) / ( 2 · π ) · exp[ - ( τ - μ )^2 / ( 2 · (v_m)^2 · μ · τ ) ]
    | | ρvτm,i ← a + b + c
return ρvτ

```

Fig.23.

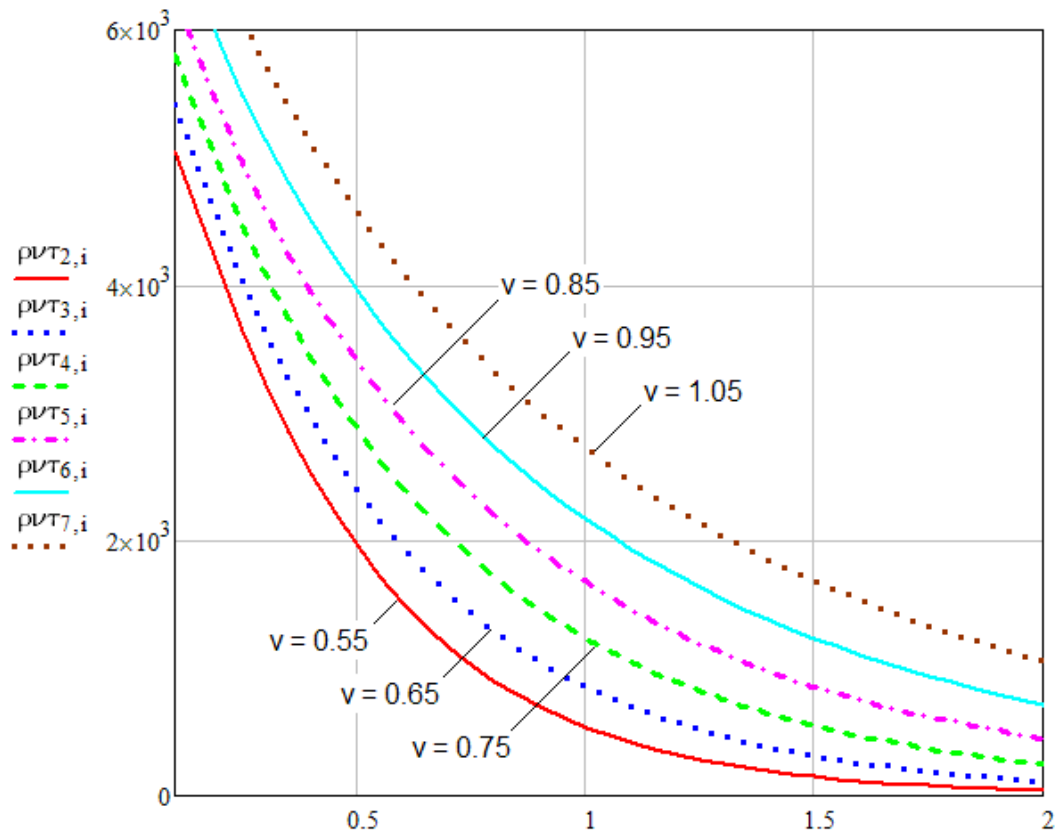

Fig.24

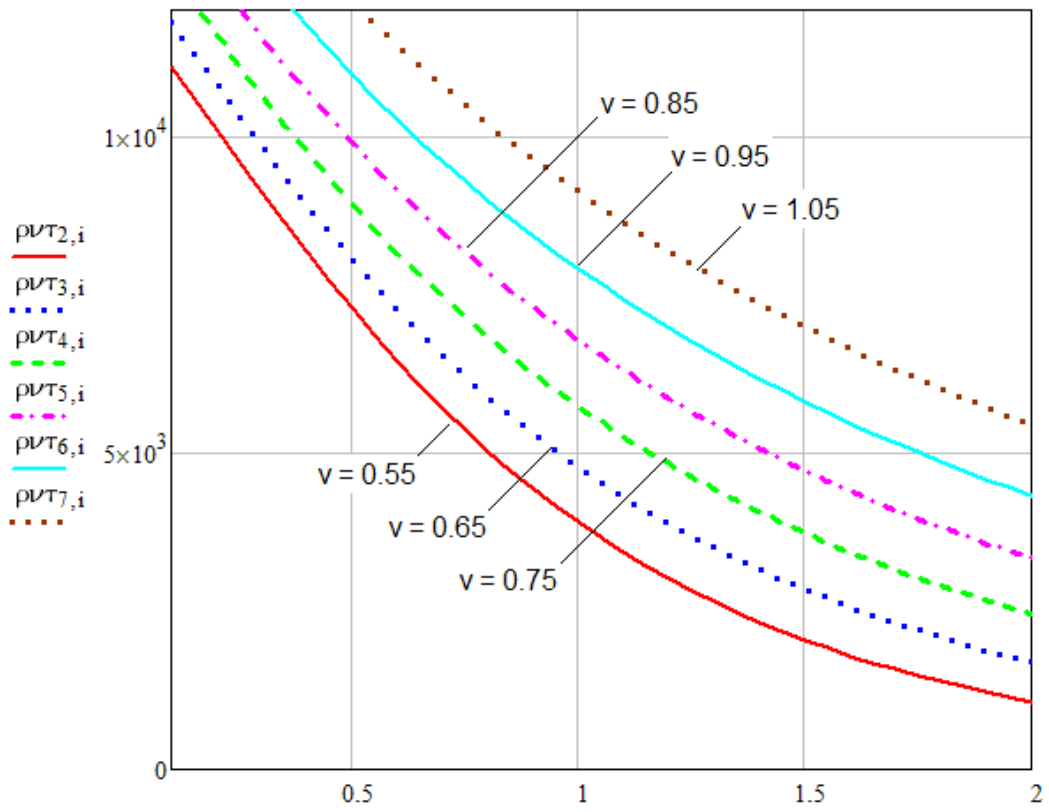

Fig.25.

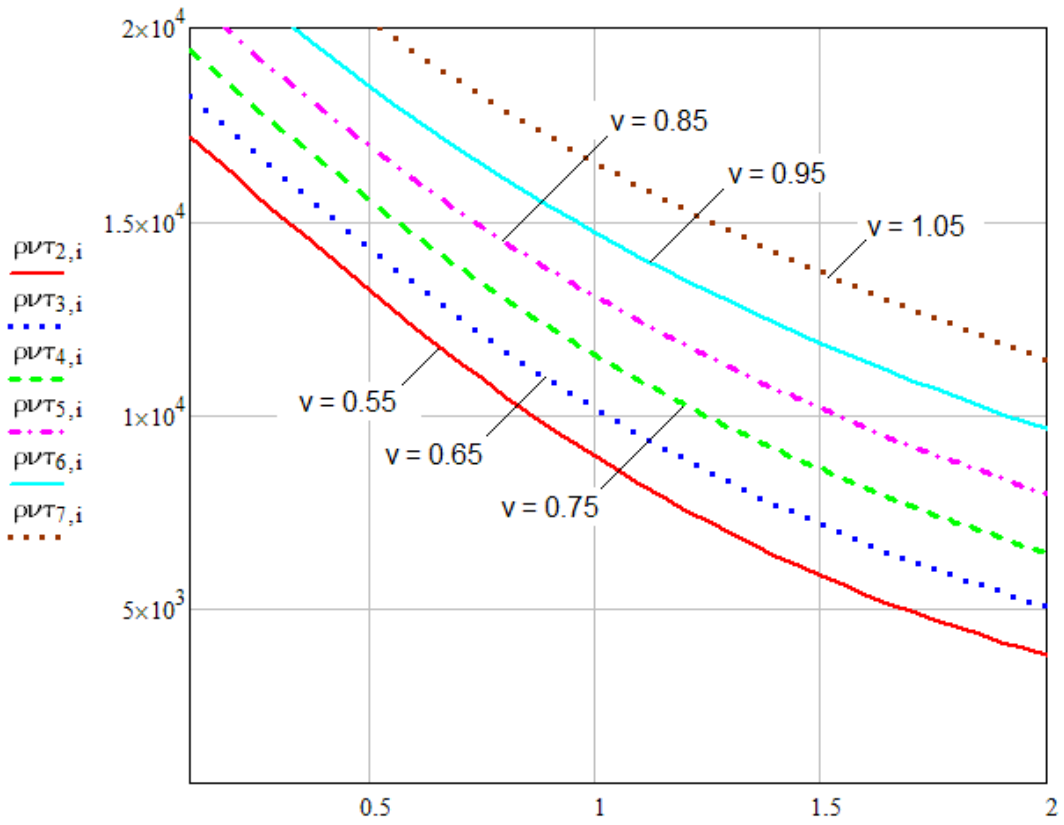

Fig.26.

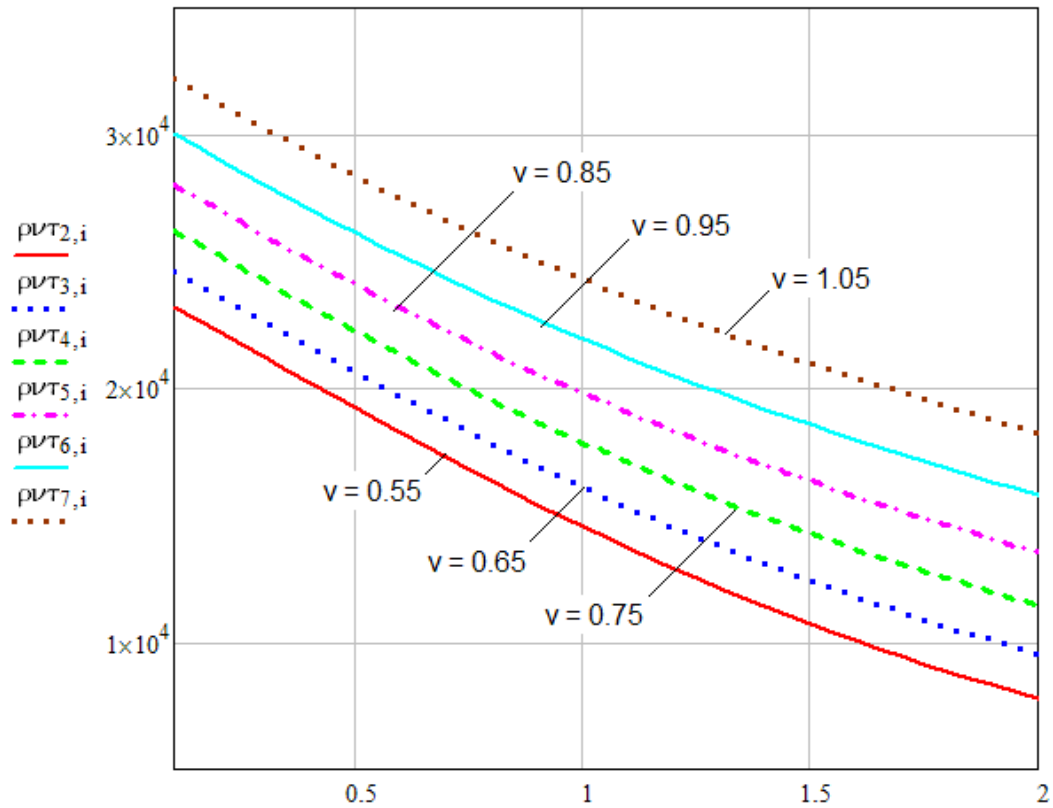

Fig.27.

With the increase of the average operating time of the components of avionics (blocks) μ , the fixed coefficient of variation of the resource v and the fixed interval of trouble-free operation, the τ value of the residual resources of the average resources increases significantly. Thus, if at $\mu= 5000$ flight hours and a fixed value $\tau= 10000$ flight hours, the average residual life is $\rho= 290$ flight hours, then at $\mu= 10000$ average residual life is $\rho= 3106$ flight hours (for $v= 0.55$), as follows from Fig. 16.

As the coefficient of variation of the resource and the same values of the parameters increase, the μ average τ residual resource rises. Thus, at a fixed value of $m = 10000$ and $\tau= 10000$ flight hours, the coefficient of variation of the resource changes v from 0.55 to 1.05 leading to an average residual resource from 535 to 2717 flight hours (Fig. 27)

CONCLUSIONS

Summing up the results performed thesis it is possible to highlight the following basic results:

1. The avionics of modern aircraft is created based on highly integrated systems of onboard radio-electronic equipment, onboard digital computer systems and information exchange systems. Moreover, we are talking about new principles of construction of avionics and its main functional elements (engine control systems, aerobatic navigation system, communication and life support systems), and about means of support, including control and verification equipment and operational and technical documentation, following which routine work is carried out and certification procedures for onboard aircraft equipment are carried out.

Characteristic features of modern avionics should be noted:

1. Unification of equipment;
2. Reducing the load on the crew;
3. Improving fault-tolerance based on structural, informational and functional redundancies;
4. Installation on board of aircraft onboard systems to prevent collisions of aircraft in the air;
5. Expansion of hardware integration of systems due to the transition to crate structures and the modular principle of construction of integrated systems.

Another specific feature of highly integrated avionics should be software failures (software) that self-destruct after restarting programs.

2. Currently, the problem of flight safety is the most pressing problem of modern aviation, which depends on the level of reliability of aircraft. Flight safety is not only an indicator of the effectiveness of the automated technological complex crew - aircraft, but also a necessary condition for its operation. In-flight work there are cases when due to various circumstances and reasons there are violations of the conditions of the flight task, which complicates the flight or makes it dangerous. It is possible to name three reasons, or rather, three groups of so-called emergency factors that _ create threats to security flights:

1 - dangerous refusals aviation in-flight equipment, in particular: failures power plant, system control, aerobatic, power systems, takeoffs devices, systems livelihood ;

2 - human a factor that includes errors and gross violation crew while piloting _ aircraft, errors flight and engineering staff during training _ aviation flight techniques, errors and violations in the organization and management by air movement, poor quality implementation of preventive and repair works and others factors that _ accepted consider subjective ;

3 - unfavourable conditions flight: atmospheric turbulence and thunderstorms cloudy, foggy and sandy storm, icing aircraft, collisions with birds and other factors that _ accepted considered objective.

3. The main content of measures aimed at maintaining the airworthiness of the aircraft is a set of maintenance work (MA) and repair of aircraft during operation. It is associated with the transition from static (rigid) to dynamic (flexible) forms of management processes technical maintenance and repair of aircraft. The role of the current one is growing information on changes in operating conditions and technical condition of the aircraft fleet airlines in the system management technological processes.

4. An exhaustive characteristic of any random variable, including random durations, is the probability distribution of this random variable or distribution function. Regardless of the complexity, each product (element, functional system, complex system with redundancy) has its function of distribution of time.

Thus, the construction of the reliability model, ie the calculation of the probability of failure-free operation as a function of operating time, involves determining the analytical expression for the density of operating time before failure, given that the application of a theoretical failure model determines the accuracy of calculated quantitative reliability.

An analytical expression for the density of the distribution of operating time to failure can be obtained in two fundamentally different ways :

1) based on the analysis of statistical data from operating time to failure (resource, term of faultless storage, etc.);

2) based on the analysis of physical processes of degradation in the elements of the product, which lead to failure (limit state).

5. For technical products and systems in which failures of mechanical elements are predominant, normative documents recommend the use of D N - *distribution* as a theoretical model of the distribution of operating time before failure (limit state). The diploma company presents the calculation dependencies for estimating the residual resources of products based on DM - the failure model for the residual resource and gamma-percent residual resource. Thus, in the thesis, the probabilistic-physical method offers to calculate the reliability of a simple mathematical apparatus for predicting the residual resources of products and systems of avionics.

6. This paper presents a program for calculating the dependence of average residual resources on the average operating time of blocks to failure, as well as a program for calculating the dependence of average residual resources on the coefficient of variation of average operating hours of blocks to failure. The impact of failure parameters on the average residual resources of avionics components is as follows:

1. With the increase in the average operating time of the components of avionics (LRU Line Replaceable Units), the fixed coefficient of variation of the resource and the fixed interval of trouble-free operation, the value of residual resources increases significantly.

2. As the coefficient of variation of the resource increases, the average residual resource rises.

