

**МІНІСТЕРСТВО ОСВІТИ І НАУКИ УКРАЇНИ
НАЦІОНАЛЬНИЙ АВІАЦІЙНИЙ УНІВЕРСИТЕТ
АЕРОКОСМІЧНИЙ ФАКУЛЬТЕТ
КАФЕДРА АВІАЦІЙНИХ ДВИГУНІВ**

ДОПУСТИТИ ДО ЗАХИСТУ

Завідувач кафедри

д-р техн. наук, проф.

_____ Ю.М. Терещенко

«__»_____ 2022 р.

**КВАЛІФІКАЦІЙНА РОБОТА
(ПОЯСНОВАЛЬНА ЗАПИСКА)**

**ЗДОБУВАЧА ОСВІТНЬОГО СТУПЕНЯ МАГІСТРА
ЗА ОСВІТНЬО-ПРОФЕСІЙНОЮ ПРОГРАМОЮ
«ТЕХНІЧНЕ ОБСЛУГОВУВАННЯ ТА РЕМОНТ
ПОВІТРЯНИХ СУДЕН І АВІАДВИГУНІВ»**

Тема: «Система діагностування парку авіаційних двигунів»

Виконав: _____ **Фейчен Чжао**

Керівник: канд. техн. наук, доц. _____ **П.В. Корольов**

Консультанти з окремих розділів пояснювальної записки:

охорона праці: канд. техн. наук, проф. _____ **Б.Д. Халмурадов**

**охорона навколишнього середовища:
канд. техн. наук, доц.** _____ **Л.І. Павлюх**

Нормоконтролер _____ / _____ /

Київ 2022

**MINISTRY OF EDUCATION AND SCIENCE OF UKRAINE
NATIONAL AVIATION UNIVERSITY
AEROSPACE FACULTY
AEROENGINE DEPARTMENT**

PERMISSION FOR DEFENCE

Head of Department
Doctor of Sciences (Engineering), prof.
_____ U. Terechenko
" _____ " _____ 2022

**QUALIFICATION WORK
(EXPLANATORY NOTE)**

ON THE EDUCATIONAL PROFESSIONAL PROGRAM
« MAINTENANCE AND REPAIR OF AIRCRAFTS AND AIRCRAFT ENGINES »

Theme: «System of diagnosing the fleet of aircraft engines »

Performed by: _____ **FeiCheng Zhao**

Supervisor:
Ph.D. (Engineering), assoc. prof. _____ **Korolev Peter**

Advisers:
Labor protection:
Ph.D. (Engineering), assoc. prof. _____ **Khalmuradov Batyr**

Environment protection:
Ph.D. (Engineering), assoc. prof. _____ **Pavluh Lesia**

Standards Inspector: _____ / _____ /

Kyiv 2022

NATIONAL AVIATION UNIVERSITY

Faculty: Aerospace

Department: Aeroengine department

Educational degree: Master

Specialty: 272 «Aviation Transport»

Educational Professional Program: «Maintenance and repair of aircrafts and aircraft engines»

APPROVED BY

Head of Department

_____ U. Terechenko

«__» _____ 2022 p.

Assignment for Qualification Work

FeiCheng Zhao

(surname, name and patronic of applicant)

- 1. The work topic:** «System of diagnosing the fleet of aircraft engines», approved by the Rector's order of October 25, 2022 №2021/CT.
- 2. The project must be performed** from 26.09.2022 to 30.11.2022.
- 3. Initial data for the project:** The results of the analysis of existing systems for monitoring the technical state of aviation gas turbine engines. Information about modern methodical and technical achievements for improving the diagnosing of gas turbine engines.
- 4. The content of the explanatory note:** Analysis of approaches to improvement of systems of technical diagnosing of aviation engines. Basing of the expediency and development of proposals for improvement of checking on technical state of aviation gas turbine engines. Labour protection. Environment protection.
- 5. The list of mandatory graphic materials:** Illustrations of methodical and constructive solutions regarding the improvement of gas turbine engines diagnosing systems.
- 6. Time and work schedule**

№	Stages of completion of the work	Completion date	Remarks
1	Results of analysis of the prospects for the development of technical diagnosing systems	30.09.2022	
2	Basing of the expediency of improving the gas turbine engines diagnosing systems	14.10.2022	
3	Development of proposals for improving the diagnosing procedures for aviation gas turbine engines	14.11.2022	
4	Analysis of harmful factors during the aviation gas turbine engines operating. Development of measures for labor protection.	28.10.2022	
5	Identification of priority areas for reducing the harmful impact of aviation gas turbine engines on the environment	04.11.2022	
6	Writing parts «Environment Protection» and « Labor protection»	11.11.2022	
7	Design of the work and presentation	18.11.2022	

7. Advisers on individual sections

Section	Adviser	Date, Signature	
		Assignment delivered	Assignment accepted
Labor protection	<i>Khalmuradov Batyr</i>		
Environment protection	<i>Pavliukh Lesia</i>		

8. Assignment issue date: «26» september 2022.

Qualification work supervisor _____ Korolev Peter
(signature)

Assignment is accepted _____ FeiCheng Zhao
(signature)

ABSTRACT

Explanatory note to the qualification work: «System of diagnosing the fleet of aircraft engines»:

page., fig., table., sources used.

The *object* of research is an aircraft gas turbine engine.

The *subject* of the study is the diagnosis of a gas turbine engine using various methods.

The *purpose* of the work is to analyze and develop methods of oil analysis and control, as an important tool in any maintenance program, which provides valuable information about the condition of the oil and, as a result, about the condition of the engine; analysis of the principle and procedure of operation of modern oil spectrometers, their capabilities and advantages; a study of online monitoring of lubricant condition and prediction of residual life using the particle filtering method and available online sensors of various existing global manufacturers was carried out, and monitoring of lubricant condition and detection of degradation of gas turbine engines was given, viscosity and dielectric constant were selected as operating parameters for modeling lubricant degradation materials; the analysis of the basics and methods of laser vibrometry is carried out, the types of existing vibrometers and vibroanalyzers are given, the advantages of laser vibrometry, which consist in huge measurement ranges, high accuracy and reliability, are considered.

Research methods. Elements of the theory of gas turbine engines, methods: mathematical, real-life, computer modeling were used to solve the tasks.

The practical significance of the results of the work consists in increasing the efficiency of diagnosing gas turbine engines by increasing the probability of an accurate technical diagnosis when identifying the technical condition of the gas turbine to the structural unit.

The recommendations developed by the author can be proposed to improve the methods and means of diagnosing gas turbine engines.

**DIAGNOSTICS, GAS TURBINE ENGINE, TECHNICAL
CONDITION, OIL SPECTROMETER, SENSOR, MONITORING,
VIBROMETER, VIBROANALYZER**

CONTENT

LIST OF ABBREVIATIONS.....	6
INTRODUCTION.....	7
PART 1 BASICS OF TECHNICAL DIAGNOSTICS.....	9
1.1 Basic concepts, terms and definitions.....	9
1.2 Tasks and structure of technical diagnostics.....	
Conclusions to part 1.....	
PART 2 CHARACTERISTIC OF THE DIAGNOSTIC	
OBJECT.....	
2.1 General information.....	
2.2 Brief description of the design and power scheme of the engine.....	
Conclusions to part 2.....	
PART 3 IMPROVEMENT OF DIAGNOSTICS OF GAS TURBINE	
ENGINES.....	
3.1 Methods of oil analysis and control.....	
3.2 Improvement diagnosis online industrial lubrication oil and quality condition monitoring.....	
3.3 Analysis and basics of laser vibrometry.....	
Conclusions to part 3.....	
PART 4 ENVIRONMENTAL PROTECTION.....	
Conclusions to part 4.....	
PART 5 LABOR PROTECTION.....	
Conclusions to part 5.....	
GENERAL CONCLUSION.....	
LIST OF SOURCES USED.....	

List of abbreviations

AE	aviation equipment
ABV	air bypass valves
ADS	automated diagnostics system
ACS	automated control system
AE	aviation equipment
FS	flight safety
GTE	gas turbine engine
DP	diagnostic parameter
EC	electronic computer
CHP	high pressure compressor
CLP	low-pressure compressor
CMP	medium pressure compressor
MM	mathematical model
EDD	entrance directing device
THP	turbine of high pressure
TMP	turbine of medium pressure
TLP	turbine of low pressure
NZ	nozzle device
CLE	control lever by the engine
TPA	taps for passing air
GA	guide apparatus
TD	technical diagnostics
MS	maintenance service
TS	technical state

INTRODUCTION

The significance of solving diagnostic problems is formed by the urgent need for an effective analysis of the technical condition of aircraft at all periods of the life cycle - both during design and production, and during operation and repair.

A large set of parameters of various physical nature is used in the diagnostics of aviation equipment, as one of the most difficult technical systems. To select a diagnostic indicator when performing a diagnostic task with finding the nature of the defect, the degree of development, and, most importantly, especially the forecast of the technical condition, a considerable amount of information is required.

In the general case, diagnostics, being to some extent both a scientific discipline and an area of scientific and practical activity that is socially conditioned, is transformed in the process of the historical development of society. This modern development in the current century takes place in the direction of increasing the possibilities of a more accelerated and accurate approach to the very purpose of diagnostics, determining the causes of deviations from the normalized parameters of a technical object. At the same time, the improvement of diagnostics is characterized by great unevenness and rapid variability of its various aspects, as well as the dependence and influence on each other of all kinds of signs and parameters of controlled both individual units and mechanisms, and technical objects as a whole, in terms of information content, and possibly even from the point of view of the redundancy of the flow of information. This is the case for all levels and sections of diagnostics.

Thus, technical diagnostics is the science of recognizing (belonging to one of the possible classes) the state of a technical system. When diagnosing an object, it is established by comparing the knowledge accumulated by science about the group and class of the corresponding objects [1].

Technical diagnostics is a science that appeared in connection with the increasing role of complex and rather expensive technical systems in the national economy and the presentation of serious requirements for safety, reliability and

durability. In connection with the foregoing, in relation to aviation equipment (AE), the failures of which lead to very difficult results, special increased requirements are imposed.

Prevention of accidents and catastrophes is largely determined by the effectiveness of methods and means of their diagnostics. The requirement for the need for a technical condition monitoring system (TC) of aviation equipment is directly in such a fundamental document as the Aviation Regulations AR-25 “Airworthiness Standards for Transport Category Aircraft” [2]. According to the conditions of these requirements, for on-board systems, as a result of failure or incorrect operation of which an emergency situation may arise directly in flight, it is mandatory to monitor and diagnose the technical condition [2].

During the operation of aviation equipment, the occurrence of all kinds of failures and malfunctions of various physical nature is typical. Such a wide range of failures and malfunctions of aviation equipment cannot be determined, and more importantly, prevented by one diagnostic method. Practical experience confirms that in order to determine all kinds of AE malfunctions, a developed diverse system of technical diagnostics is required, which in its activity will be based on a combination of various methods and tools [3].

PART 1

BASICS OF TECHNICAL DIAGNOSTICS

1.1 Basic concepts, terms and definitions

Technical diagnostics (TD) is a field of knowledge that includes theory, methods and means for determining the technical condition of an object, including an aircraft gas turbine engine (GTE). Like any other science, it uses concepts, terms and definitions that are found both in the literature on general issues of technical diagnostics and during the diagnostics of aviation equipment, including the diagnostics of aircraft engines.

In technical diagnostics, concepts, terms and definitions are used, the meanings of which are established by state standards [4,5,6]. In addition, there are many terms and concepts that are not included in the standards, but are used in scientific, technical and educational literature [7,8]. The following are the most commonly encountered and used terms and definitions.

In the definition of TD, the most basic, one might say the key term, is the concept of «technical condition». *The technical condition* of an object is understood as a set of properties of an object that can be changed during production or use, described in specific time parameters (state parameters) that are set in the technical documentation for this object.

The object of technical diagnostics is the product and (or) its components subject to (can be) diagnosed. That is, it is a material object, the technical condition of which is determined and, as a result, a technical diagnosis is established. For diagnostics, it is necessary to assess the compliance of the parameters with the requirements of regulatory and technical documentation [2,3,4].

A state parameter is a value that quantitatively characterizes one of the main properties of an object or a process occurring in an object. Mass, friction coefficient, geometric dimensions, gaps, electrical resistance, etc. can be taken as state parameters. These parameters are also called primary. Experimental evaluation of the numerical values of these parameters and their comparison with

the values established by the regulatory and technical documentation, and allows you to assess the technical condition of the object, that is, to establish its diagnosis [3,4,5].

Often in reality it is difficult, we can say that it is impossible, to directly measure the parameters of the state. Proceeding from this, the term of diagnostic parameters (DP) was introduced in technical diagnostics, which means the parameters of the object used in diagnosing. These parameters in the technical literature are sometimes called secondary. In the role of DP, both the parameters of the technical state and the parameters describing all kinds of processes that occur in the object of diagnosis, and only indirectly related to the state parameters, are used.

Thus, the analysis of the technical condition is carried out on the basis of information about the indicators of diagnostic parameters. It follows that it is imperative to understand the relationship between diagnostic parameters and status parameters. This dependence is displayed using the so-called mathematical (diagnostic) models [9].

A mathematical model is a formalized description of an object that is necessary for solving diagnostic problems. It should also be noted that the main purpose of the mathematical (diagnostic) model is to find and fix the relationship between the values of diagnostic parameters and the values of the parameters of the technical condition (or directly with the technical condition) [7,8,9].

As a result, the implementation of diagnostics can be represented as follows (Fig. 1.1). The object of control with the parameters of the technical condition Z experiences an external influence X . Using various measuring instruments, diagnostic parameters Y are found. Using a mathematical model, the values of these parameters are recalculated into the values of the parameters of the technical condition of the Z^M . Subsequently, these values are compared with the values of the parameters of the technical condition, according to the normative and technical documentation of the Z^{ND} , and taking into account these final results, a conclusion

is made about the technical condition of the control object.

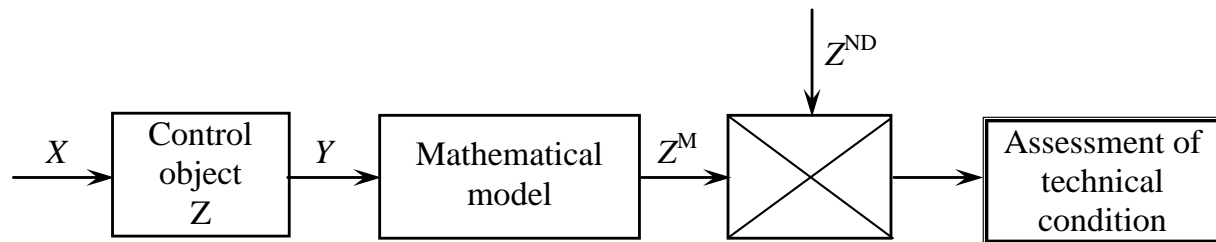

Figure 1.1 – Schematic representation of the definition process technical condition

The mathematical description (model) of the object of diagnosis can be performed both with the use of diagnostic parameters and with the use of diagnostic signs. The difference between these two concepts is as follows. *Diagnostic signs* are formed (elected) on the basis of diagnostic parameters, they form a discrete set, and the appearance of their specific values is directly related to finding the object of diagnosis in the appropriate class of technical condition (diagnosis). For example, let the diagnostic parameter expresses the temperature of the gases behind the turbine of an aircraft engine. Let us define three classes of technical condition of the engine, which are characterized by respectively reduced ($<450^{\circ}\text{C}$), normal ($450\text{-}600^{\circ}\text{C}$) and increased ($>600^{\circ}\text{C}$) temperature. The hit of the gas temperature value in one of these intervals is the appearance of a diagnostic sign that corresponds to the engine with a reduced, normal or elevated temperature.

The purpose of mathematical (diagnostic) models (MM) is not only to establish a relationship between the state parameters and diagnostic parameters. MM allow to make algorithms of technical diagnostics.

The algorithm of TD is a set of regulations that define the sequence of actions at carrying out of diagnostics.

Depending on the time for which the diagnosis is carried out, there are three types of diagnostic tasks. The first type is the problem of determining the technical condition in which the object was at some point in time in the past – genesis problem. This type of problem is solved mainly in the investigation of aviation

accident and the prerequisites for them (fig. 1.2).

The second type is the task of determining the technical condition of the object at a given time, which are called diagnostic tasks. This type of task is important when performing maintenance and deciding on future operations.

The third type is the problem of predicting the technical condition in which the object will be in the future moment of time – the problem of forecasting. This type of problem is important for predicting (forecasting) residual resource.

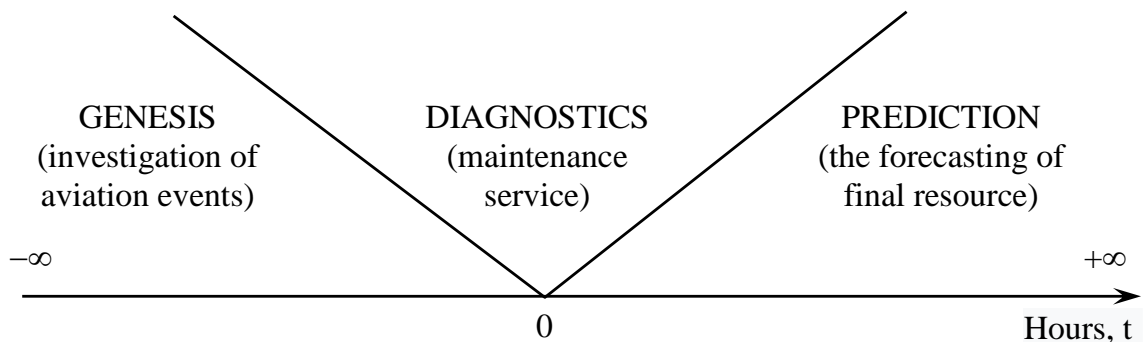

Figure 1.2 – Types of diagnostic tasks

The ultimate goal of diagnosing at the final stage is interconnected with the tasks of classification, since it is necessary to establish a diagnosis based on the existing information, that is, to determine the class of the technical condition of a given object. For such a detailed classification, it is necessary to understand the classes (diagnoses) that are available and accepted before diagnosis based on the analysis of this object, its functions and the failures that appear in it. In fact, the number of such classes can be infinite. But there are also quite general types of classification, which are known to us from the theory of reliability. In the theory of reliability, there are concepts of four types of TC. [5]:

- ✓ Efficient and unworkable;
- ✓ Serviceable and faulty.

In technical diagnostics two more types of technical condition are introduced [5]:

State of proper functioning and state of improper functioning.

State of proper functioning – means that the object is currently performing

the proposed algorithm of functioning.

State of improper *functioning* – means that the object at the current time does not perform the proposed algorithm of functioning.

It is necessary to distinguish the terms "control of technical condition" and "diagnosis of technical condition".

Control of the TC is a check of conformity of values of parameters of object to requirements of technical documentation and definition on this basis of one of the set types of a technical condition. For example, if an assessment of the technical condition concludes that the object is serviceable or faulty.

The term *technical diagnosis* is used when the main task of the diagnostic process is to find the place and determine the causes of failure, malfunction or improper functioning.

There are a number of other terms that should be mentioned.

Method of control (diagnostics) – rules of application to the object of control (diagnostics) of certain principles and means of control (diagnostics). The choice of a method of control or diagnostics is based on the analysis of physical features of the course of working processes and the development of faults in the object that is diagnosed.

Means of technical diagnostics (control) – equipment and software, with the help of which the determination of the value of diagnostic parameters, their processing and division of objects into classes is carried out.

The system of technical diagnostics (control) – a set of means, object and executors necessary for carrying out diagnostics (control) according to the rules established in the normative and technical documentation.

1.2 Tasks and structure of technical diagnostics

Technical diagnostics of aviation equipment solves a huge range of problems, but at the same time, its main task is to recognize the state of an object in conditions of insufficient information. The solution of these diagnostic tasks (assigning the object to the number of serviceable or faulty ones) is always

associated with the risk of making a false decision, that is, either a false positive or a defect is missed. It is also necessary to dwell on the fact that the most dangerous damage in terms of its development by the destruction of aircraft equipment can be symbolically divided into three groups [10]:

1) faults very quickly (within fractions of a second or a few seconds) turn into an accident, or, almost the same thing, faults are detected too late with the available diagnostic tools;

2) faults that can develop into an accident within a few minutes, as well as faults whose nature and rate of development cannot be reliably predicted on the basis of the level of knowledge achieved. The occurrence of such faults should be accompanied by the immediate issuance of a signal to the aircraft crew (or test bench personnel) to attract attention, assess the situation and take the necessary measures;

3) faults develop relatively slowly or are existing diagnostic tools at such an early stage that their transition to an accident and the continuation of this flight can be considered almost impossible. Early detection of such faults is the basis for predicting the state of AE.

One of the practical tasks of diagnostic research in the field of dynamics of AE faults development is to minimize the number of faults of the first and second groups and gradually "translate" them into the third, thus expanding the possibilities of early diagnosis and long-term forecasting of AE conditions. A high degree of reliability of the diagnosis not only improves flight safety (FS), but also contributes to a significant reduction in operating costs associated with the violation of the regularity of flights, repair of AE.

Operating experience AE for the diagnostics shows that correctly diagnosed, it is necessary at the first stage to know in advance all possible states on the basis of a priori statistical data and of the probability of situations, and an array of diagnostic features that respond to these conditions. As already noted, the process of qualitative changes in the technical properties of AE occurs continuously, which means that the set of possible states of AE is infinite and even many. One of the

diagnostic tasks is to break down a set of states into a finite and a small number of classes. In each class, conditions that have the same properties selected as classification features are combined. At the same time, the statistical base of the parameters obtained by the above diagnostic methods should be impartial and real. Not all parameters that can be used in the diagnosis are equivalent in terms of the content of information about the functioning of the AE system. Some of them bring information about many properties of working modules at once, others, on the contrary, are extremely poor [1].

Therefore, at the second stage, it is interesting to consider the problems of the relationship of diagnostic parameters, their change and possible influence on each other, as well as to assess the significance of the signs of various functional parameters of AE. It is known that the theory of diagnosis is well described by the general theory of communication, which is one of the sections of control theory [7].

In the service of diagnostics, you can put a mathematical and logical apparatus, a system of mastered concepts and terminology. It is only necessary to find a physical interpretation of abstract formulas and ways of practical implementation of the approaches provided by them.

Thus, in the third stage it is necessary to confirm the significance of diagnostic characters, and to form a diagnosis, and further, to carry out forecasting of the pre-failure condition. This part of the work is associated with the greatest difficulties, since functional systems of AE are multiparametric, but not all parameters are equally significant (informative) in certain specific conditions. The classical diagram of the structure of technical diagnostics is shown in Fig.1.3 [11].

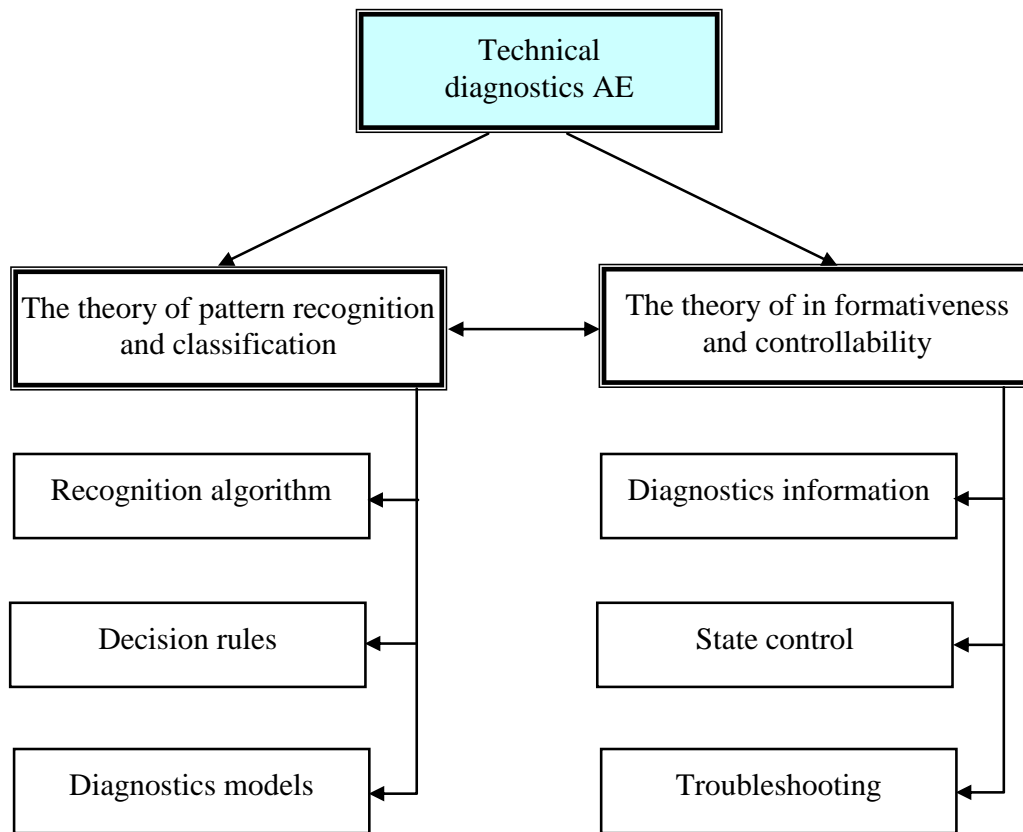

Figure 1.3 – Structure of technical diagnostics

The integrated structure proposed above has two interrelated directions: the theory of identification and the theory of the value of information. The recognition theory has been supplemented with new classification elements and contains items that relate to building recognition algorithms that determine the procedure for identifying control objects and diagnostic models and sorting them. The theory of informativity in this case determines the acquisition of diagnostic data using known methods and diagnostic tools, automated checks with the development of troubleshooting methods, and minimization of the diagnostic process itself. Another set of tasks for technical diagnostics is associated with the regular introduction of diagnostic systems into the practice of operating aviation equipment. A necessary condition for their implementation is the presence of special methods and programs, as well as decision-making algorithms for the subsequent operation of the nuclear power plant. At the same time, modern control and measuring equipment that has passed metrological certification and appropriately qualified personnel are also required.

Conclusions to part 1

This part analyzes the basics of technical diagnostics, provides basic concepts, terms and definitions. The main tasks of technical diagnostics as a field of knowledge covering the theory, methods and means of determining the technical condition of the object, including the aviation gas turbine engine, are also given.

PART 2

CHARACTERISTIC OF THE DIAGNOSTIC OBJECT

2.1 General information

The turbojet engine is designed for installation on regional and mainline airlines. Prototype engines – D-36, D-436T1/T2, D-436-148. Meets both current and future requirements of ICAO standards for aircraft engines on noise and emissions of harmful substances (Fig.2.1).

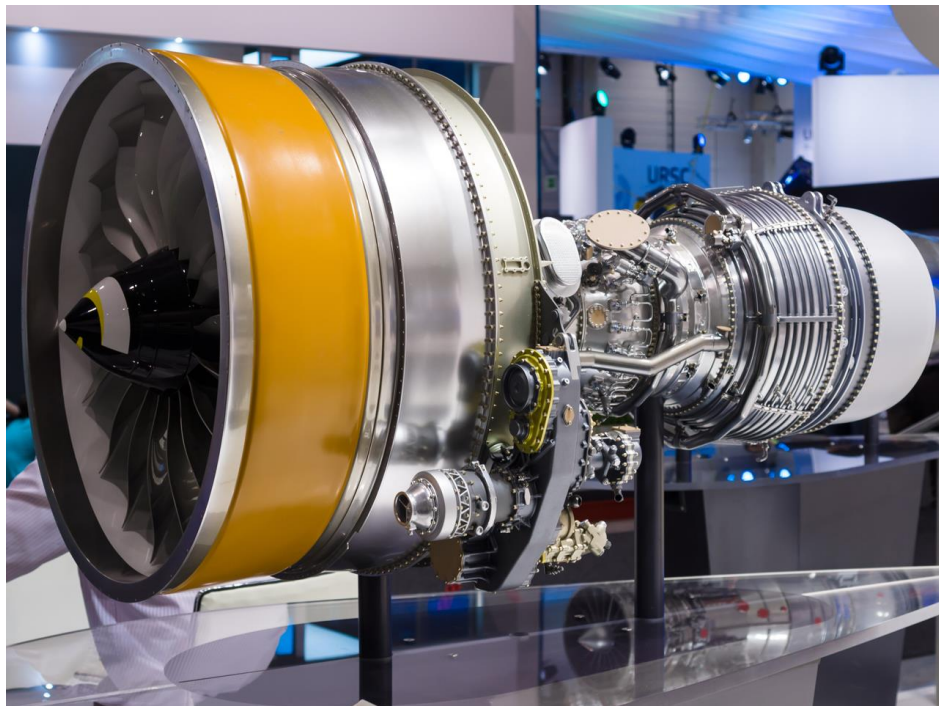

Figure 2.1 – General view of the engine

The high performance of the engine is achieved by:

- using a new fan with improved efficiency and an increased degree of pressure increase in the external circuit;
- installing an additional support protrusion to the compressor;
- a deliberate increase in the gas temperature in front of the turbine.

The universal suspension allows you to use the engine on various aircraft without changing the design, placing it under the wing or above the wing, the fuselage or on both sides of the fuselage [14,15].

2.2 Brief description of the design and power scheme of the engine

Three-shaft the turbojet two-planimetric engine is intended for installation on medium-haul passenger aircraft.

The engine is executed on three-shaft to the scheme with axial fifteen- stage the compressor, the intermediate case, the ring chamber of combustion, the five- stage turbine, the reversive device in external fan a contour and separate noncontrollable target nozzles of external and internal contours. Feature three-shaft schemes – division of a rotor of the compressor into three independent rotors, each of which is resulted in rotation by the turbine (Fig.2.2).

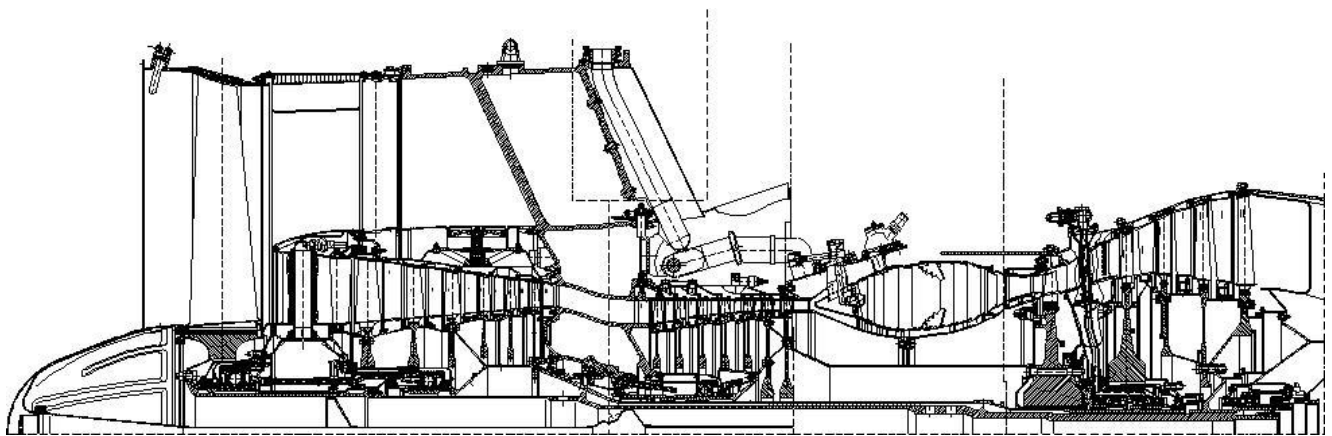

Figure 2.2– Longitudinal section of the engine

Thus rotors have different optimum for them frequencies of rotation and are connected among themselves only gas-dynamic by communication.

The scheme of installation of rotors – six-basic, that is each of three rotors is established on two bearings.

Engine performance on three-shaft has allowed the scheme:

- To apply in the compressor of a step which have high efficiency;
- To provide necessary stocks gas-dynamic stability of the compressor;
- To use for start of engines the low power starting arrangement because at start the starter untwists only a high pressure rotor.

The flowing part of the engine behind the fan is divided into internal and external contours [15,16,17].

The internal contour consists of a flowing part of the compressor, the chamber of combustion, the turbine and a jet nozzle of an internal contour.

The external contour consists of a flowing part of the directing device of the fan and the channel generated by internal surfaces of the reversive device, a nozzle external fan a contour and a cowl gas-generator.

Degree the bypass ratio of the engine on a take-off mode is equaled 4,9.

The big degree the bypass ratio of the engine and high parameters of a thermodynamic cycle provide high profitability of the engine.

The engine design is executed taking into account maintenance of a principle of modular assemblage.

The engine consists of fourteen modules and one submodule, each of which - the finished is constructive-technological knot and can be, except the main (fourteenth) module, is dismantled and replaced on the engine without dismantling of the next modules in the conditions of aerotechnical bases.

Modularity engine designs are provided with possibility of restoration of its serviceability with replacement of modules under operating conditions, and high testability promotes transition from scheduled preventive service to operation on a technical condition [11,12,13,17].

The engine compressor – axial, three-cascade, consists of the supersonic fan, a subsonic retaining step of the fan, the transsonic compressor of average pressure and the subsonic compressor of a high pressure. The one-stage fan has no entrance directing device and consists of the driving wheel, stator with the straightening device in an external contour and the directing device in an internal contour, a shaft with bearing in knot of the conic cook which rotates and is constantly warmed with air. Connection of a disk of the driving wheel of the fan with shaft and the cook – bolt joint, shovels fasten to a disk the lock of "fur-tree" type. Working shovels of the fan have the bandage antivibrating regiments located in a flowing part of an external contour. The straightening device of the fan – a folding design. The internal surface of an external ring of the straightening device has sound-proof

facing. To a forward flange of the case of the fan through the prorate the plane air inlet fastens [15,17].

The directing device of the fan is established on an input in an internal contour in front of the driving wheel of retaining degree. The fan shaft is connected to the fan turbine shaft by slots. Fan and fan turbine form a fan rotor mounted on two bearings. Both bearing units of the fan rotor have lubrication dampers.

The impeller of the booster stage is connected by a bolt connection to the fan impeller at the connection point of the impeller flanges and the fan shaft. The directing device of a retaining step structurally enters in stator the compressor of medium pressure (CMP).

CMP –six-stage, consists from stator and a rotor. The stator divides the air flow behind the fan impeller along the external and internal circuits with its fairing.

In stator are available: forward case CMP with the directing device of retaining degree, noncontrol entrance directing device CMP and knots of forward support of rotors of the fan and CMP; case CMP with directing devices CMP, working rings and valves of air bypass valves (ABV) behind third step CMP for maintenance of steady work of the compressor on low modes [11,15,16,17].

Compressor rotor – a drum-disk design. Disks of the first, second and third steps and the welded drum of the fourth, fifth and sixth steps are connected among themselves and with forward and back shaft by means of bolts. Working shovels of the first step are connected to a disk locks of "fur-tree" type, working shovels with the second on the sixth step - type locks "swallow a tail". Rotor CMP is connected to a rotor of turbine SD with the help thread and form a rotor of low pressure.

Medium pressure rotor is established on two bearing knots which have lubricant dampers. The forward ball-bearing knot is established in an elastic support of type "the squirrel wheel" with the firm terminator of a course.

The compressor high pressure (CHP) – seven-stage, consists of the entrance directing device (EDD) with rotary shovels, a rotor, stator and a check point behind fourth step CHP.

Rotor CHP – a drum -disk design. The welded drum of the first fourth stages, disks of last stages, forward and back shaft are connected among themselves by bolts. Shovels with a disk of the first step are connected by type shafts " swallow a tail" to longitudinal grooves on a disk, shovels with disks with the second on the seventh step are connected among themselves by locks " swallow a tail" to ring grooves in disks.

Rotor CHP incorporates to a rotor of the turbine of a high pressure by means of bolts and form a rotor high the pressure, established on two bearing support.

The forward ball bearing is established in an elastic support of type "the squirrel wheel" with the firm terminator of the course, mounted in the intermediate case. The back roller bearing is established on lubricant dampers in the case of support of turbines.

Rotary shovels EDD CHP allow to make engine adjustment at bench tests. After adjustment of shovel EDD are fixed in the selected position.

The intermediate case serves for formation of the transitive channel from CMP to CHP and a flowing part of an external contour, placing of units and drives to them, and also placing of a forward support of rotor CHP and knots of a forward belt of an engine mount [15,16].

Ring covers of the intermediate case which form a flowing part of internal and external contours, are connected among themselves eight by empty racks in which there pass communications of systems of the engine.

The intermediate case consists of actually intermediate case, the central drive, a box of drives and an intermediate drive. All driven engine units are established on a box of drives and receive rotation from rotor HP through system of tooth gearings and thread springs. To a back flange of an external cover

The intermediate case elements of a design of the reversive device fasten, to a forward flange fan case RD fastens. To an internal ring cover case CMP, and behind - case CHP ahead fastens. On the intermediate case cowl elements gas-generator which form an internal surface of an external contour between racks of the intermediate case are established also.

The combustion chamber consists of the case, entrance diffuser with the straightening device of seventh step CHP, hot pipes, a fuel collector, fuel atomizers and starting igniters.

Hot pipe – ring type, with eighteen fuel atomizers, has a welded design, consists from separate, welded end-to-end, rings which have a number of apertures for pass of secondary air.

Fuel atomizers – centrifugal type, single-channel, four of them – aeroatomizers (with fuel pneumodispersion), that provides proof burning at poorization fuel-air mixes.

Fuel collector and tubes of leading of fuel to atomizers have a protective casing which prevents fuel hit on hot case details in case of infringement of tightness of a collector and tubes of leading of fuel. On the case of the chamber of combustion two igniters of torch type with spark plugs are established [12,15].

In a forward part of the case of the chamber of combustion two valves of restart-up of air for CHP are established at engine start; on one of valves set a branch pipe for air selection for CHP for needs of the plane.

The turbine – three-cascade, five-stage, jet, consists of the one-stage turbine of a high pressure (THP), the one-stage turbine of medium pressure (TMP) and the three-stage turbine of low pressure (TLP).

Each of turbines moves a corresponding rotor of the compressor in rotation: THP – rotor CHP, TMP – rotor CMP, TLP – a fan-rotor.

THP consists from nozzle device (ND) and a rotor. ND it is typed from ten separate sectors. In sectors on three (in one sector two) nozzle shovels are connected among themselves to the help of the soldering. Nozzle blades hollow, are cooled by air selected for CHP, have deflectors for directing cooling air to internal walls of shovels and system of the punched apertures in walls of a profile and shelves of shovels behind which cooling air leaves on an external surface of a shovel and protects it from hot gases [13,15,17].

Rotor THP consists of the driving wheel (a disk with working blades), labyrinth a disk, shaft THP.

The working blades – cooled, consists of a shaft, a leg, a feather and a bandage shelf with combs. Air on cooling is brought to a shaft, passes on radial channels in a body of a feather of a shovel and leaves through apertures in a forward and back part of a feather of a shovel in a flowing part. In each groove of a disk it is established on two shovels. Shovels incorporate to a disk locks of "fur-tree" type [15].

Labyrinth disk and disk THP is cooled by air selected for CHP.

The turbine of average pressure consists of a rotor and the case of support of turbines with nozzle device TMP.

Rotor TMP consists of the driving wheel (a disk with working blades) and shaft TMP, connected among themselves bolts.

Working blades of rotor TMP – not cooled, incorporate to a disk locks of "fur-tree" type. The disk is cooled by air which is selected for CHP.

In the case of support of turbines external and internal covers are connected among themselves by racks which pass in empty shovels nozzle the device of the second stage of the turbine. Through blades there pass also pipelines oil and airlines of communication. In the case of support of turbines there are knots of back bearings of support of rotors of medium and high pressure [13,15].

Nozzle the shovels cast in the form of sectors on three shovels in sector, are cooled by air which is selected because of fourth step CHP.

The fan turbine consists of a rotor and stator. Stator fan turbines consists of the case and three nozzle the devices typed from separate cast sectors on five blades in sector.

Rotor of the turbine of the fan of a disk-drum-type design. Disks incorporate among themselves and to shaft of the turbine of the fan bolts.

Blades, as nozzle, and the workers who are not cooled; disks of the turbine of the fan are cooled by air which is selected for CHP. Working blades of all stages of rotor HP – bandaged, connected to disks locks of "fur-tree" type.

The target device of the turbine consists of the case of a back support, a jet nozzle of an internal contour and flower [11,12,13,15].

On the case of a back support of the turbine places of fastening of knots of a back belt of an engine mount to the plane are located.

The back knot of an engine mount is established on a power ring that is a part of an external cover of the case of a back support. In the case it is located bearing knot of a rotor of the fan. In racks which connect internal and external covers of the case, communications of a back support of a rotor of the fan are located.

The reversive device is intended for creation of return (negative) draught of the engine for the purpose of reduction of length of run of the plane at planting and the interrupted launch.

The reversive device of trellised type, ring with motionless lattices and twelve shutters which block at reversing draughts the channel of an external contour of the engine. On modes of direct draught of a shutter are established in the mobile case of the reversive device level with its internal surface which forms the channel of an external contour of the engine on a site between an external cover of an intermediate contour and a nozzle of an external contour [15].

Control system of the reversive device hydraulic, with use of a hydraulic liquid from plane hydrosystem. The system comprises: the hydromotor; the management crane; the distributor; the valve thermal; valves the return; the filter of thin clearing. Management of work of the reversive device is carried out by the control lever of a backspacing located in a cabin of pilots of the plane.

Oil system and system of prompting the engine – independent, circulating, under pressure. Giving of lubricant oil from an oil tank is carried out by a forcing step oil-unit. Three pumping out steps oil-unit pump out oil from oil cavities of bearings of rotors of the engine in a cavity of a box of drives, whence the fourth pumping out step pumps out the fulfilled oil to a lubricant tank through an air separator and fuel-oil a radiator. Cooling of the fulfilled oil occurs in fuel-oil the unit established in a fuel highway of low pressure of fuel between pumps low and a high pressure of the block of fuel pumps [15,16,17].

Prompting oil cavities of support of turbines it is carried out through a dividing cavity (a vertical rack of the intermediate case) where there is a preliminary branch of oil from an oil-air mix. Further to mix from support of turbines joins mix from support of compressors and in common go in the centrifugal prompter, whence cleared air exhaust for borders of a motor-gondola by means of active ejector, and oil merges on the channel in a cavity of an intermediate drive. The air cavity of an oil tank is prompted with a box of drives which are in turn prompted with atmosphere through the centrifugal prompter.

The fuel system and regulations (hydromechanical) provides fuel giving in the engine in the quantity caused by position of a control lever by the engine (CLE) and conditions of flight, and includes following basic units: the block of pumps; a fuel regulator; fuel-oil the unit.

System units carry out:

- Automatic dispensing of fuel at start, going up and on constant modes;
- Keeping of a constancy of the mode set CLE at change of conditions of flight (height, speed, air temperature).

The electronic control system carries out all regimes restriction under the set law of temperature of gas for TMP and restriction of frequencies of rotation of rotors high pressure and the fan.

Stop the engine by an electric command is carried out by the electromagnetic valve stop and the crane stop the engine.

Engine start – automatic. Rotating rotor HP it is carried out by the air starter established on a box of drives of the engine.

As the source of compressed air for an air starter is used auxiliary gas-turbine engine established by the plane, land sources with similar parameters of air, and also the working engine. The start program is carried out automatically by units which are a part of start system and fuel system [13,15,17].

The control system includes automatic machines of management taps for passing air (TPA) CMP and TPA CHP, which on the set modes supervise over opening - closing TPA CMP and TPA CHP.

On the engine units of system of power supply of the plane are established: a starter-generator; the air-oil heat exchanger and the oil filter in oil system of the starter-generator. On a box of drives two drives for hydropumps which are established at engine installation aboard the plane are executed. At engine installation aboard the plane on the engine elements of plane fire-prevention system - signalling devices, leading collectors of put out liquids and electric cables are established also. Gauges and the signalling devices established on the engine, give out signals about parameters of work and a condition of knots, systems and the engine as a whole. On the engine gauges and signalling devices of systems are established:

- Alarm systems about an overheat in internal oil and prompted cavities of the engine;
- Alarm systems about stall;
- Alarm systems about presence of a metal shaving in oil which is pumped out from support;
- Measurements of degree of increase of pressure of air in the compressor.

On the engine gauges and signalling devices which supervise are established:

- Work of oil system and prompting system;
- Work of fuel system;
- Work of a control system as compressors;
- Work of system of start;
- Starter-generator work;
- System work reversing draughts of the engine;
- Frequency of rotation of rotors of the fan, high and average pressure;
- Gas temperature behind the turbine of average pressure;
- Level of vibrations of rotors of the engine.

The information on a condition of knots, systems and the engine as a whole arrives on indexes by the plane, in the onboard monitoring system of the engine and in the onboard device of registration of flight data.

The onboard store established by the plane, registers corresponding parameters of work of the engine which allows to estimate and predict an engine condition on gas-dynamic to parameters, to parameters of vibration and on parameters of work of oil system and prompting system [15,16,17].

The control of a condition of a flowing part of the engine is carried out by means of the optical device through the special apertures executed in case details of the engine.

By means of the optical device it is possible to examine following elements of a flowing part of the engine:

- Working shovels of all steps CMP and CHP;
- Hot pipe with working fuel atomizers;
- Nozzle device THP;
- Workers of shovel THP, TMP and all stages TLP.

Conclusions to part 2

This part provides general information about the D-436T1/T2 turbojet two-circuit engine, as selected as the object of diagnosis. The longitudinal section of the engine is given, and it is indicated by which high effective engine performance is achieved. A brief description of the engine design is made.

PART 3

IMPROVEMENT OF DIAGNOSTICS OF GAS TURBINE ENGINES

Analysis of failures and malfunctions of gas turbine engines shows that about 50% of engine failures occur due to the destruction of parts operating in an oily environment (bearings, gears, splined joints). Oil is a carrier of information about the technical condition as a result of oil washing of wear parts. During engine operation, wear products get into the oil. In case of emergency wear of GTE friction units, the flow of wear products into the oil increases sharply both in volume and in the size of metal particles.

The simplest ways to control worn parts are: periodic control of the presence of shavings on the filter elements of the oil filter; installation and control of magnetic stoppers and chip signaling devices. Magnetic stoppers and chip detectors are installed in oil pumping pipelines, drive boxes and gearboxes. The specified control methods allow in some cases to detect the primary destruction of engine elements [16,17,18,19]].

The primary purpose of oil condition monitoring and degradation detection is to determine if the oil has deteriorated to the point where it can no longer perform its functions. The work examines various existing methods of analysis and control of the state of lubrication in the engine, their advantages from the point of view of quick equipment maintenance and the fastest possible decision-making, the designs and capabilities of oil analyzers as devices are considered. A variety of worldwide studies on the development of online oil condition monitoring and residual life prediction using particle filtering techniques and commercially available online sensors are also described. Viscosity and dielectric constant are chosen as performance parameters for modeling the degradation of lubricants. In particular, the evaluation of the lubrication efficiency and the forecast of the remaining service life of spoiled oil with data on viscosity and dielectric constant using particle filtration are provided. To demonstrate the effectiveness of the developed methodology, a simulation study was conducted based on laboratory-tested models. Oil is an important source of information for the early detection of

machine malfunctions, as is the role of testing human blood samples for disease. In modern industries, lubricants play an important role in maintaining the working condition of complex mechanisms, for example, gas turbine engines. Considerable effort has been invested in the development and research of oil diagnostic systems and forecasting of its further use. Compared to vibration-based machine condition monitoring methods, oil condition monitoring provides approximately 10 times earlier warning of machine malfunctions [10,16,17,18,19].

3.1 Methods of oil analysis and control

Currently, the method of spectral analysis of oil has found application, which allows you to estimate the concentration of wear products in oil and predict the wear of a gas turbine engine. The method is based on burning oil samples in an electric arc. At the same time, atoms of chemical elements are excited and emit photons of light. Each chemical element has its own radiation spectrum. The intensity of the glow depends on the concentration of each chemical element in the oil.

This method is characterized by high sensitivity and accuracy. With its help, it is possible to detect up to 95% of malfunctions of parts arising as a result of oil washing. The MFS-5 quantum meter, used in the diagnosis of gas turbine installations by this method, is capable of determining the content of up to 18 elements in oil, such as iron, carbon, copper, silver, chromium, nickel, aluminum, silicon, lead, tin, etc. . According to the nature of the wear products contained in the oil, the expected place of development of the malfunction and possible failure is determined [16,18].

The schematic diagram of the MFS-5 oil photospectrometer is shown in Figure. 3.1.

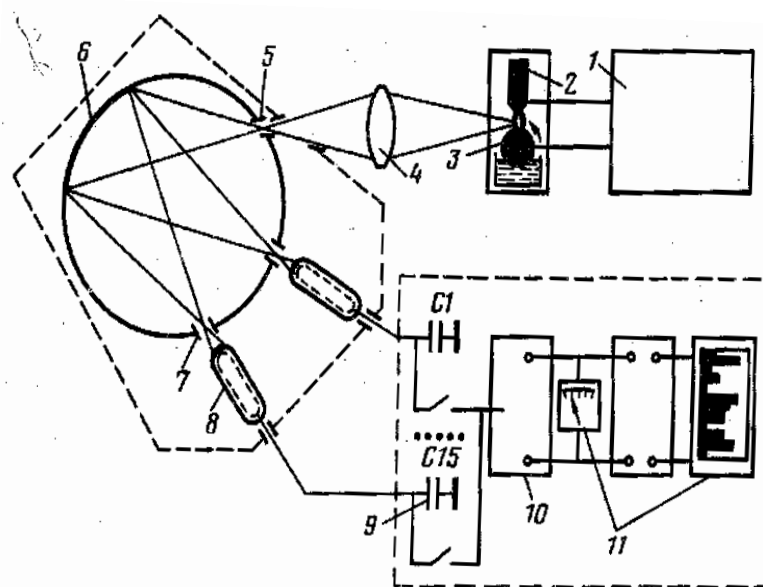

Figure 3.1 – Schematic diagram of the oil filter spectrometer: 1 – generator; 2 – upper electrode; 3 – carbon disc; 4 – lens; 5 – input slit of the spectrometer; 6 – section of a concave mirror with a diffraction grating; 7 – output slit of the spectrometer; 8 – photoelectronic multiplier; 9 – capacitor; 10 – amplifier; 11 – recording devices

The carbon disc 3, which is immersed in a bath with oil, rotates and supplies oil to the discharge gap. An electric discharge occurs between the disk and the upper electrode 2. The radiation of the discharge is directed to the input slot 5 of the device.

Dispersion of light occurs on the diffraction grating, which is made in the form of a concave mirror 6 with strokes applied to its surface. The spectrum formed by the diffraction grating characterizes the composition of the wear products contained in the oil. The output slits of spectrometer 7 separate sixteen spectral lines of elements from the spectrum. The intensity of the spectral lines is proportional to the concentration of the corresponding elements in the sample. The radiation of the selected spectral lines is directed to the photoanodes of the photoelectron multipliers 8. This leads to the emission of the electrodes on the cathode, the flow of current in the anode circuit and the accumulation of charge on the integrating capacitors 9. After the end of the process of accumulation of charges with the help of the constant current amplifier 10, successive readings are

obtained, which are proportional voltage on integrating capacitors. The duration of the analysis of one oil sample is approximately 3 minutes.

Along with the MFS-5 installation, a modern installation is used MFS-8, MFS-11 (Fig.3.2), as well as a more compact installation "Bars-3", which is an X-ray diffraction-free analyzer. The principle of operation of the Bars-3 installation is based on the disruption and registration of the characteristic radiation of chemical elements that are part of the substance being analyzed [19,20].



Figure 3.2 – MFS-11 optical emission spectrometer

The intensity of the characteristic radiation of the sample is determined depending on the concentration of elements in the oil sample under study. The greater the content of the chemical element in the oil, the higher the radiation intensity.

The MFS-11 optical emission spectrometer is a compact, reliable, modern device (Fig.3.2) for the analysis of engine and transmission oils for wear products of engine parts and other mechanisms during their operation. The spectrometer is used for diagnostics of gas turbine engines, transmissions, other mechanisms of airplanes, locomotives, gas transportation equipment, trucks, tractors, etc. This is a

new generation device that combines the advantages of the well-proven MFS-5 (MFS-7) spectrometers with the most modern technical solutions.

An important advantage of new spectrometers is the ability to register the entire spectrum of the analyzed sample, which allows, in addition to the analysis of the content of predetermined elements, to quickly detect new inclusions and impurities. The spectrometer does not require argon purging.

The optical system is built according to the Paschen-Runge scheme with a Roland circle diameter of 0,5 meters. (Fig.3.3) To ensure the spatial stability of the spectrum, all optical elements are installed on a single platform with good thermal conductivity[16,19,20].

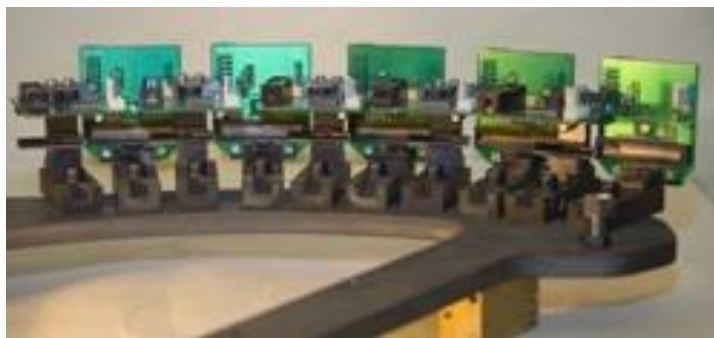

Figure 3.3 – MFS-11 optical system

Linear CCD detectors are used as radiation receivers. The original design of the detector installation without dead zones allows you to register the entire spectrum in the entire range of the device's operation. Registration of the entire spectrum, and not individual lines, as in the case of using photomultipliers, opens up practically unlimited possibilities for the analysis of different materials on one device. MFS-11 is equipped with an original tripod design that allows you to analyze various machine oils for wear products.

The speed of rotation of the disk varies depending on the viscosity of the analyzed oils. This type of diagnostics allows you to determine the mechanical components of motor, transmission oils, etc. A rotating quartz disc is used to introduce liquid oil samples into the tripod [19,20].

A compact, highly stable low-voltage spark source with digital control is used as a spectrum excitation source in the MFS-11 optical emission spectrometer.

The amplitude and shape of the discharge current, as well as the duration and frequency of discharge pulses can be adjusted over a wide range. Thanks to this, the source provides elemental analysis of a wide variety of oils, metals, alloys and other materials.

Management of all parameters of the generator from the computer provides:

- ✓ selection of optimal discharge circuit parameters and pulse frequency;
- ✓ switching of discharge modes during one exposure, it is possible to use up to 5 different modes, including burning, during one analysis;
- ✓ additional sharpening of the leading edge of the discharge pulse;
- ✓ automatic assignment of generator parameters when choosing an analytical program.

All this increases the accuracy of the analysis and expands the analytical capabilities of the spectrometer.

The registration system provides control of spectrometer nodes, its testing, measurement and processing of analytical signals. The use of the most modern element base made it possible to reduce dimensions and reduce energy consumption. Thanks to the high-speed USB interface, the entire registered spectrum (about 40,000 values) is transferred to the computer almost instantly.

The software of the WinCCD installation is a powerful program for managing and processing data in modern emission spectrometers with registration on multi-element receivers, which ensure the registration of not individual spectral lines, but the entire spectrum of the analyzed sample. WinCCD includes both tools for working with spectra in general, as well as all tools for obtaining and processing analytical results developed earlier. Wide functionality combined with versatility and simplicity allow for both qualitative and accurate quantitative analysis of samples. The program contains a variety of tools for the development of analytical techniques using various methods of spectroanalytical data processing. The program contains large databases of spectral lines of various elements, as well as spectra of various metals and alloys [16,20].

The WinCCD program allows:

- ✓ record the spectrum of the analyzed sample in the entire spectrometer operating range;
- ✓ carry out qualitative analysis of unknown samples;
- ✓ consider in detail the outline of a separate analytical line;
- ✓ choose any analytical lines or analytical pairs for quantitative analysis, taking into account the recommendations of standards and own experience;
- ✓ keep track of the influence of neighboring lines and the background in the vicinity of the selected analytical line;
- ✓ build grading graphs on a linear or logarithmic scale, taking into account the mutual effects of elements, taking into account dilution of the basis, etc.

Currently, the operational analysis of the performance of oils and working fluids has become the main tool for monitoring the condition of oil-filled equipment. This happened because the analysis of oils makes it possible to indicate the internal defect of the technique at an earlier stage of its development compared to other methods of non-destructive testing. And, in addition, the operational analysis of oils is the main element of preventive and proactive maintenance systems of oil-filled equipment, namely, internal combustion engines, transmissions, hydraulic systems, gearboxes, turbines, etc [16,17,21].

As an example, consider the design and capabilities of the MicroLab 40 oil analyzer from Spectro Scientific (Fig. 3.4).



Figure 3.4 – MicroLab 40 comprehensive oil analyzer

All of the hardware inside the OSA analyzers and the software have been built in accordance with published ASTM standards. This means that every measurement made on the OSA instrument meets ASTM's own unique standards (D7417-10 "Standard Test Method for the Analysis of Operational Lubricants Using a Four-Component Integrated Tester") [19,21].

The world's leading manufacturers of equipment and machinery, such as Caterpillar Inc and Peterbilt Motors Company, require that their machinery be serviced in accordance with ASTM standards. This is one of the many reasons why service providers use them for diagnostic analyzes in OSA equipment service centers.

Complex analyzers of the OSA series fully comply with the ASTM standard - the standard test method for analysis of used lubricants involves the use of an integrated device that includes four or fewer measuring units (atomic emission spectrometer, infrared spectrometer, viscometer and laser particle counter)- Standard Test Method for Analysis of In -Service Lubricants Using Particular Four-Part Integrated Tester (Atomic Emission Spectroscopy, Infrared Spectroscopy, Viscosity, and Laser Particle Counter).

The MicroLab40 integrated devices include the measuring units listed below. Each block functions independently and can be disabled or activated by the user depending on the selected test method [16,21]:

1. The optical emission spectrometer unit is designed to measure the content of elements in an oil sample. The basic configuration of the spectrometer includes 10 defined elements: iron, chromium, lead, copper, tin, aluminum, molybdenum, silicon, sodium, potassium. The advanced configuration of the spectrometer, in addition to the basic one, includes: nickel, titanium, manganese, vanadium, boron, magnesium, calcium, barium, phosphorus, zinc – a total of 20 elements. The ASTM commission (Research Report: RR11532.07) determined that the error of the analysis does not exceed the permissible errors according to the standards: ASTM D6595-00 - Test Method for Determination of Wear Metals and Contaminants in Used Lubricating Oils or Used Hydraulic Fluids by Rotating Disc

Electrode Atomic Emission Spectrometry; and ASTM D5185-09 – Standard Test Method for Determination of Additive Elements, Wear Metals, and Contaminants in Used Lubricating Oils and Determination of Selected Elements in Base Oils by Inductively Coupled Plasma Atomic Emission Spectrometry (ICP-AES).

2. The infrared spectrometer block is designed to determine the physicochemical parameters of oil – water content – range – 0.1÷3% – error ±0.2%, – glycol admixture – range 0.1÷2% – error ±0.2%, – soot — range 0.1÷4% – error ±0.2%, - fuel impurity (gasoline) — range 0÷15% — error ±0.2%, — degree of oxidation — range 0.1÷50abs — error ±0.2 Abs, — degree of nitration — range 0.1 ÷35abs – error ±0.2 Abs. All defined parameters correspond to the ASTM E2412 method – Practice for Condition Monitoring of In-Service Lubricants by Trend Analysis Using Fourier Transform Infrared (FT-IR) Spectrometry.

3. The viscometer unit is intended for measuring the kinematic viscosity of an oil sample at temperatures of 40°C and 100°C and calculating the viscosity index based on the obtained data. Viscosity 40°C – range 30÷320 cSt – error ± 2,5 cSt. Viscosity 100°C – range 5÷25 cSt – error ± 1,0 cSt. The viscometer block fully complies with the ASTM D445 method – Test Method for Kinematic Viscosity of Transparent and Opaque Liquids. The algorithm for calculating the viscosity index fully complies with the ASTM D2270 method – Practical recommendations for calculating the viscosity index from viscosity data at 40°C and 100°C [19,21].

4. The laser particle counter unit is designed to determine the number and size of particles of mechanical inclusions in liquids. It has 8 sizing channels: 4, 6, 10, 14, 21, 25, 38 and 70 micrometers. It fully meets the requirements of ISO 4406 - Determination of the coding of mechanical contamination in fluids of hydraulic drives - Hydraulic Fluid Power Solid Contaminations Code and has a calibration scale in accordance with ISO 11171:1999.

MicroLab 40 is a fully automated complex and consists of four independent devices housed in one housing. The analyzer is designed for the analysis of oil

samples and provides full diagnostics of internal combustion engines, stationary and mobile hydraulics, turbines, gearboxes and transmissions, industrial gearboxes and other lubricated units and mechanisms. The analyzer allows you to get complex analytical results when diagnosing the engine, generator, gearbox, hydraulics, power steering, transmission and other units and units. MicroLab enables any company engaged in maintenance of equipment to analyze the overall performance of the equipment based on the results of physical and chemical analysis of oil samples. The device provides results in less than 15 minutes, allowing the mechanic to take immediate maintenance action.

The devices of the MicroLab series were designed to receive a diagnostic report immediately after the sample analysis and have a built-in intelligent system of expert evaluation of the obtained results.

Analytical data is compared with the standard database and sample data (mileage, type of oil, type of equipment, etc.), after which a report on the condition of the equipment and oil is automatically created and recommendations for maintenance are given.

The MicroLab 40 is an ideal diagnostic tool that allows companies to detect problems with the reliability of mechanisms before they become critical and lead to failure. The ability to track the life of the oil allows you to determine the time of its potential aging, which allows you to safely extend the interval of its use, allowing you to save money on oil consumption, waste oil disposal and labor costs associated with unnecessary equipment maintenance. The analyzer combines several measuring modules, automated jet pneumatic automation and interactive software. It provides common users with the ability to obtain analytical results along with diagnostic interpretation [21].

MicroLab 40 is equipped with an infrared spectrometer that measures 6 key oil parameters:

- Degree of oil degradation: oxidation, nitration, alkalinity;
- Oil contamination: soot, water, antifreeze, fuel.

The obtained values of chemical properties make it possible to calculate the final service life of the oil.

Elemental composition

The optical emission spectrometer included in MicroLab measures:

- the concentration of wear metals that enter the oil from machine parts;
- concentration of elements from the additive package;
- concentration of elements of external pollution.

Elemental analysis

Elemental analysis is the basis of any oil analysis technology and is designed to quantify metal particles caused by mechanical wear, as well as identify other impurities and additives. This analysis provides information about the condition of equipment and oil. An extended list of elements registered by the analyzer are listed above.

The determined parameters of the elemental composition of the oil allow us to draw a conclusion about the type and place of wear; calculate the resource of the lubricant, determine the source of external pollution, draw a conclusion about the effectiveness of the lubricant and choose the best type of oil.

MicroLab uses optical emission spectroscopy (OES) to quantify the composition of mechanical impurities, oil additives or foreign particles.

The basic principle of OES is that each element has a unique atomic structure. When an atom has sufficient excitation energy, it forms a discrete spectrum of radiation waves of different lengths (or colors) depending on its atomic structure. Since no element has the same structure of emitted waves, the discrete spectrum is a kind of fingerprint that can be used to identify the elements present in the sample (Fig.3.5). Accordingly, the intensity of the emitted light can be correlated with the concentration of this element in the sample.

An optical emission spectrometer consists of three parts: (1) an excitation source, (2) an optical system, and (3) a readout system [21].

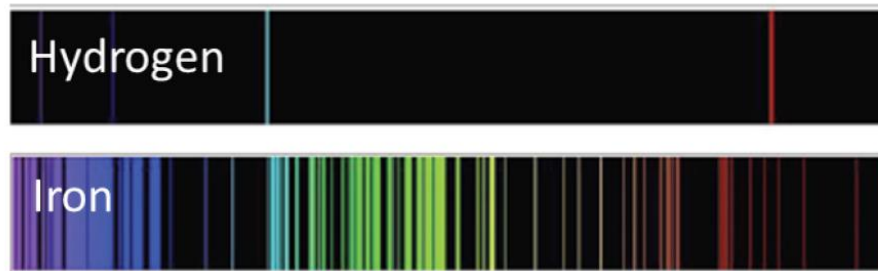

Figure 3.5– Spectra of optical radiation of hydrogen and iron

There are several most popular methods of elemental analysis of oil, which mainly differ in the source of excitation of the sample: spectroscopy with inductively coupled plasma, spectroscopy using an electric arc electrode, spectroscopy using rotating disk electrodes, spark spectroscopy.

In the OES MicroLab, the source of excitation consists of a spark stand, two electrodes and a high-voltage power source. High voltage from a pulsed power supply with computer control is applied to the upper and lower electrodes of the spark stand to generate an electric spark and create a plasma (Fig.3.6÷3.7).

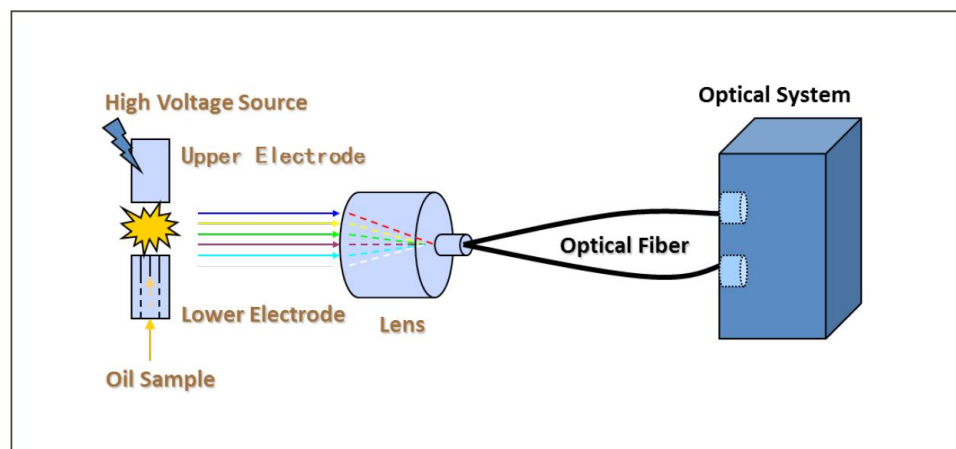

Figure 3.6 – Scheme of the UES MicroLab spectrometer

The oil sample is fed from the bottom up through the coaxial opening of the lower electrode into the plasma zone, where it is heated, vaporized and atomized. The atoms of the oil elements are excited by collision with charged particles in the plasma. Some atomic elements are in an ionized state, and the ions formed are also excited. When these excited atomic or ionic elements return to their ground states, they emit the light that characterizes an emitting element. The emitted light is

collected using a lens and delivered by an optical fiber to an optical spectrometer, where data of the radiation spectrum is collected (Fig.3.7).

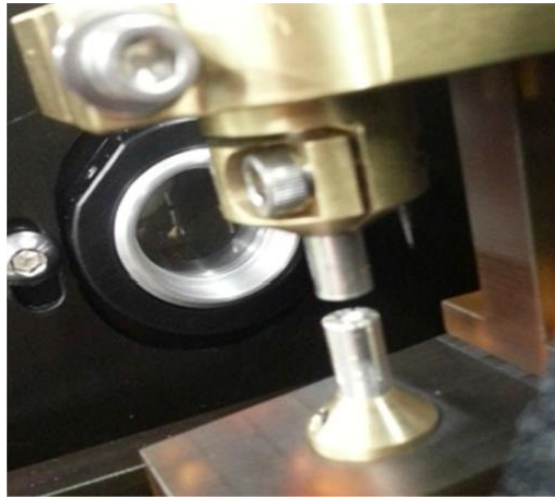

Figure 3.7 – Image of the MicroLab 40 spark stand

The figure below shows a typical emission spectrum (in red) of a sample of oil used by the consumer, and for comparison the emission spectrum of a white mineral oil that does not contain any metal wear elements is shown (Fig.3.8) [21].

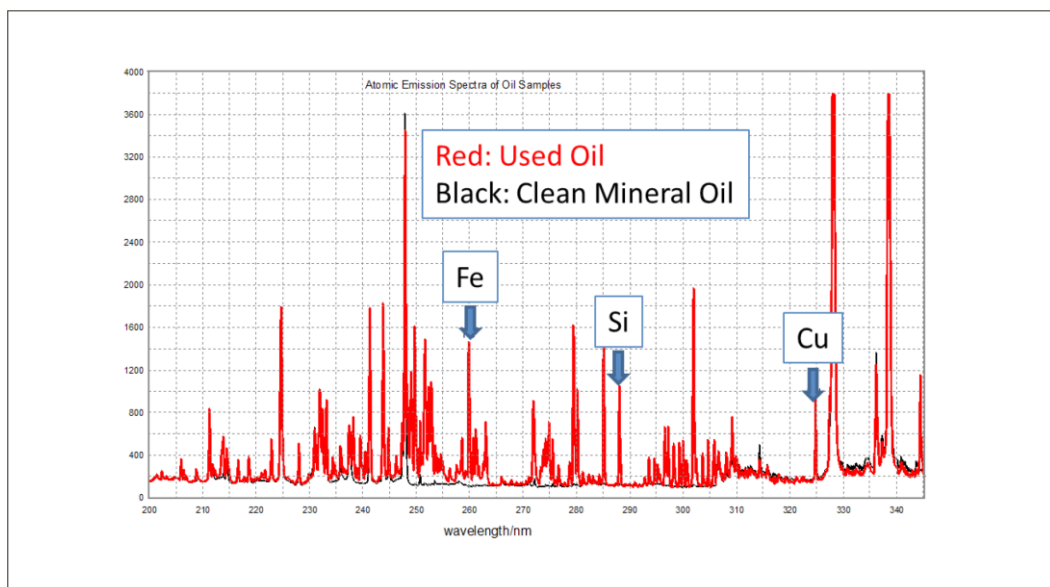

Figure 3.8 – Representative emission spectra taken from two oil samples: the spectrum in red is from the consumer oil sample, and the spectrum in black is white mineral oil, shown here for comparison

The emission lines (or peaks) for iron (Fe), silicon (Si), and copper (Cu) are identified based on their wavelengths. The concentration (in parts per million or ppm) of each element is determined by measuring the peak area of each element

and comparing it with the peak area of standard samples obtained during instrument calibration.

Several parameters of the OES system, such as spark frequency, voltage, electrode gap, and oil flow rate, can affect the nature of the plasma and therefore affect the accuracy of the sample concentration measurements. These parameters are optimized during production, and then the OES is calibrated with a set of standard samples with known element concentrations. Calibration coefficients for each of the elements are stored in the computer and are used later to calculate element concentrations for unknown customer samples [17,19,21].

Comparison with other methods

MicroLab usually correlates well with other OES methods, providing similar diagnostic information. The working principle is the same for all methods of optical emission; however, there may be some differences due to matrix, plasma temperature or particle size. The MicroLab module is a specialized fixed-electrode spark spectrometer specially selected for the application. The temperature of the OES MicroLab plasma is the lowest of those commonly used in used oil analysis:

- ICP: approximately 6000 to 8000K
- RDE: approximately 5000 to 7000K
- OES MicroLab: approximately 3000 to 5000 K

In oil diagnostic laboratories, ICP analysis is usually a melt-and-evaporate approach. The oil sample is diluted with kerosene and sprayed in a special chamber to obtain an aerosol, which is introduced into the plasma to obtain the radiation spectrum. Excellent accuracy and convergence can be achieved at particle sizes of less than 5 μm . To analyze large particles, acid ashing must be used, which increases the time and cost of the analysis. Advantages of ICP are reduction of matrix effects due to sample dilution, analysis of larger particles with acid ashing, and excellent analytical performance. The main disadvantages of ICP are the cost and the need for sample preparation.

Figure 3.9 shows the results of MicroLab OES tests in comparison with the results of OES-ICP laboratory studies for standard elements in mineral oil, as well

as for a series of motor oils that were operated with an increased load in machinery.

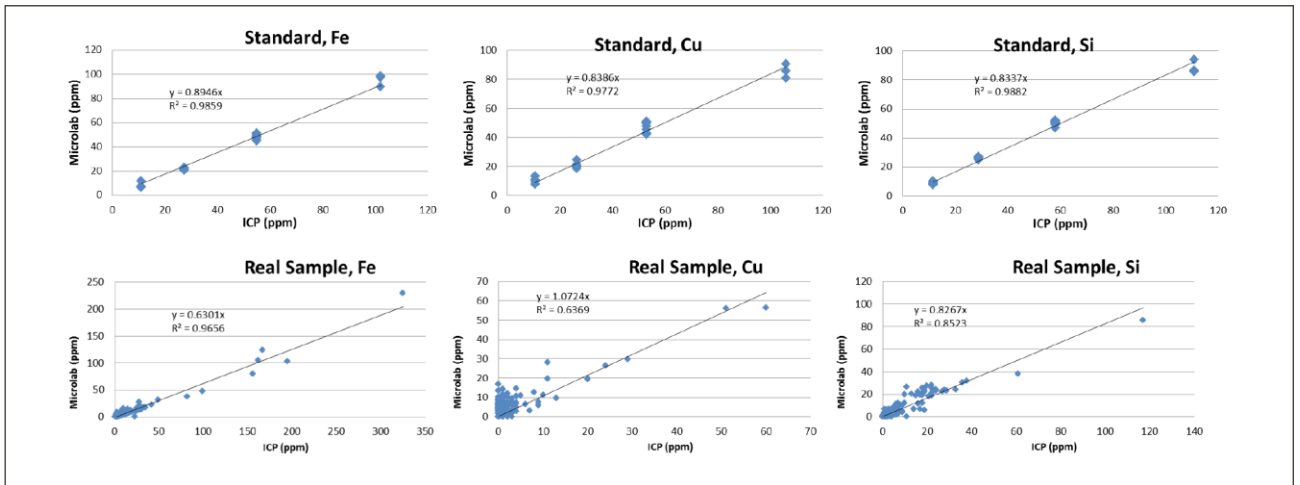

Figure 3.9 – MicroLab results comparable to Lab ICP-OES for standard elements and several real field oil samples

As can be seen, the results of the MicroLab are slightly lower than those of the ICP, but since this trend persists both in the standard samples and in the oil samples during the period of operation, the obtained results remain reliable. Elemental standards also show excellent correlation over the calibration range. The main differences with ICP are probably related to matrix effects in real samples. Typically, the ICP dilution factor is about 1, so any matrix effect is minimized.

Figure 5 compares MicroLab results for various real samples with the more similar SpctrOil RE-OES method. The results obtained in MicroLab are slightly lower in magnitude, probably due to the difference in plasma temperature, but it is still reliable diagnostic information compared to this technique [21].

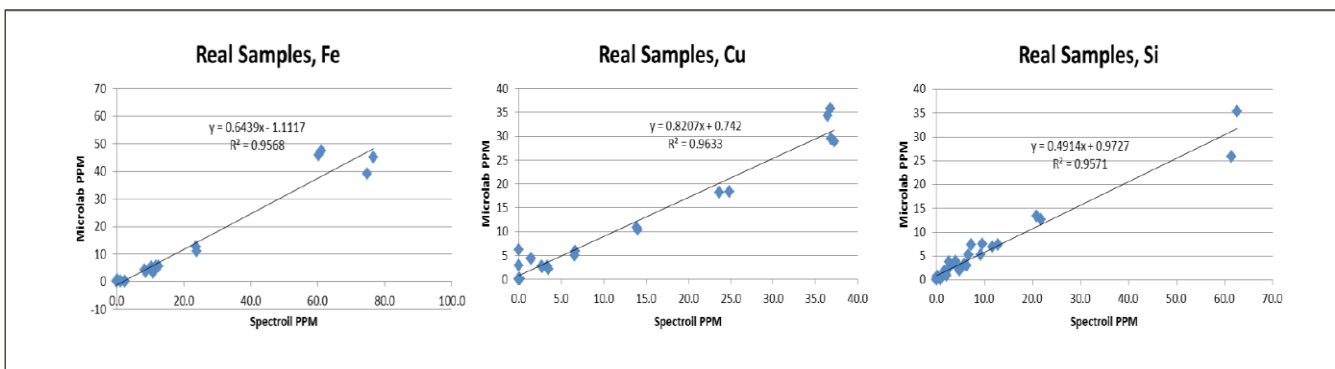

Figure 3.10 – MicroLab results compared to SpctrOil RDE-OES for several real in-service oil samples.

It can be concluded that MicroLab is designed for routine oil analysis and gives results that, in combination with other measurement methods, allow you to form a reliable picture of what is happening with the components. The results may differ slightly from those obtained with RE or ICP, but they will be sufficient to diagnose problems with equipment wear and with the effectiveness of the lubricant. The main advantage is the ability to analyze the composition of particles up to 18 micrometers in size, which means early diagnosis of abnormal wear.

Principle of operation

In Microlab, the IR module uses the method of mass spectrometric analysis with the help of IR filters, which allow the differentiation and quantification of the components in the oil sample. The module uses a proprietary set of optical bandpass filters mounted on the spectrometer to measure the IR absorbed by the oil sample at each specific filter, as shown in Figure 3.11. The amount of light absorbed is proportional to the concentration of the component(s) in the oil sample. The sample is introduced into the sample cell of the MicroLab IR module, and the spectrometer is returned to each of the 15 filters where a scan is performed to collect absorbance data.

The mid-infrared radiation range of $800\div4000\text{ cm}^{-1}$ is the most interesting and productive area for routine oil analysis. Using built-in calibrations for various parameters, MicroLab analyzes the collected IR spectrum and provides quantitative data [21].

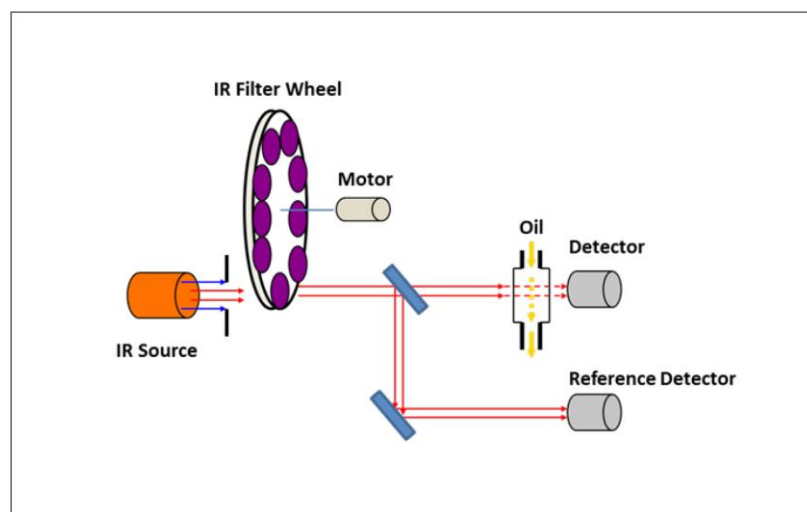

Figure 3.11 – MicroLab IR module

Oxidation and nitration products appear as peaks in the IR spectrum in the range between 1600 and 1800 cm^{-1} . Since there are no absolute reference standards for oxidation and nitration, the results are always compared to the results exhibited by new and in-service oil. For example, if the nitration peak with an indicator 1650 cm^{-1} becomes significantly more intense in motor oil samples over a certain period of time, then this indicates the nitration process, which may indicate an incorrect air-fuel ratio. The total alkalinity can be controlled by the depletion of the additive in the oil, which manifests itself as a decrease in the absorption peaks in the range from 1000 to 1900 cm^{-1} . Water, which is dissolved in oil, shows a characteristic absorption peak in the range between 3200 and 3800 cm^{-1} .

Comparison with other methods

Infrared technology is a commonly accepted tool for oil analysis, and is mainly used for laboratory and field studies. The two main methods are ASTM E2412, which uses the standard practice of Fourier transform infrared spectroscopy, and ASTM D7889, which describes the capabilities of a portable Fourier-IR spectroradiometer. In addition, specific diagnostic methods for oxidation (D7414) and nitration (D7624) were standardized. Each ASTM method may be specific to a particular IR spectrometer, but the results of different methods may be similar (parameters, units of measurement, etc.). The MicroLab IR spectrometer uses a special design to measure oil analysis parameters that match or correlate well with all existing laboratory methods [19,21].

Titration methods are used as a criterion for analyzing the content of alkaline components and water in oil. Potentiometric titration is an acceptable method for total alkalinity analysis per ASTM D2896 or ASTM D4739. These titration methods are intended only for laboratories and use different solvents and reagents. MicroLab uses a chemometric algorithm that allows you to determine the total alkaline number based on matching the original IR spectrum with laboratory methods. The classic method for determining water content is Karl Fischer titration ASTM D6304. As shown in Figure 3.12, the MicroLab water content measurement method correlates well with the Karl Fischer method [21].

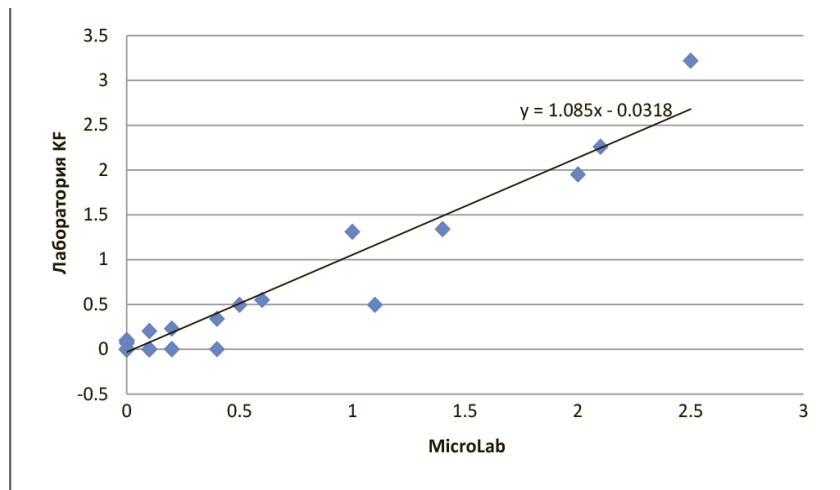

Figure 3.12 – Ratio of water (%) according to the MicroLab method and by Karl Fischer

Viscosity

Viscosity is an important criterion in oil analysis, as it determines the bearing capacity of the oil film in the contact zone, as well as how easily it circulates.

Kinematic viscosity is defined as flow resistance under the action of gravity (constant force). MicroLab uses a two-temperature viscometer module to measure sample viscosity at 40°C and 100°C. Based on the received data, the viscosity index is automatically calculated.

The two-temperature viscometer, located in MicroLab, works according to the principle of flow samples under constant pressure (Fig. 3.13). The oil sample is pumped into two thermostatically controlled chambers, one with a temperature set at 100°C and the other at 40°C. After the sample temperature reaches equilibrium with the chamber temperature, the sample is forced by compressed air at constant pressure through a precision hole in the bottom of the chamber. The expiration time of a fixed amount of sample is directly related to its viscosity. Therefore, the viscosity can be accurately determined based on the end time. This approach to viscosity measurement is ideal for analyzing contaminated samples and samples with a high content of mechanical impurities.

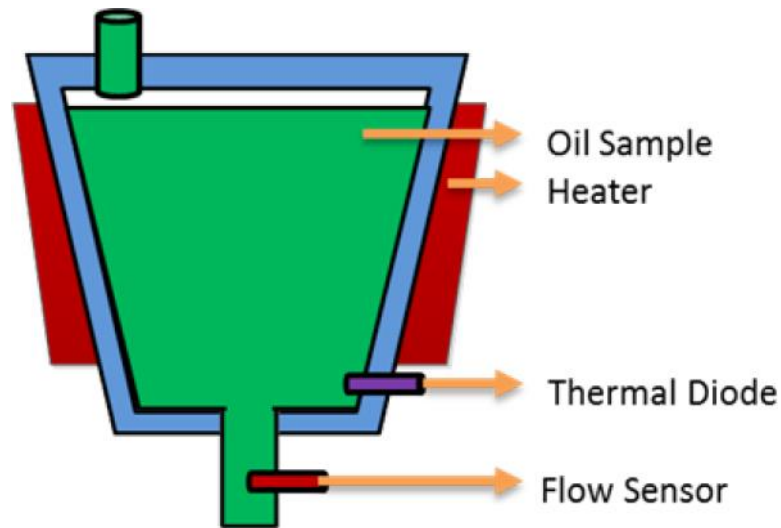

Figure 3.13– Viscometer module

Industrial cleanliness

Only the MicroLab 40 model is equipped with a built-in particle counter, which determines the size of particles and their number in accordance with the ISO 4406 standard. The triple code of industrial purity is the most important criterion for the quality and applicability of hydraulic oils. In addition, it plays an important role in the diagnosis of almost all types of oils, as it allows you to determine abnormal wear based on the presence of large particles in the oil sample.

The analyzer uses a commercially available LED laser with a light detector, as shown in Figure 3.14. The liquid passes through the measuring cell of the sensor. There is a light beam on one side of the measuring cell, and a photodetector on the other side. If there are particles in the sample, a beam of light falls on them, and as a result, the shadow of the particle will appear on the photodetector. The surface of the shadow causes a jump-like change in voltage in the photodetector and determines the size of the particle passing through the sensor cell. The particle counter converts the number of shadows on the photodetector into the number of particles in the liquid. In addition, the particle sizes are divided into different groups depending on the size. Particle measurement results are mapped to purity class standards such as ISO 4406 and SAE 4059. MicroLab correlates to the full range of ISO 4405 (0 to 25) and SAE 4059 frequency codes [17,21].

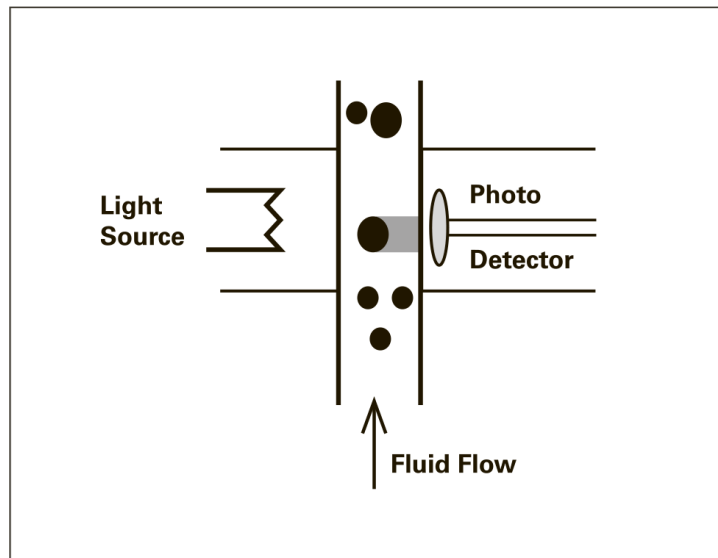

Figure 3.14 – LED block of the particle counter

The specific application and type of particles often determine what is the best particle counting method for an analysis. The three most commonly used particle counting techniques are light blocking (the method used by MicroLab), pore plugging, and direct imaging. Particle counters using the light-blocking method are widely used in many fields and are traditional in-service oil diagnostic tools. Particle counters based on the pore plugging method pass an oil sample through a fine mesh substrate. A constant flow or pressure pushes the sample through the grid, and the change in flow or pressure is measured as particles accumulate on the grid. Direct imaging-based particle counters such as Lasernet Fines (LNF) are equipped with a solid-state laser with an array of LEDs that count particles and classify them according to size and shape.

3.2 Improvement diagnosis online industrial lubrication oil and quality condition monitoring

3.2.1 Background and Motivation

The goal of most studies is to monitor the oil degradation process in real time to provide early warning of machine failure, extend lubricant life, reduce oil change frequency, and most importantly, optimize maintenance, thereby reducing maintenance costs. . According to the current industry standard, there are 3 levels

of oil analysis. Level 3 – external oil analysis. For Level 3, lubricant samples are collected and sent to remote labs for analysis and advice on proper maintenance. The delay in sampling and analysis ranges from a few weeks to a month, making it impossible to determine the actual condition of the lubricant. Level 2 is an on-site oil analysis using a portable test kit, while level 1 is an online oil analysis. Test kits are usually portable and have limited capabilities. For real-time oil analysis, information about the condition of the oil is collected by sensors embedded in the oil circulation system and transmitted to remote diagnostic centers. The collected data is analyzed using specially developed algorithms, and the result and suggestions for proper maintenance are presented in real time. At present, level 3 external oil analysis is mainly used. Oil samples are taken and sent to oil analysis laboratories to obtain information on the condition of the oil. The problem of operational control of functional failures of lubricants remains unresolved. The purpose of online oil monitoring and degradation detection is to determine if the oil has degraded to the point where it no longer performs its protective function and to provide early warning of the possibility of a complete failure in real time. The ability to monitor oil condition online will allow you to better predict the remaining life, which will lead to a significant optimization of the maintenance schedule and a reduction in the number of maintenance operations. Unexpected repairs to a gearbox or transmission often come with big bills. As you understand, if there are many unexpected breakdowns, financial losses will be significant. The introduction of online oil condition monitoring will also reduce unnecessary oil change costs, which can be close to maximum, and the number of unnecessary or unscheduled oil changes will be significantly reduced. The main function of a lubricant is to create a continuous film layer between relatively moving surfaces to reduce friction and prevent wear and thus prevent mating parts from seizing. A secondary function is cooling of the working parts, protection of metal surfaces from corrosion, flushing or preventing the penetration of contaminants, as well as the relative absence of deposits on the binder component. In a lubricated system, a change in the physical, chemical, electrical (magnetic) and optical properties of the

lubricant changes the characteristics of the lubricant and leads to a deterioration in its protective properties. The main causes of lubricant deterioration are oxidation, particulate contamination and water intrusion. These three reasons are identified in the work as the main characteristics of lubricant degradation. Parameters that describe the characteristics of a lubricant or the level of degradation are called performance parameters. These parameters include viscosity, water content, total acid number (TAN), total base number (TBN), particle number, pH value, etc. Each performance parameter can be measured using specific measurement methods. For example, for water content, it measures the percentage of water contamination of the lubricant. This performance parameter is necessary and critical for the gearbox, hydraulic system, engine, compressor and turbine. The water content can be measured using a capacity sensor, a viscosity sensor, and a water in oil sensor [10,11,13,17,19].

To find a suitable solution for online lube oil condition monitoring and Remaining Life (RUL) prediction, a comprehensive review of existing oil condition monitoring methods is required. Over the years, scientists and experts have developed sensors and systems to monitor one or more operating parameters of a lubricating oil in order to effectively monitor the condition of the oil. These sensors and systems can be divided into four categories including electrical (magnetic), physical, chemical and optical methods. For example, the most effective electrical method for monitoring the condition of an oil is to determine the change in the dielectric constant of the lubricating oil. According to recent research, changes in capacitance or permittivity can be used to control oxidation, water contamination, and the concentration of wear particles. On the other hand, for physical methods, viscosity is most often discussed.

Lubricating oil oxidation, water contamination, particle concentration and some other changes in properties have a certain effect on the viscosity of the oil. Therefore, viscosity measurement is considered an objective means of detecting oil degradation. The ultimate goal of all of the above systems is online monitoring of

the condition of the lubricating oil and predicting the residual life of engines, machines, mechanisms, etc.

The relationship among the basic degradation features, performance parameters, and available oil condition sensors is shown in Figure 3.15.

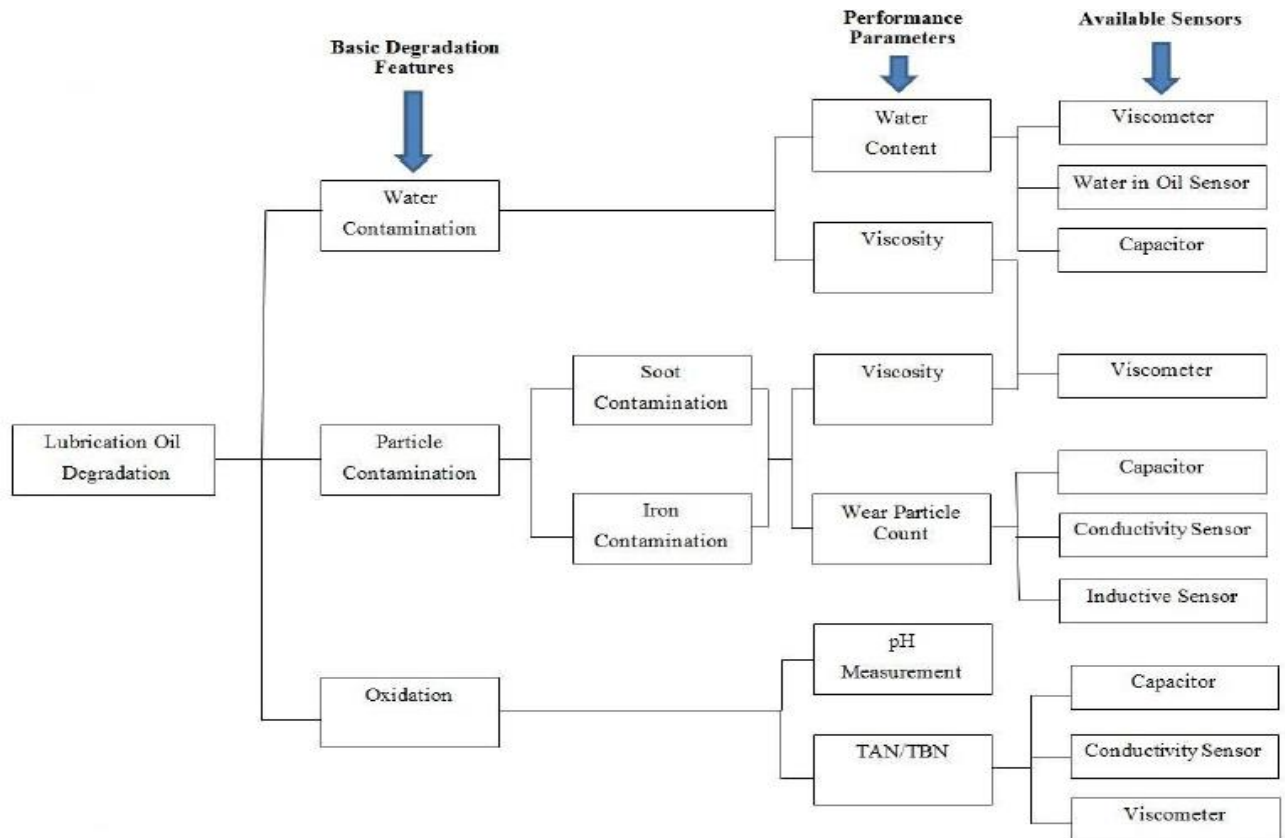

Figure 3.15– The relationship among the basic degradation features, performance parameters, and available oil condition sensors

It should be noted that most sensor systems are only capable of autonomous monitoring, in which oil samples are taken from the equipment by specialists and sent to laboratories for analysis of the condition of the oil. Therefore, the actual condition of the lubricating oil cannot be determined online due to sampling and analysis delay methods. Two of the most efficient online lube oil sensors, a kinematic viscometer and a dielectric constant sensor, were selected to develop online lube oil condition monitoring. As a result, we have a tool for predicting the remaining useful life. Kinematic viscosity is the absolute viscosity in relation to the

density of the fluid, while dielectric constant is the relative dielectric constant between lubricating oil and air.

The purpose of this paper is to present the development of a method for online monitoring of lubricating oil condition and residual life prediction based on a particle filtering algorithm and commercially available online sensors. This method was developed by integrating physical models of lube oil degradation with a particle filtering algorithm. Physical models were used to simulate the process of lubricating oil deterioration due to the main signs of deterioration in terms of kinematic viscosity and dielectric constant. Two simulation case studies, which were based on laboratory-validated models, were used to demonstrate the effectiveness of the method. Table 1.1 shows performance parameters for various applications and their reference values for lube oil degradation [16÷19].

Table 3.1 – Performance parameters, applications and their benchmark for lubrication oil degradation.

Performance Parameters	Measurement Function	Unit	Benchmark of Degradation	Applications					Available Measurement Approach
				Gear box	Hydraulic system	Engine	Compressor	Turbine	
Viscosity (40 °C)	Contamination of lubricant by some other oil, oxidation	Cst (mm ² /s)	≥ 55	yes	yes	yes	yes	yes	Kinetic Viscometer
≤ 50									
Viscosity (100 °C)			≥ 10						Micro-acoustic Viscometer
			≤ 8						
Water Content	Presence of water	%	≤ 2	yes	yes	yes	yes	yes	Capacitance sensor (Dielectric constant)
									Kinetic Viscometer
									Water in oil sensor
TAN/TBN	Acidity/alkalinity of lubricant (oxidation level)	mgKOH/gm	≥ 0.6	yes	yes	yes	yes	yes	Capacitance sensor (Dielectric constant)
			≤ 0.05						
									Kinetic Viscometer
									Conductivity Sensor
Flash point	Presence of dissolved solvents or gases in the lubricant	°C	≥ 220 ≤ 140	no	yes	yes	no	no	Thermometer
Wear Particle Count	Wear particles in parts per million	ppm	≤ 40	yes	yes	yes	yes	yes	Capacitance sensor (Dielectric constant), Kinetic Viscometer, Conductivity Sensor, Inductive Sensor
Particle Counting	Detect number of particles for sample size of 100cc	mg/L	≤ 200	no	yes	no	no	yes	

Also in the work, the particle filtering algorithm is used as a RUL prediction tool. An efficient and accurate oil condition assessment tool will help reduce equipment downtime when monitoring oil condition. The online RUL assessment includes two steps: condition assessment and RUL prediction. First, in the state estimation stage, although there are many state estimation methods, Kalman filter and particle filter are the most used. However, the Kalman filter requires many assumptions such as:

- 1) Gaussian process noise with zero mean;
- 2) Gaussian observation noise with zero mean;
- 3) Gaussian Posterior Probability Density Function (PDF), etc.

Since the nonlinear Kalman filter is based on the linearization method, any of the linearization methods (local or statistical linearization) will not work as the system nonlinearity increases, according to the layered growth by the Frank-van der Merwe mechanism. Secondly, in the RUL estimation step, particle filtering can process statistical prediction data, unlike other methods (parameter estimation). As a result, the particle filtering algorithm provides feasible solutions for a wide range of RUL prediction applications. A particle filtering algorithm integrated with oil degradation physics models will serve as the basis for the development of practical tools for accurate RUL prediction for lube oil.

3.2.2 Principles of Lubrication Oil Monitoring Techniques

To understand the principles of lube oil monitoring methods, it is necessary to consider the 3 main signs of lube oil degradation. The principles of lube oil monitoring are to monitor, directly or indirectly, the main signs of lubricant degradation using various measurement methods. The main signs of degradation include oil oxidation, water contamination and particulate contamination. Changes in these characteristics can be detected by a set of oil operation parameters.

Water contamination and its effect on lube oil performance

According to *Kittiwake Developments*, the source of water pollution may include the following]:

1) Leaks from oil coolers, aftercoolers and steam heaters, atmospheric moisture condensation.

2) Crankcase gases from the combustion chamber of the engine or after the annular compressor packs.

3) Leaks through tank vents (especially those exposed to the weather).

4) The coolant jacket is leaking through cracks or seals.

5) Contamination from top-up oil (especially in systems with low water resistance).

6) Water is a normal product of combustion in gasoline engines and the normal expansion and contraction of air in the sump causes water to condense out of the air.

7) Lip seals around rotating shafts may allow water to enter.

When operating in high speed and temperature, the oil and water mixture will form an emulsion which prevents the oil from forming an effective lubrication film between the contact components.

The water contamination can have the following influence upon oil degradation:

1) Normally, as the lubrication oil ages, the viscosity changes;

2) Water can displace the oil at contacting surfaces;

3) Water is an important contaminant in many lubricant oil systems because of its potential to cause failure via a number of mechanisms;

4) Water contamination within lubricating/lube oil storage tanks can lead to microbiological growth;

5) Water contamination of motor oils during storage and use in low-temperature conditions cause formation of deposits. As an example, in terms of permittivity, the capacitance of oil is normally between 2 to 3 while that of water is around 80. The mixture's permittivity can be expressed as:

$$\epsilon_{r,m} = (1 - f)\epsilon_{r,o} + f\epsilon_{r,w}$$

where subscripts 'm', 'o', and 'w' are the (relative) permittivity of the mixture, oil, and water, respectively, and f is the water fraction by volume. One can see that

small fractions of water would yield comparatively large changes in the total (effective) permittivity of the mixture as stated B. Jakoby, Michiel J. Vellekoop [24].

3.2.3 Oxidization and its impact on lubrication oil performance

Oils consist of long-chain oxidizable hydrocarbons. In an operating engine they are exposed to high temperatures, and this makes them more vulnerable to attack from free radicals. This means that hydroxyl groups may be introduced at random locations along the long-chain oil molecule. Hydroxyl groups damage the lubricating properties of the oils. So to prevent this happening antioxidants are added which scavenge any radicals before they can do damage to the oil. Nevertheless, some oxidation does always take place, and it appears that as a consequence colloidal carbon is formed giving rise to black coloration and solid deposits.

3.2.4 Particle contamination and its impact on oil performance

The lubrication oil performance stay stable if the oil temperature is maintained within the manufacture recommended range. In case it is not operating in the required condition, the oil deterioration starts and it reflects the degradation of lubricating oil. As a rule, an increase in temperature doubles the rate of oxidation, as well as the formation of oxidation products. Initially, these oxidation particles are soft and sticky products. When these particles come into contact with high temperature zones, it results in the formation of hard and abrasive particles. They, when in contact with the components, cause the formation of wear particles, which leads to a further decrease in the performance of the system. Therefore, to control wear and for increased performance, viscosity and contaminants (insoluble) are the contributing performance parameters as reported by Sharma and Gandhi [66]. During operation of a lubricated system, wear particles are generated. These particles can clog the filter, which may even rupture the filter and thus causing

contamination level rise to an alarming level, with possibility of reduced performance or a catastrophic failure. In addition, these can block oil holes, causing the oil starvation at the mating contact and it may even lead its seizure, causing a catastrophic failure. The high contamination level (generated, and oxidation and gummy products), particularly in, lubricated systems causes their improper operation due to malfunctioning of the valves. This may also cause internal leakage in the system and if not taken care, lead to external leakage. Particle counting can be used to determine the level present in the system.

3.2.5 Electrical (Magnetic) Techniques

Several studies have been reported using specially designed capacitors to measure the change in dielectric constant of a target lubricating oil in order to monitor oil degradation. In 2005, Joel Schmitgal, S. Moyer proved [25] that a capacitive sensor is capable of detecting lube oil oxidation, water contamination, and wear particle contamination Raadnui and Kleesuwan [26] used a capacitive grid sensor (Fig. 3.16) to measure dielectric constant with artificial oil contamination, and then used a statistical method to assess the importance and interaction of performance parameters. The capacitance of the sensor can be expressed as follows [25,26]:

$$C=(\varepsilon_0\varepsilon_vA)/\sigma.$$

where ε_0 – is the dielectric constant in the vacuum; ε_v is the dielectric constant of the oil between two poles;

A – is the available area of poles;

σ – is the distance between two poles;

For a fixed sensor, ε_0 , A and σ constant, the capacitance of the sensors is determined by while the voltage is loaded between the emission pole and the detecting circuit is proportional to the capacitance of the sensor.

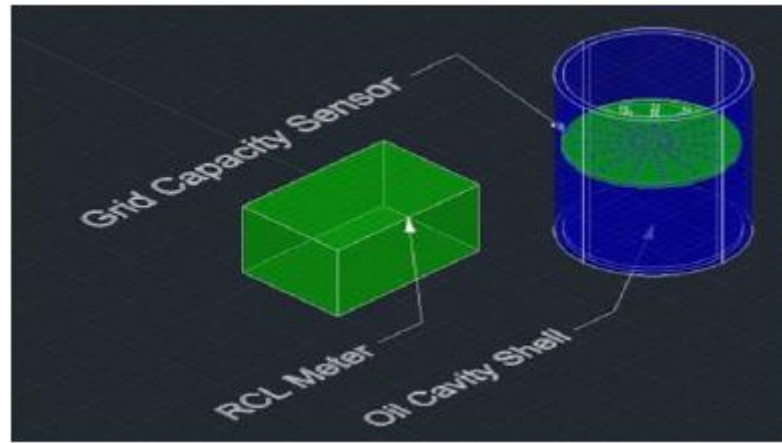

Figure 3.16 – Grid capacitance sensor

In this paper, the programmable automatic RCL meter is used and the capacitance readout from the measuring apparatus is directly related to the input frequency which is explained in the following Equation (3.1).

$$C=0,5\pi fX_C \quad (3.1)$$

where C – is the overall capacitance;

f – is the input frequency;

X_C – is an inductive of components;

Based on preliminary measurements of the dielectric constant of motor oils, it can be concluded that the dielectric constant value varied from 6.5 to 10 pF depending on the input frequency (rate of change of electric current between poles). Turner and Austin (2003) measured the permittivity and magnetic susceptibility and then compared them to the viscosity of the lubricant using an interleaved disk capacitor. The structure of the sensor is shown in figure 3.17 [27].

The authors first measured the capacitance of the air which was around 170 pF. Then, at 19 room temperature, the sensor was dipped into the test oil to measure the capacitance of the oil. The dielectric constant was then calculated as:

$$D=C_{OIL}/C_{AIR} \quad (3.2)$$

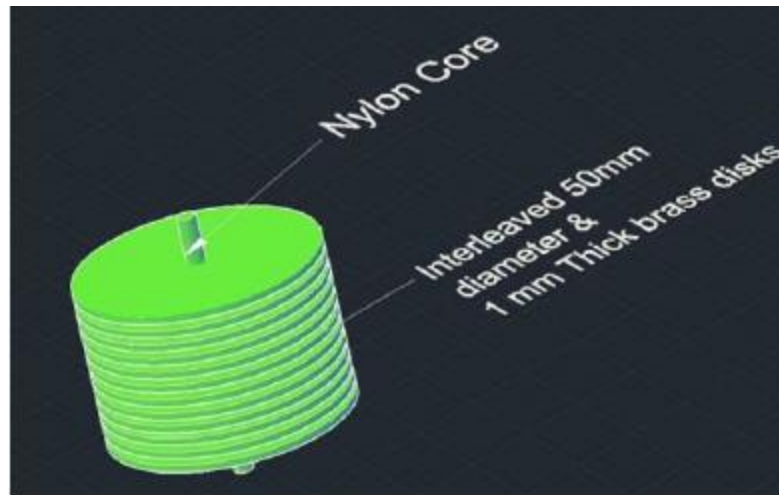

Figure 3.17 – Interleaved-disc capacitor for measurement of dielectric constant

Moreover, Cho and Park designed a wireless sensing system which transmits lubrication oil capacitance information and energy between sensor and reader for automobiles with a capacitive IDT sensor. The sensor is shown in Figure 3.18.

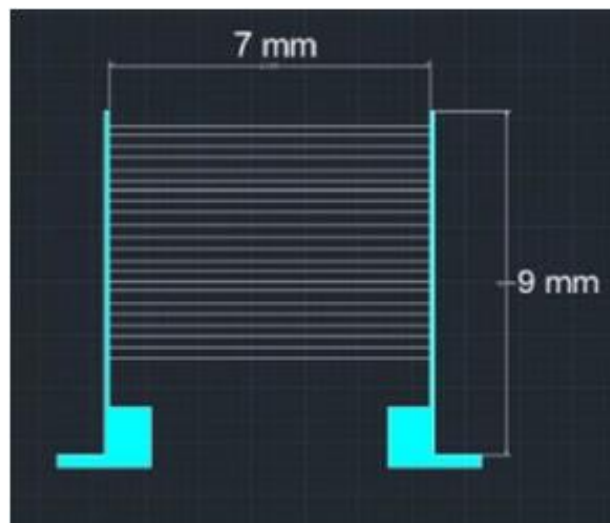

Figure 3.18 – Capacitive IDT sensor

For the relationship between the field strength ϵ applied to the dielectric substance and the polarization P , the polarization is getting bigger when the field strength increase as shown in Equation (3.3):

$$\epsilon_r = 1 + X_e \quad (3.3)$$

And the relationship indicated in equation (3.4) is established between the relative permittivity and electrical susceptibility, which is the degree of polarization caused by an electric field applied to a certain substance. Degraded oil with polar molecules appears to have greater electrical susceptibility than non-degraded motor oil with non-polarization, and it strongly affects metal particles and metal ions, which have increased due to corrosion and abrasion. Accordingly, it can be determined that the more the quality of the engine oil deteriorates, the more the dielectric constant of the engine oil increases. Jakoby and Vellekoop [] combined a dielectric constant (capacitance) sensor with microacoustic viscometers to detect water-in-oil emulsions. The MG (Maxwell-Garnett) rule has been identified as a suitable tool for effect size prediction. The relative dielectric constant of oil, which is 2÷3, is very different from water, where it is 80. The effect of water contamination on the dielectric constant of the mixture can be expressed as:

$$\varepsilon_{r,m}=(1-f)\varepsilon_{r,o}+f\varepsilon_{r,w} \quad (3.4)$$

where $\varepsilon_{r,m}$ – stands for the relative permittivity of the mixture.

Several commercially available sensors developed by Kittiwake Developments Ltd are also capable of online oil quality detection by way of interpreting lubrication oil dielectric property. For example, the Kittiwake on-line oil condition sensor (Fig. 3.19) uses a combination of proven Tan Delta dielectric sensing and smart interpretation algorithms to detect lubrication oil oxidation. As mentioned above, TAN is a commonly used performance parameter to describe lubrication oil oxidation. So, by mean of correlating lubrication oil oxidation and the dielectric property variation, online oil oxidation monitoring is achieved. Also, based on similar dielectric property monitoring theoretical base, the Oil Quality Sensor (Fig.3.20) developed by Tan Delta Systems Ltd is capable of water contamination and oxidation online detection. Moreover, a specialized Moisture Sensor (Fig. 3.21) developed by Kittiwake Developments Ltd is also commercially

available. This sensor uses a combination of proven thin film capacitance sensor and special developed algorithm to perform relative humidity detection.



Figure 3.19 – On-line oil condition sensor (Kittiwake Developments Ltd)



Figure 3.20 – Oil quality sensor (Tan Delta Systems Ltd)



Figure 3.21 – Moisture sensor (Kittiwake Developments Ltd)

Since many previous oil conditions diagnostic techniques focus on monitoring the basic degradation features like oxidation and soot concentration. They are not capable of performing online data acquisition. By means of correlating dielectric constant variation data with basic degradation data acquired from traditional lubrication oil condition monitoring sensors, one can achieve online lubrication oil deterioration detection. The advantages of dielectric constant include: all degradation feature coverage, online health monitoring capability, and low data processing complexity and maintenance cost. The disadvantage is that most of them need special design and fabrication special fabricated lubrication oil electrical conductivity sensor is another direction scientists have been working on. As reported in their paper by Seung-II Moon et al. [], by measuring the electrical conductivity of the oil with a carbon nanotube (CNT) sensor (Figure 3.22), the oxidation rate of the lubricating oil can be monitored. They compared the CNT conductivity data with the TAN of the tested oil, and the results showed that the CNT sensor was effective in reducing oil oxidation deterioration.



Figure 3.22 – CNT oil sensor

Hedges et al. developed Polymeric Bead Matrix (PBM) technology for on-board condition based monitoring of fluid-lubricated aircraft components (Fig.3.23). This technique utilized the electrical properties of an insoluble polymeric bead matrix to measure oil degradation. Charged ion groups were covalently bound to the matrix. By measuring the impact of solvating effect on the electrical characteristic (conductivity and polarity) of the matrix, lubrication oil deterioration monitoring was achieved. This sensing technique can monitor water

and particle contamination along with oxidation. However, the sensor does need to be replaced along with the replacement of the oil.



Figure 3.23 – CNT oil sensor

3.2.6 Magnetic Susceptibility

Monitoring the magnetic properties changes when oil degrades was the earliest developed system for lubrication oil diagnostic. Halderman used a magnetic plug placing in the flow of oil. The plug has to be removed and ferromagnetic fragments were collected. The fragments were then inspected for condition analysis. Ferromagnetic fragments analysis usually calls for complicated micro scopes and is time consuming. Turner and Austin used a magnetic susceptibility balance trying to investigate links between magnetic properties of lubrication oil and its usage, measured by viscosity variation. Figure 3.24 shows a typical commercial magnetic balance.



Figure 3.24 – Commercial magnetic balance (Sherwood Scientific. Ltd)

The result shows that the magnetic characteristics of lubricating oil do change as the oil degrades, but the measurement were poorly correlated with viscosity and do not seem to offer much promise as the basis of an oil monitoring system. Even though magnetic susceptibility balance and magnetic plug provides the simplest solution for oil deterioration sensors, they have poor correlation with viscosity, not sensitive or calls for complicated further data processing. Currently, most magnetic based oil condition monitoring techniques are used for oil bourn metallic particle detection like ferrous particle which is one of the most common results of component wear. Typical systems includes Patrol-DM™ wear debris monitor developed by Poseidon Systems, LLC as shown in Figure 3.25 and On-Line Metallic Wear Debris Sensor along with On-Line Ferrous Wear Debris Sensor developed by Kittiwake Developments Ltd as shown in Figure 3.26 and Figure 3.27 respectively. These systems are sensitive with metallic particle contamination. However, particle contamination is only one of the 3 basic degradation features of the lubricant.



Figure 3.25 – Patrol-DM™ wear debris monitor (Poseidon Systems, LLC)



Figure 3.26 – On-line metallic wear debris sensor (Kittiwake Developments Ltd)



Figure 3.27 – On-line ferrous wear debris sensor (Kittiwake Developments Ltd)

Typical commercially available EIS sensor is SmartMon-Oil™ developed by Poseidon Systems, LLC as shown in Figure 3.28. They developed a technique called “Broadband AC Electrochemical Impedance Spectroscopy”. By means of injecting complex voltage signal into the fluid at one electrode, and received by another electrode, the impedances are measured at different frequencies. The measured impedances are then correlated to the chemical and physical properties of the oils. This EIS sensor is capable of measuring water and soot contamination level as well as general oil quality.



Figure 3.28 – SmartMon-Oil™ (Poseidon Systems, LLC)

3.2.7 Micro Acoustic Viscosity

Viscosity variation beyond or below operating limits is commonly considered that lubrication oil is degrading. Because all the basic oil degradation features can be detected by a viscometer including oxidation, water/particle contamination and fuel dilution. Also, the mileage of an engine or operating duration of a gearbox cannot be considered equal to lubricant deterioration reference (operating

conditions, individual operating habits, ambient condition and fuel quality). Viscosity is usually considered lubricant degradation comparison standard for its independence on various operating conditions. Agoston used a micro acoustic sensor to measure the viscosity electrically for automotive applications. This sensor, whose structure is shown in Figure 3.29, is small and has a long life span and can be deployed in aggressive industrial environments. The indirect data provided by the engine management and its relation to the oil wear will depend on the actual engine platform used whereas the data provided by the sensors are directly linked to the oil condition and are thus platform-independent. The micro acoustic viscometer can measure all the basic oil degradation features online with space efficient design. However, lack of practical tests from industry and problems with oil contain viscosity modifiers may limit its application in the industry.

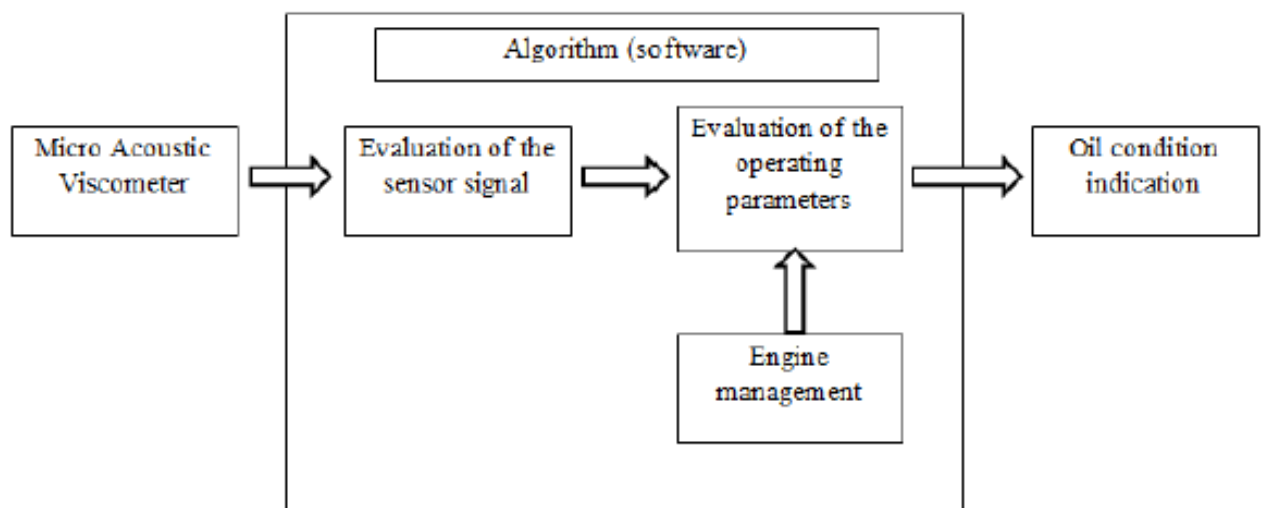

Figure 3.29 – Structure of a sensor assisted algorithm for a lubrication monitoring system

3.2.8 Physical Techniques

Kinematic (Electromagnetic) Viscosity

As it is mentioned in the micro acoustic viscosity sub section, all the basic oil degradation features have influence on the viscosity. Kinematic viscosity can be

acquired by a traditional kinematic viscometer which is also called electromagnetic viscometer as shown in Figure 3.30.

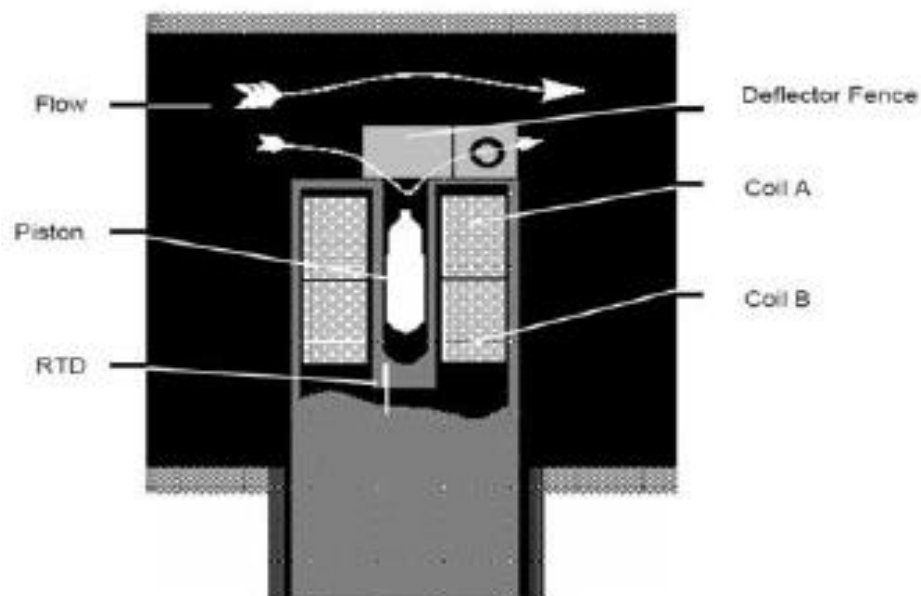

Figure 3.30 – Typical kinematic viscometer structure (Cambridge Viscosity. Ltd)

Ultra Sound

Sound and vibration are used for many health monitoring applications. In the case of oil condition monitoring, early research using ultrasound was published in 1980s . BHRA developed a system with a sensor and receiver. They are placed on opposite sides of an oil flow.

Thermo Conductivity

Another physical approach of lubricant A special designed hot film micro sensor, deterioration detection is thermal conductivity. Kuntner et al. reported that water contamination and degradation processes in mineral oil leads to an increased thermal conductivity, indicating that the potential of thermal conductivity sensors in the field of oil condition monitoring.

Ferrography

As mentioned in the magnetic susceptibility subsection ferromagnetic fragments are collected and send to a laboratory for further ferrography analysis.

Ferrography is a typical traditional oil diagnostic technique for analyzing particles present in lubricants.

3.2.9 Chemical Techniques

pH Measurement

Lubrication oils contain long-chain oxidizable hydrocarbons. In an operating engine, these hydrocarbons are exposed to high temperatures, which make them more vulnerable to be attacked from free radicals.

Thin-film Contaminant Monitor

The lubrication oil performance stay stable if the oil temperature is maintained within the manufacture recommended range. In case it is not operating in the required condition, the oil deterioration starts and it reflects the degradation of lubricating oil. As a general thumb rule, a 10 rise in temperature doubles the oxidation rate and so is formation of oxidation products.

Optical Transparency or Reflectometry

With the goal of achieving online oil deterioration analysis, optical oil condition monitoring techniques was born. This technique usually correlates oil optical transparency or reflection rate with oil general degradation basic features.

IR Absorption

When oil deteriorates, nitrate compound is generated. This compound absorbs infrared (IR) radiation with a wave length of 6.13 μm . This effect was used in a sensor that measured the IR absorption along a fix path length and attempted to correlate the measurement with oil condition.

3.3 Analysis and basics of laser vibrometry

Obtaining advanced scientific and technical reserve to ensure the development of aircraft engines and gas turbine units is impossible without a fine physical experiment, which is aimed at a detailed study of a process or phenomenon, without experimental testing of new theoretical models, where sometimes you need measurements of exotic parameters and extensive measurement capabilities and, finally, without testing new equipment, measurements, accompanied by new types, and higher requirements for the measurement procedure. Increased accuracy requirements, the width of the range, the informativeness of the measurements. It is necessary to add that all these measurements are made, as a rule, in difficult conditions (in high-temperature, high-speed, high-turbulent flows, on rotating details in unsteady conditions) [23].

To a greater extent, these requirements are met by a new class of control and measuring systems based on the use of laser sources of coherent radiation. The laser is a unique radiation source with a good combination of such properties as monochromatic radiation, small angular divergence, coherence and high spectral energy density of the radiation.

Thanks to these properties, the laser was able to provide non-contact and remote measurements, increase the resolution of existing measurement methods, and increase their productivity and accuracy. Methods and tools for laser vibrometry of structures are developing rapidly. The high accuracy of determining physical quantities characterizing various oscillatory processes, combined with high information content and the ability to automate measurements, which allows the use of laser devices for vibration testing as diagnostic tools, opens up new opportunities for transport for the operation of power plants.

Non-contact methods of vibrometry are based on the comparison of controlled parameters with the wavelength of laser radiation. These methods are the most accurate compared to other measurement methods. With the help of laser instruments, it is possible to measure oscillation amplitudes from zero angstroms to several meters in a practically unlimited frequency range.

One of the most important tasks at the present stage is the development of new laser measuring equipment and the introduction of devices that have already proven themselves in various branches of mechanical engineering. The need for laser vibrometers in metrological practice is especially great, since they are exemplary. However, the practical implementation of laser vibrometers faces certain difficulties, which are largely due to the fact that the conscious use of laser measuring instruments requires a combination of a sufficiently high level of knowledge in such diverse fields of science and technology as coherent optics, laser technology, mechanics, and applied mathematics.

Vibration is a periodic oscillation of points on the surface of an object and is characterized by amplitude, frequency, phase and direction of movement. Currently, contact methods are widely used to measure vibration parameters relative to massive objects, which are based on the use of vibration sensors mounted directly on the object. To control small or thin-walled objects, hard-to-reach or objects heated to high temperatures, non-contact, mainly optical methods are used. Any optical method for measuring vibration parameters includes the following operations:

- object lighting;
- transformation of vibration parameters of an object into optical radiation parameters, which is characterized by a change in time according to a given law of amplitude, frequency, phase or polarization of an electromagnetic wave (modulation of light);
- detection of radiation reflected from the object by the corresponding parameter;
- mathematical processing of the detector signal and representation of vibration parameters in specified units.

As the light-sensitive element of the photo-detectors are now widely used so-called photoelectric detectors of optical radiation: photoresistors, photodiodes, photopanoramas and more complex devices, made on their basis (photopotential, matrix of photodiodes). These elements are sensitive only to the intensity of the

radiation, so to extract information placed in the frequency, phase or polarization of the reflected from the object (or passed through it) optical signal, the composition of the photodetectors includes a variety of interferometric or polarization optical discriminators, lenses and aperture [].

The most convenient light sources are lasers, the radiation of which, in addition to the intensity, is also characterized by high coherence and sharp directivity.

For mathematical processing of the photodetector signal, convenient and operational presentation of the results, as a rule, personal computers with the appropriate hardware and software are used.

3.3.1 Methods of laser vibrometry

Of all the sources of radiation of the optical range, laser sources are characterized by the highest degree of coherence and monochromaticity of the radiation they generate.

In addition, lasers have the following positive properties: high stability and reproducibility of the radiation frequency, small angle of divergence, low sensitivity to changes in ambient temperature, which is especially important in metrological studies.

Therefore, in the development of devices designed for precision measurement of motion parameters in mechanical engineering, laser sources are widely used.

Methods for converting vibration parameters into an electric signal can be classified by the method of extracting information about the parameters of motion (photoelectric, interference, doppler) and by the method of receiving information about the parameters of motion (single-frequency, two-frequency, etc.).

Photoelectrical conversion methods are based on the measurement of changes in the intensity of laser radiation, interference – on the use of interference phenomena in the optical range, doppler – on the change in the frequency of laser radiation reflected from the object of vibration control.

In both interference and Doppler methods, the two-beam Michelson interferometer became widespread (Fig. 3.31).

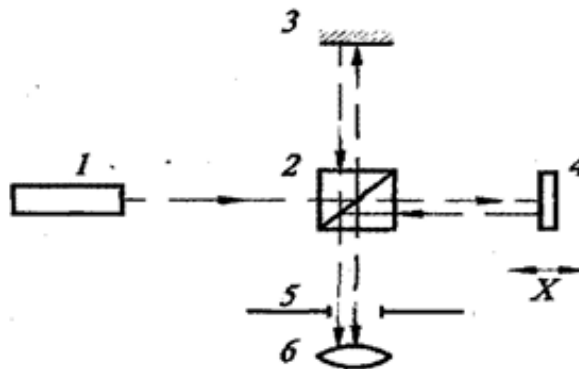

Figure 3.31– Schematic of the Michelson interferometer: 1 – laser; 2 – light dividing cube; 3 – fixed mirror; 4 – movable mirror 5 – eyepiece; 6 – diaphragm

Laser radiation I enters the dividing cube 2 and splits into two parts. The resulting rays are directed to the stationary reflector 3 and the reflector moving together with the measured object 4, respectively.

Thus, it is possible to measure the value of the movement of the mirror 4 by the number of transitions of the illumination change that have passed through the aperture 6. One transition corresponds to half the wavelength of laser radiation.

An interference pattern is observed in eyepiece 5. If the interferometer beam path difference $\delta_0=0; \pm\lambda/2; \pm2\lambda/2$, then the interference field has maximum illumination. With the difference in the course of the rays $\delta_0= \pm\lambda/4; \pm3\lambda/4$, then the rays converge in opposite phase and the interference field has a minimum illumination.

The main methods of laser vibrometry, which received the real embodiment in the devices, are shown in fig. 3.32 [24,25].

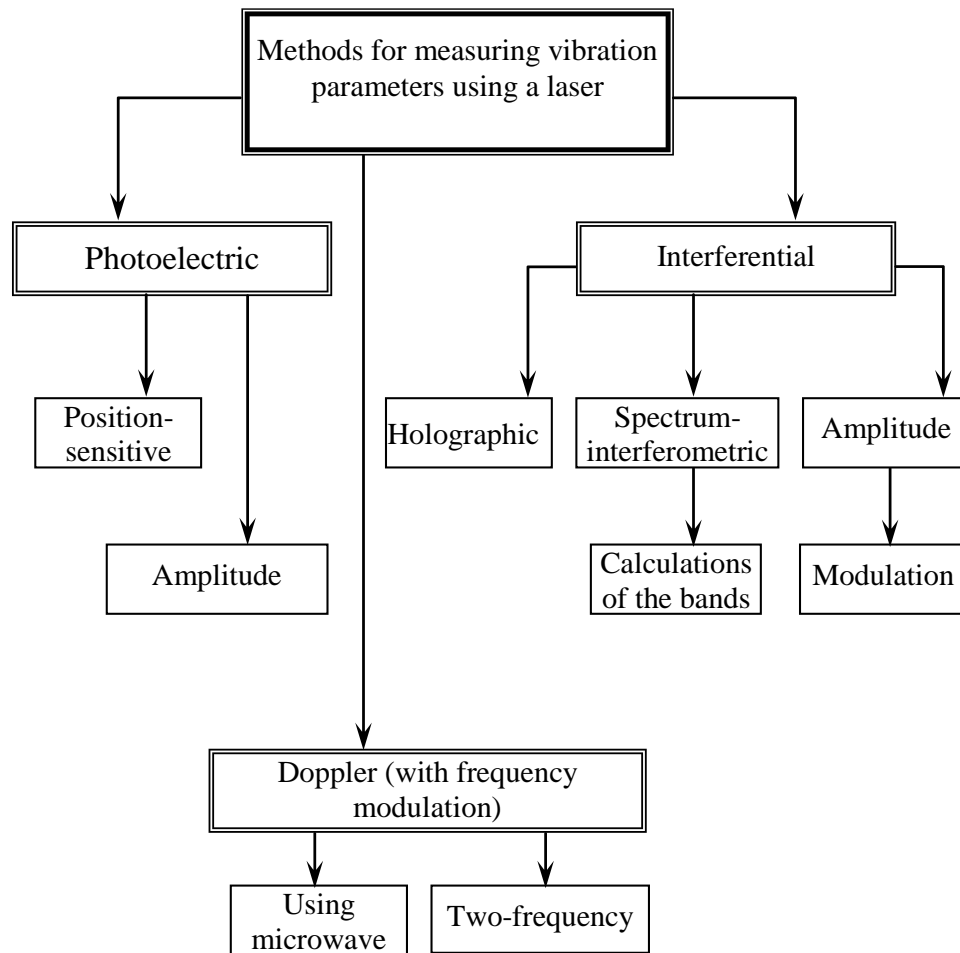

Figure 3.32 – Classification of laser vibrometry methods

Currently, laser vibrometers based on the Doppler effect are developing most rapidly (Fig.3.33÷3.34). They have the following advantages:

- determine the possibility of obtaining a high signal/noise ratio;
- provide frequency and spatial suppression of the external highlighting background without the use of optical filters;
- allow to measure the parameters of mechanical vibrations of complex shape at considerable distances from the object of measurement;
- have high noise immunity;
- allow the analysis of the output signal of the photodetector in the frequency range exceeding the region of low-frequency noise of the photodetector and laser.

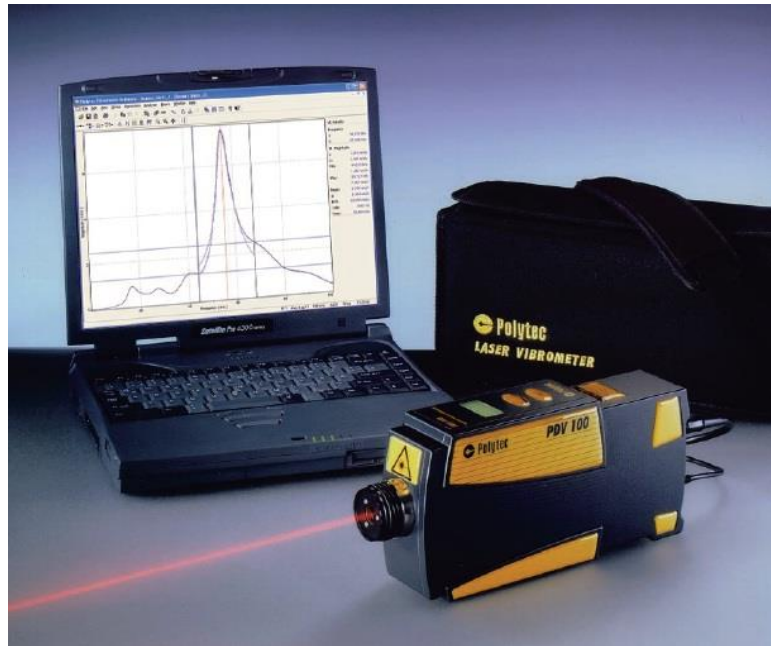

Figure 3.33 – Laser vibrometer of the company «Polytec»

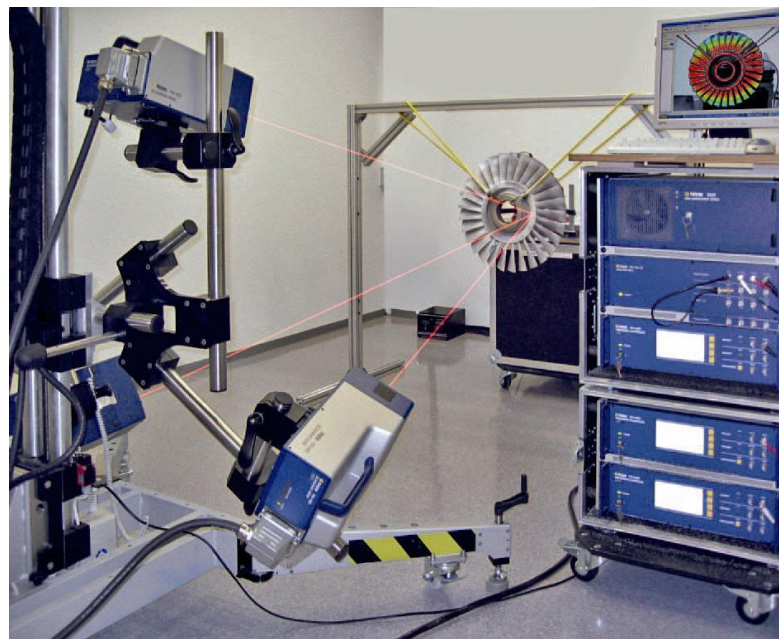

Figure 3.34 – Application of a laser vibrometer

Example of a laser vibrometer

As an example, consider the PSV-400 scanning vibrometer. The scanning vibrometer PSV-400 (Fig.3.35) has modern software and hardware. It includes a compact sensor head with an integrated scanning module, a vibration meter controller and a data acquisition and management system. A powerful software

package manages scanners, data processing and visualization of measurement results (Fig.3.36)..



Figure 3.35 – PSV-400 scanning vibrometer

The vibrometer has simple and intuitive operation, especially when compared to traditional multi-sensor measurement methods, when it takes time to prepare the test object and sensors. To configure the test, you need to define the geometry and scanning points. The vibrometer automatically passes the beam through all points of the scanning grid, measures the response, and confirms the correct measurement by checking the signal-to-noise ratio. When the scan is complete, you need to select the required frequencies and visualize the waveforms in 2D and 3D modes (Fig.3.36) [26].

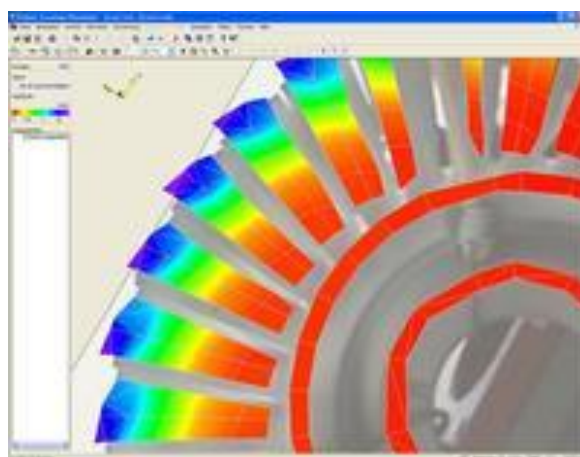

Figure 3.36 – Visualization of the vibrometry process

This is an extremely effective tool in understanding the vibration features of a structure.

An excellent measuring device for collecting three-dimensional vibration data for both simple and complex structures:

- ✓ simultaneous measurement with three sensor heads with high spatial resolution;
- ✓ intuitive-3D animation of measurement results with separation of vector components in and out of the plane is available;
- ✓ interface for data exchange with finite element and modal analysis software

PSV-400-3D is based on the well-known PSV(Polytec scanning Vibrometer) technology. Using three independent touch heads and controllers at each scanning point. Vibration velocity is measured simultaneously in three directions. Three sensors are centrally controlled by software.

A typical measurement involves the following steps:

- Location of sensor heads in front of the research object;
- Setting the global coordinate system;
- Designation of points on the object;
- Setting parameters for analog and digital collection of registered values;
- Start scanning;
- Data analysis and export.

The Polytec three-component vibrometer simultaneously measures all three linear velocity components at the point of oscillation of the structure.

The small measured volume allows non-contact three-dimensional vibration measurements of even small structures.

Real-time analog output of V_x , V_y , and V_z components with vibration frequencies over 250 kHz.

Since the mid-60s of the last century, laser technologies began to become an integral part of scientific and technological processes, gradually finding new areas of application. The Doppler effect, used in laser radiation decoders, was first used to measure the flow rate of liquids, and then its application expanded significantly to measure the vibration of parts and products during their operation and tests in

laboratory conditions on vibration equipment. This is how laser (Doppler) vibrometry was born. The Doppler effect is that light (wave radiation) reflected from a moving object changes its frequency in proportion to the speed of the object. Given that a laser beam is monochromatic radiation (at one specific wavelength or at several specific wavelengths), we can very accurately measure the Doppler shift of its frequency when reflected from an oscillating object, and thereby very accurately measure the speed of such an object. Moreover, the Doppler shift almost linearly depends on the speed of the illuminated (irradiated) object.

Of particular interest is the measurement of the Doppler shift in vibrometry, which allows you to measure at any visible point without adding a mass (inertial) load, because the accelerometer sensor glued to the product adds mass and changes the vibration characteristics of the object. In addition, it is not always and not everywhere possible to install an accelerometer, especially on hot or light products, not to mention the distortion of data due to the initial viscosity of the adhesive layer or the need to drill the object to install the pin. Therefore, laser vibrometry differs from the traditional one in its huge measurement ranges, high accuracy and reliability. Another advantage of laser vibrometry is related to the ease of measuring in many points of the object due to the redirection (expansion) of the laser beam. Therefore, the scanning laser vibrometer allows you to build a non-contact method of a complete vibrogram of the product under real load during operation or in the laboratory to identify weak points or resonant places in the structure in order to improve the vibration and acoustic characteristics of the tested product.

Leaders in these two directions (laser vibrometry and multi-axial load vibrostands) can be considered the German company OptoMET and the Japanese Shinken. The Japanese company was founded in January 1975 and since then has been engaged in multi-axis energy-saving equipment for electrodynamic vibration testing, and a patent for a multi-axis shaker was obtained as early as 1988. Germany's OptoMET from Darmstadt is more focused on laser vibrometry and

digital signal processing applications by using UltraDSP digital signal processing in one device together with high-sensitivity analog measurement. The OptoMET company was one of the first to release SWIR (Short Wavelength Infrared) laser vibrometers.

OptoMET laser vibrometers provide stable measurement on dark/rough surfaces in the frequency range up to 24 MHz and more, measure the vibration velocity of objects up to 50 m/s, acceleration up to 78 Mg and vibration displacement up to ± 2.5 m. This laser Doppler vibrometer has distances measurement (setting distance) from 0 mm to more than 300 m. In the measuring head, a laser is used for measurements (Fig.3.37).



Figure 3.37 – OptoMET laser vibrometer

Focusing in automatic, remote (PC control) and manual modes. Outputs: analog BNC and digital Ethernet. The Optomet FIBER vibrometer is equipped with OptoGUI software for data collection, analysis and remote control.

The software allows you to perform Fast Fourier Transform (FFT) calculations directly during the measurement process. Data are displayed in the frequency domain (spectrum) and the SFP line (up to 8 million). Automatic identification of signal peaks in the frequency range is carried out. It is possible to set the limits of the FFT with certain time ranges of data. A signal trigger is implemented to trigger a velocity, displacement, or acceleration signal measurement.

As a scanning laser vibrometer, we can recommend the Optomet Scan series, which allows you to automatically test the entire product in one session, without contact and without the vibrometer itself affecting the product.

Scanning vibrometry allows you to easily calculate local resonance and the nature of vibrations of all structural elements of the product. Scanning angle -50×40 degrees with a resolution of <0.0020 . The density of scanning points is up to 512×512 . Captures an image with a CCD camera and displays the vibration field in real time.

Vibration is measured by three parameters: vibration acceleration, vibration speed and vibration displacement.

Vibration acceleration

Vibration acceleration characterizes the condition of the internal parts of the equipment that cause vibrations. For example, it is possible to draw conclusions about the condition of the turbine rotor or bearings based on vibration acceleration. Vibration acceleration is measured in mm/sec^2 .

Vibration speed

Vibration speed is the speed of movement of the control point along the axis of measurement. This parameter is used to judge the effect of vibration on the supports of the equipment. Vibration speed is measured in mm/sec .

Vibration displacement

Vibration displacement determines the limits of control point elimination due to vibration. Measured in micrometers or millimeters, it shows the distance between the peaks of the control point elimination.

The indicators of vibration acceleration, vibration speed and vibration displacement obtained with the help of a vibrometer or vibration analyzer are compared with the table values. According to the deviation of indicators from the norm, the specialist determines the condition of the equipment.

Measurements are made in three directions: transverse, axial and vertical. Exceeding the vibration norm in the transverse direction indicates an imbalance of

the equipment. Exceeding the norm in the axial direction indicates misalignment of the equipment. Increased vertical vibration indicates failure of the supports or foundation.

Modern digital vibrometers can measure vibration acceleration and vibration displacement.

Vibrometers are equipped with piezoelectric sensors that are attached to the equipment during measurement. To measure vibration, the specialist selects the mode of vibration speed, vibration acceleration or vibration displacement, turns on the device and saves the received data in memory or writes a measurement log.

Vibrometers also support high-frequency vibration measurement mode. It allows drawing conclusions about the condition of the equipment's bearings.

Modern vibrometers, in addition to measuring vibration, determine additional parameters. For example, Fluke 805 measures the temperature of bearings (Fig.3.38).

What is a vibration analyzer?

A vibroanalyzer is a more complex measuring device compared to a vibrometer. The analyzer performs all the functions of a vibrometer, i.e. it measures vibration velocity, vibration displacement and vibration acceleration.

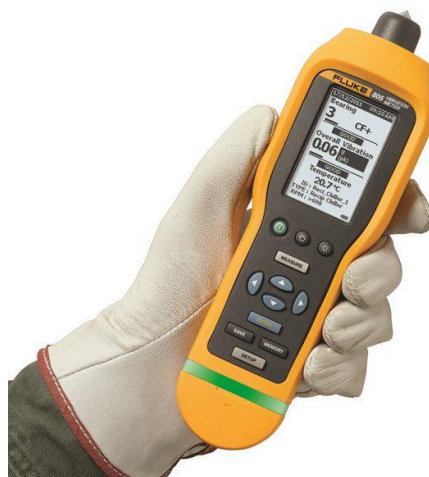

Figure 3.38 – Fluke 805 vibrometer

Unlike a vibrometer, a vibroanalyzer allows you to monitor vibration in dynamics. The device displays or saves graphs of vibration changes on the screen.

That is, with the help of a vibrometer you can measure the vibration at a specific moment in time, and with the help of the analyzer you can evaluate the change in this parameter.

Vibroanalyzers are single-, double- and multi-channel. The more channels, the more complex the device performs measurements.

Single-channel vibration analyzers are usually used for equipment diagnostics and balancing. This is the cheapest type of analyzer.

The two-channel analyzer is a universal solution for specialists who repair equipment and are engaged in commissioning work.

Multi-channel vibration analyzers are used in laboratories and design bureaus. These are complex and expensive instruments that equipment developers and scientists need.

Such devices measure several vibration signals simultaneously. This is very useful for diagnosing complex defects. Multi-channel analyzers have several sensors, which are followed by several wires. Therefore, they are not as convenient as single-channel ones. You won't be able to work with them with one hand. And the price immediately increases a lot.

But multi-channel devices have a larger screen, more options for signal processing.

Multi-channel devices can be assembled in one case or on the basis of a portable computer (separate sensor connection unit and separate laptop computer).

Multi-channel devices have a separate channel for connecting a phase marker. This allows for on-site balancing and measurement of signals tied to the rotation phase of the unit.

Such devices have many other measurement modes, but they are used only in very difficult cases. For example, the Acceleration-Overrun mode allows you to trace the change in vibration during acceleration and stopping of the unit. A graph of the dependence of the amplitude and phase of vibration on the rotation frequency is built, which allows determining the resonant frequencies of the unit.

Vibration values measured over a period of time (for example, after one month) make it possible to forecast the development of vibration and plan the timing of subsequent repairs. This gives a significant saving of money compared to planned repairs.

The ONIX portable vibroanalyzer allows you to monitor the current state of units, to perform in-depth diagnostics and balancing in your bearings in an automated mode, as well as to determine your own frequencies of structures (Fig. 3.39). ONIX can be used both as a vibration analyzer and as a data collector in the collector mode (route operation).



Figure 3.39 – ONIX vibration analyzer

The Onix vibration meter implements the maximum set of measurements for one-channel and two-channel analysis, as well as a number of research functions that allow you to significantly increase the informativeness and reliability of diagnostics. The use of universal measuring inputs provides the possibility of connecting vibration sensors of various types, which significantly expands the capabilities of the device.

Maximum functionality

In addition to the standard types of measurements (general level, amplitude/phase, spectrum, spectrum of the envelope, temporal signal, etc.), the ONIX vibroanalyzer implements a number of special research functions aimed at increasing the reliability of diagnostics, such as the measurement of a temporal

signal dump (up to several hours), cepstral analysis, as well as a new method of evaluating non-stationary processes - wavelet analysis, which is gaining more and more popularity among diagnosticians and researchers.

Due to the possibility of synchronous measurements of various vibration parameters at the same time on two channels, extremely informative types of measurements such as orbits and mutual spectra were implemented in the vibroanalyzer, as well as an algorithm for calculating the mutual phase was developed, which allows detecting a number of defects of the rotary equipment without using a tachometric sensor.

The practically unlimited amount of memory of the device made it possible to create new types of measurements, research functions and even diagnostic methods at the development stage, which can be used by specialists during in-depth diagnostics of the equipment both during measurements and during subsequent analysis.

Modular construction principle

A large amount of memory does not impose any restrictions on the permissible maximum size of the embedded software. Therefore, as the platform develops, the ONIX vibration analyzer can be supplemented with new functions, software modules and diagnostic methods.

Purpose of the Atlant-32 analyzer

The Atlant-32 multi-channel synchronous 32-channel recorder-analyzer of vibration signals is a modern device designed to solve the most difficult tasks in vibration diagnostics of the state of the equipment (Fig.3.40). With the help of the Atlant-32 vibration analyzer, you can hang sensors on the entire turbogenerator. The basis of the Atlant vibroanalyzer is a portable computer of the "laptop" type, which combines the functions of signal registration, processing, and storage. The functions of primary processing of vibration signals, filtering and synchronous digital conversion are implemented in the external unit. Vibration sensors and a phase marker used in balancing are connected to this unit. The use of a signal

processing computer removes almost all the limitations inherent in conventional portable vibration monitoring devices. This is a small number of input channels, low speed, limited memory. The possibility of continuous recording of signals for tens of seconds or minutes allows such devices to be used for recording transient processes in equipment, control of vibration processes in slow-moving mechanisms, etc.



Figure 3.40 – Vibroanalyzer Atlant-32

The technical parameters of the Atlant-32 vibroanalyzer are given in the table.3.2.

Table 3.2 – Technical characteristics of the Atlant-32 analyzer

Parameter	Value
The number of analog signal registration channels	32
Channel survey frequency during signal registration, Hz	5÷20000
The frequency range of the supplied vibration sensors, Hz	5÷5000
The duration of temporary signal samples	0,01сек÷30 хв.
Frequency resolution of received spectra, lines	100÷3200
Operating time from internal power sources, h.	2,5÷4,0
Weight of the device in packaging without sensors, kg.	10

The Atlant device includes a set of vibration diagnostics programs. With the help of the Atlant software, you can analyze the temporal forms and spectra of vibration signals, wavelet – signal transformation. Software tools for spatial visualization of multidimensional oscillations can be of great benefit in diagnosis.

For ease of use, the software includes ready-made vibrodiagnostic systems:

- Automated system for diagnostics of the technical condition and search for defects of rotating equipment based on the spectra of vibration signals;
- Language for writing diagnostic rules, with the help of which the user can use all his diagnostic work;
- A system for early diagnosis of defects in the state and installation of rolling bearings based on the spectra of the vibration vibration signal;

Carrying out balancing and stabilization of rotors in their own bearings - up to 14 correction planes and 42 control points.

If you need to measure vibration to determine the health of the equipment, then inexpensive vibrometers are in demand. If, in addition to equipment diagnostics, repair and adjustment is required, then a vibration analyzer is suitable. A single-channel analyzer is sufficient for equipment balancing, and multi-channel vibration analyzers are required for accurate diagnosis and repair.

Conclusions to part 3

Oil analysis is an important tool in any maintenance program, providing valuable information about the condition of the oil and, as a result, about the condition of the engine. To be the most effective, oil analysis should be used in the maintenance of the engine to take immediate effects in case of deviations. The oil analysis program reduces the risk of unexpected breakdowns and eliminates the costs associated with the downtime of the equipment.

The above oil analyzers (oil spectrometers) are a useful diagnostic tool that provide information in the shortest time. Fully automated measurements, diagnostic and cleaning systems allow any company to implement its own diagnostic program. This does not require special qualifications of personnel and special means of his work. Its main advantages are quick results for immediate decision -making and automation. Anyone can manage this tool. The analyzers have proven their ability to provide reliable data, which allowed the operators to make faster decisions with the results obtained in less than 15 minutes.

This work describes a study of online monitoring of the state of lubricating oil and prediction of residual life using the particle filtering method and commercially available online sensors from various existing global manufacturers. The monitoring of the state of lubricating oil and the detection of degradation of gas turbine engines are given. Viscosity and dielectric constant are chosen as operating parameters for simulating the degradation of lubricants. In particular, the evaluation of lubricant performance and the prediction of the remaining life of a degraded lubricating oil are represented by viscosity and dielectric constant data using particle filtration. A simulation study based on models validated in the laboratory is intended to demonstrate the effectiveness of the developed method.

An analysis of the basics and methods of laser vibrometry, as well as types of existing vibrations and vibration analyzers, was carried out. As a result, we can say that laser vibrometry differs from the traditional possibility of large measurements, high accuracy and reliability. A special advantage of laser vibrometry is associated with ease of measurement at many points of the object

from the reduction (expansion) of the laser beam. Therefore, the scanning laser vibrometer allows you to create using the method of non -contact, the full vibration control of the object during real load during operation or in laboratory conditions to determine weak points or resonant points in the structure.

Non -contact methods of vibrometry are based on a comparison of controlled parameters with a wavelength of laser radiation. These methods are the most accurate compared to other measurement methods.

PART 4

ENVIRONMENTAL PROTECTION

4.1 Air pollution by aircraft

Aircraft emit harmful substances together with the exhaust gases of aircraft engines in the airport area, as well as on air routes during the flight. Therefore, air pollution by aircraft occurs on a global scale.

With 300 flights and landings transcontinental liners per day emit into the air about 3,7 tons of carbon monoxide, 2 tons of hydrocarbon compounds (unburnt fuel) and 1,7 tons of nitrogen oxides. Studies conducted at some airports around the world have shown that air pollution exceeded the permissible level. For example, in the Los Angeles airport area, it was recorded that 45% of the time per year, the carbon monoxide content exceeded the maximum tolerances of the norm by 11,5 mg/m³, one day per month could reach 25 mg/m³, and one day per year-by 37,5 mg/m³.

The exhaust gases of gas turbine engines include the following main components that pollute the atmosphere: carbon monoxide, hydrocarbons (methane CH₄, acetylene C₂H₂, ethane C₂H₆, ethylene C₂H₄, propane C₃H₈, benzol C₆H₆, toluene C₆H₅CH₃ and other), nitrogen oxide, aldehydes, sulfur oxide, soot (visible smoke plume behind engine nozzle), benzopyrene. During the operation of turboprop and turbojet engines for one minute in the atmospheric air is emitted 2...4 mg. of carcinogenic substances, mainly of benzopyrene.

The emission of drained fuel into the atmosphere by aircraft engines according to the ICAO standards is not allowed and should be excluded in the process of designing new aircraft engines.

Currently, the fact of the negative impact of polluted air on human health is no longer in doubt. Polluting harmful substances not only "directly" affect human health, they also affect "indirectly", changing the structure, composition and even the composition of the atmosphere, which in a new capacity has a negative impact globally on human life, as well as on the flora and fauna of the Earth.

Sulphur dioxide (SO_2) irritates the respiratory tract, including bronchial spasm. The General effect is to disrupt carbon and protein metabolism, slowing oxidative processes in the brain, liver, joints.

Hydrocarbons have a pronounced toxic effect.

Carcinogenic substances are chemical compounds that can, when exposed to the body, cause cancer and other malignant tumors, as well as benign tumors.

In 1981, the Committee on aircraft engine emissions (ICAO) developed and adopted draft emission standards and consolidated them into Addition 16 «Environmental Protection».

Emission standards set limits on gas emissions of carbon monoxide (CO), hydrocarbons (CH) and nitrogen oxides (NO_x), as well as aircraft engine smoke and exclusion of atmospheric emissions.

To reduce the emission of incomplete combustion products (CH and CO) in the design it is necessary to increase the coefficient of completeness of fuel combustion, on which the emission index depends EI_{CO} i EI_{CH} . This can be achieved by the use of preliminary evaporation of the fuel, enrichment of the fuel-air mixture in the combustion zone and an increase in the number of combustion zones in the combustion chamber, which allows to regulate the operation of the engines by including or excluding part of the injectors. It is easy to see that these design methods lead to a decrease in specific fuel consumption, i.e. to an improvement in the efficiency of aircraft engines, and thus to a decrease in CO and CH emission indices.

To reduce the emission of nitrogen oxides NO_x from aircraft engines may include the following design solutions: water injection into the combustion zone, the use of two – and multi-zone combustion chambers, applications in the combustion chamber of a catalytic combustion when the temperature of the gases in the combustion zone is reduced, depletion of the combustible fuel-air mixture.

Operational methods for reducing emissions of harmful substances from aircraft engines are based on reducing the duration and changing the modes of

operation of engines in the airport area at the stage of «start-taxiing-takeoff and taxiing after landing».

Reduction of emissions of harmful substances from aircraft engines in the airport area can be achieved by: towing aircraft from the Parking lot to the runway; taxiing aircraft in terms of working engines; the most favorable distribution of aircraft on the runways (with more than one runway) during their takeoff and landing. The use of aircraft towing can reduce the emission of incomplete combustion products in the "start-taxiing" stage before takeoff by 50%, nitrogen oxide-by 5%, and fuel economy-by 25%. The use of this method is justified if the emissions of the towing vehicle are insignificant or if it works, for example, on electric traction.

The content of CO and C_xH_y ingredients in the exhaust gases of aircraft engines is caused by incomplete combustion of fuel in the engine, depending on the characteristics of its combustion chamber (the value of the combustion completeness coefficient η) and the engine operation mode.

The maximum completeness of fuel combustion in the engine takes place in the design mode-take-off (maximum engine power mode). In this mode, modern engines have $\eta = 0,97 \dots 0,99$ ($\eta = 1,0$ with absolutely complete combustion, which is actually impossible to achieve). On all other modes of operation, the value of the η is lower, that is, the completeness of combustion is less ($\eta = 0,75 \dots 0,85$), from the engine into the atmosphere more products of incomplete combustion (CO and C_xH_y , etc.), and the intensity of air pollution increases.

The content of the ingredient NO_x in the exhaust gases of an aircraft engine depends on the temperature of the mixture in the combustion chamber (the higher it is, the more NO_x formation), and it reaches maximum values ($2500^{\circ}C$) at takeoff, and the residence time of the mixture in the combustion chamber (the longer the residence time, the more NO_x formation), and this takes place at low flight speeds of the aircraft. That is, the maximum NO_x emission takes place at the take-off mode of the engine and the modes close to it, when the aircraft takes off and when it sets the altitude.

It is obvious that in the airport area, the emission of an aircraft engine depends on the mode of its operation and the duration of operation in this mode.

Under the area of the airport we will mean the space limited by the height of 1000 m. and the size of the airfield.

Engines of modern airliners operate in the airport area at such modes and such duration of operation (tab. 4.1).

Table 4.1 – Modes and duration of engine operation in the airport area

№ mode	Name of engine operation mode	Relative power, P_e	Duration of the regime, t , min.
1	"Low gas" mode during taxiing before takeoff	0,07	15
2	Takeoff mode	1	0,7
3	Climb mode (1000 m.)	0,85 (або 0,9 nominal)	2,2
4	Approach mode	0,3 (або 0,42 nominal)	4
5	"Low gas" mode during taxiing after landing	0,07	7

де $P_e = P/P_t$, P – the thrust of the engine at a predetermined mode; P_t – engine thrust at take-off (maximum thrust).

The table shows the average values of the parameters (P_e and t) for large airfields in the world.

As can be seen from the table, the most long-term and environmentally dangerous is the regime of low gas. The value of the thrust (power) in this mode for modern aircraft engines is 3%...9% of its maximum value P_0 (N_0). This mode is used during the taxiing of the aircraft before takeoff and after landing, as well as during the warm-up of the engine after launch. The duration of the taxiing mode depends on the size of the airport, the time of day of departure and arrival, the intensity of flights and meteorological conditions.

For a typical modern engine the dependence of emissions of harmful substances on the mode of its operation is as follows (fig. 4.1):

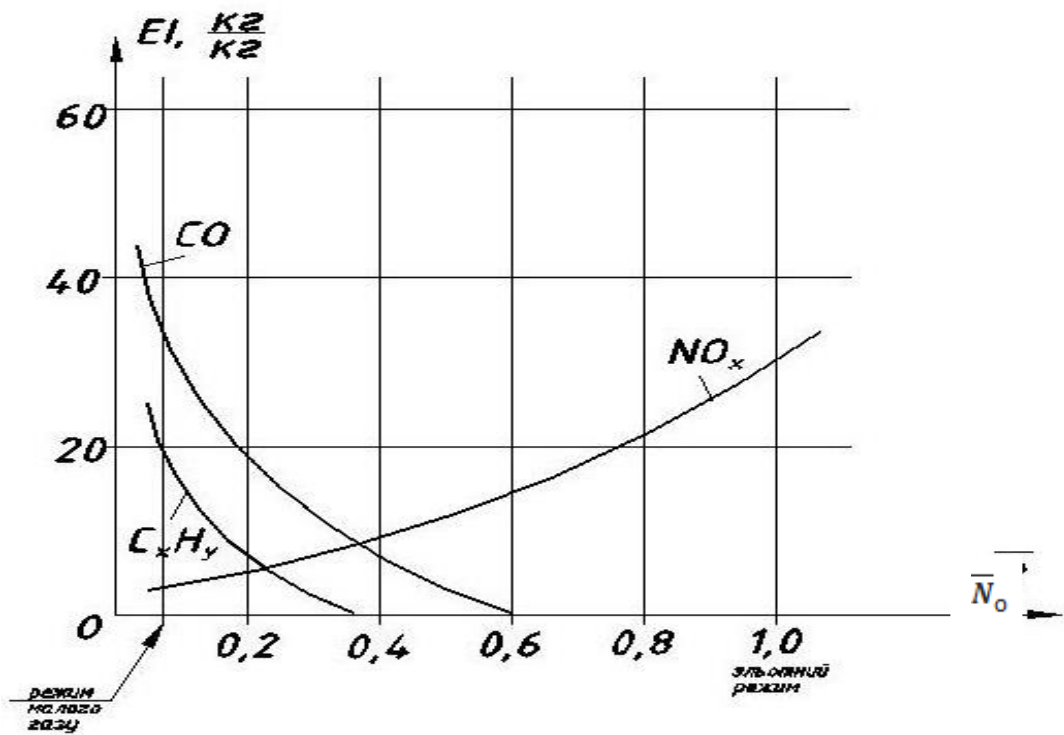

Figure 4.1– Dependence of emissions of harmful substances on the regime engine operation

Determining during certification tests emission indices of harmful substances in the respective modes of operation of the engine, determine the control parameter of emission M_i/P_t of the tested engine, which established the ICAO standards.

This parameter characterizes the «degree of harm» of the engine. In it: M_i - mass in grams of the thrown out i-th harmful substance (ingredient) for any certain time of operation of the engine, $P_t (N_e)$ – takeoff thrust (power) of the engine.

ICAO emission control standards for aircraft engines are currently as follows:

$$\frac{M_{CO}}{P_e} = 118 \frac{g}{kN} ; \frac{M_{C_xH_y}}{P_e} = 19,6 \frac{g}{kN} ; \frac{M_{NO_x}}{P_e} = 40 + 2\pi_t \frac{g}{kN} .$$

4.2 Calculation of aircraft engine emissions

The emission of aircraft engines will be different in the airport area and during the flight along the route, since the engines in these cases operate at fundamentally different modes. In this regard, as can be seen from the above graph (Fig. 4.1), pollution in the airport area is "more harmful" (on the route

$P_e = 0.6...0.8$). In addition, the maximum surface air pollution in the airport area, where many people work, is more concentrated and more stable than the total pollution of the upper troposphere on the flight route, which quickly dissipates. Given these circumstances, pollution in the airport area is "more harmful". Therefore, the calculation of aircraft engine emissions in the airport area is more important, and more attention is paid to it than the calculation during the flight along the route.

The "degree of harmfulness" of each aircraft engine is characterized, as mentioned above, by its emission control parameters from various ingredients. That is, the task of calculating engine emissions is to determine the mass of each ingredient emitted from the engine for a certain time it works, M_i (since P_e – engine thrust at takeoff – the largest known from the documentation, such as form engine).

We will calculate the values of M_i for the airport zone (from the above considerations), that is, $M_i = M_{iap}$, in those modes and for the period of time of its operation, while the aircraft is in this zone with the engines running.

And the aircraft in the airport area at least carries out a take-off and landing flight cycle, which consists of such stages:

- starting and warming up the engine;
- taxiing to executive start;
- takeoff;
- a climb of 1000 m.;
- descent from a height of 1000 m.;
- run;
- taxiing to engine stop.

Aircraft engines at these stages operate in different modes. Therefore, for the convenience of calculation, we divide the takeoff and landing cycle of the aircraft into two types of operations: ground operations and takeoff and landing operations, that is

$$M_{iap} = M_{ig} + M_{it-l}$$

Ground operations are starting the engines, warming them up, taxiing the aircraft before takeoff and after landing.

The main characteristic of these operations (from the point of view of engine emission calculation) are those that the aircraft engines operate on one mode – low gas mode (idle) – and in time – these are the longest operations in the airport zone. This fact simplifies the calculation.

The definition of M_{ig} is conducted by the formula:

$$M_{ig} = K_{ig} \cdot G_{Fg} ,$$

where K_{ig} – emission factor of the i -th ingredient during ground operations (kg. ingr. / kg of fuel).

Obviously (by definition), that is, it is the same emission index, if and E_i , K_i are defined during certification tests of engines (tabl. 4.2).

G_{Fg} – the mass of fuel (kg.) consumed by the aircraft engine during ground operations of the takeoff and landing cycle.

$$G_{Fg} = C_{sp} \cdot P_{lg} \cdot t_{lg} ,$$

where C_{sp} (kg/kN·hour.) – specific fuel consumption during engine operation at low gas (given in the engine form, as one of its most important characteristics); P_{lg} – engine thrust at low gas (given in the engine form, as its technical characteristics); t_{lg} (hour) – operating time of the engine at low gas for the takeoff and landing cycle.

Table 4.2 – Emission characteristics of the engine

Parameter	Unit	CO	C _x H _y	NO _x
K_{ig}	$\frac{\text{kg. ingredient}}{\text{kg. fuel}}$	0,035	0,008	0,005
W_{i1}	$\frac{\text{kg.}}{\text{hour.}}$	2,65	2,4	3,5
W_{i2}		0,5	0,5	1,5
W_{i3}		3,5	2,5	0,5

Takeoff – landing operations are takeoff, climb 1000 m., descent from a height of 1000 m. and landing.

In this case, to calculate the emission of aircraft engines, which is in the air, the emission characteristic is the mass harmfulness of the emission of W_i

(kg. ingr./hour.), which shows how much of this harmful substance is released in this mode of operation of the engine per unit time.

W_i is also determined during engine certification tests.

Then the definition is carried out by the formula:

$$M_{it-l} = W_{i1} \cdot T_{1t-l} + W_{i2} \cdot T_{2t-l} + W_{i3} \cdot T_{3t-l},$$

where $W_{i(1,2,3)}$ (kg./hour) – mass emission rate of the i -th ingredient at the appropriate engine operating modes on takeoff, during the climb of 1000 m. and during the descent from a height of 1000 m.;

$T_{1,2,3}$ (hour) – operating time of the engine on takeoff, during the climb of 1000 m. and during the descent from a height of 1000 m.

The values t_{lg} , $T_{1,2,3}$ are taken from the table 4.1. engine operation modes in the airport area.

Having calculated in this way, we determine the control parameter of the engine emission (where P_0 is the takeoff thrust of the engine) and compare it with ICAO standards, concluding about the compliance of this engine with modern emission requirements for this ingredient.

So, we calculate the emission parameters of the engine and its modifications by ingredients CO, C_xH_y i NO_x.

Source data:

$$P_e = 12000 \text{ кг.}; C_{yd} = 0,49 \text{ кг/кг·ГОД};$$

$$P_{MГ} = 700 \text{ кг.}; C_{yd} = 0,7 \text{ кг/кг·ГОД}.$$

We use the data of table 4.2, then we have:

$$K_{COH} = 0,035 \text{ kg. ingred./ kg. fuel}; \quad W_{CO1} = 2,65 \text{ kg. ingred./ kg. fuel};$$

$$W_{CO2} = 0,7 \text{ kg. ingred./kg. fuel}; \quad W_{CO3} = 3,5 \text{ kg. ingred./ kg. fuel};$$

$$K_{C_xH_y} = 0,017 \text{ kg. ingred./ kg. fuel}; \quad W_{C_xH_y1} = 2,5 \text{ kg. ingred./ kg. fuel};$$

$$W_{C_xH_y2} = 0,5 \text{ kg. ingred./ kg. fuel}; \quad W_{C_xH_y3} = 2,5 \text{ kg. ingred./ kg. fuel};$$

$$K_{NO_x} = 0,005 \text{ kg. ingred./ kg. fuel}; \quad W_{NO_x1} = 3,5 \text{ kg. ingred./ kg. fuel};$$

$$W_{NO_x2} = 1,5 \text{ kg. ingred./ kg. fuel}; \quad W_{NO_x3} = 0,7 \text{ kg. ingred./ kg. fuel}.$$

From the table of operating modes of the engine in the airport area should:

$$t_{lg}=15+7=22 \text{ min.}=0,367 \text{ hour}; \quad t_{23-II}=2,2 \text{ min.}=0,0367 \text{ hour};$$

$$t_{1-t}=0,7 \text{ min.}=0,0117 \text{ hour.}; t_{3-t}=4 \text{ min.}=0,067 \text{ hour}$$

Then:

$$G_{\Pi H} = 0,7 \cdot 650 \cdot 0,367 = 145 \text{ kg};$$

$$M_{\text{CO}_H} = 0,035 \cdot 145 = 5,08 \text{ kg};$$

$$M_{\text{CH}_H} = 0,008 \cdot 145 = 1,15 \text{ kg};$$

$$M(\text{NO})_H = 0,005 \cdot 145 = 0,725 \text{ kg.}$$

$$M_{\text{CO}_{3-\Pi}} = 2,65 \cdot 0,0117 + 0,5 \cdot 0,0367 + 3,5 \cdot 0,067 = 0,284 \text{ кг};$$

$$M_{\text{C}_x\text{H}_y\text{-}\Pi} = 2,4 \cdot 0,0117 + 0,5 \cdot 0,0367 + 2,5 \cdot 0,067 = 0,214 \text{ кг};$$

$$M_{\text{NO}_x\text{-}\Pi} = 3,5 \cdot 0,0117 + 1,5 \cdot 0,0367 + 0,5 \cdot 0,067 = 0,130 \text{ кг.}$$

$$M_{\text{CO}} = 5,08 + 0,28 = 5,36 \text{ kg};$$

$$M_{\text{C}_x\text{H}_y} = 1,15 + 0,214 = 1,35 \text{ kg};$$

$$M_{\text{NO}_x} = 0,725 + 0,130 = 0,86 \text{ kg.}$$

$$\frac{M_{\text{CO}}}{P_e} = \frac{5360}{120} = 44,7 \text{ g/kN} \leq 118 \text{ g/kN};$$

$$\frac{M_{\text{C}_x\text{H}_y}}{P_e} = \frac{1135}{120} = 9,8 \text{ g/kN} \leq 19,6 \text{ g/kN};$$

$$\frac{M_{\text{NO}_x}}{P_e} = \frac{870}{120} = 7,25 \text{ g/kN} \leq 40 + 29 \text{ g/kN.}$$

The terms of the ICAO standards for categories of harmful emissions are met.

A similar method is easy to calculate the degree of pollution of areas of the airport all aircraft, say a year (that is, to determine the mass of harmful substances, throw away the engines of all aircraft in the airport for the year) or how many harmful substances emits an aircraft during a flight on a given route.

Conclusions to part 4

The influence of aircraft on environmental pollution and human health is analyzed. The listed composition of harmful substances emitted into the atmosphere by aircraft engines, and their analysis. Both constructive measures and organizational measures to reduce harmful emissions have been worked out. The engine of the aircraft according to its emission characteristics meets the standards of the ICAO.

PART 5

LABOR PROTECTION

5.1 Hazardous and harmful production factors during operation or repair of the power plant

The main dangerous and harmful factors in the maintenance of the power plant is:

- increased noise levels in the work area (more 80–90 dBA), vibration during engine start-up and testing and ultrasonic inspection of engine parts;
- unprotected movable elements of the aircraft and power plant (PP) (fans, rotating rotors of the engine and units, hood flaps), lifting mechanisms and production equipment;
- fragments are scattered, elements, details of the engine and production equipment as a result of cancellation of cylinders with compressed gas, separation of blades, explosion of the engine;
- aviation equipment (AE), tools and materials for maintenance of power plants and their units;
- work on high-altitude parts of the aircraft (over 1,3 m.);
- increased air velocity (more 12 m/s.);
- increased level of electrical statics during maintenance of aircraft (for example, the accumulation of static electricity takes place as a result of refueling the aircraft with fuel);
- acute edges, burrs and roughness on tool and equipment surfaces;
- protruding parts of the airplane and equipment;
- machines, mechanisms and their moving parts vehicles (self-propelled and non-self-propelled carts) for delivery to and from aircraft engines, aggregates, equipment;
- increased voltage 380/220V in the electrical circuit, the closure of which can pass through the human body;
- branched parts of the vessels working under pressure;

- increased slip (when icing, moistening, oiling);
- dynamic interaction of jets of fuel and oil materials and special oils under pressure;
- increased gas pollution of the working area air with vapors of fuel and oils that are spilled and displaced from the tanks of aircraft that are refueled;
- increased moisture content in the air;
- increased air mobility from the action of moving jets of aircraft gases and air flows, suction, which move at an increased speed (the zone of air intakes of engines);
- physical overload when maintenance units of power plants located in hard-to-reach places;
- jets of exhaust gases with high speeds when starting and testing engines, objects, soil particles, stones, sand, falling into these jets;
- an increased level of infrared radiation from the hot parts of the engine;
- increased levels of ultraviolet and thermal radiation during welding on the engine;
- chemicals that are part of the materials used (primers, sealants, adhesives, solvents, spirits, varnishes and paints);
- fuel and oil materials (kerosene, gasoline, gas, mineral and synthetic oils), harmful products of combustion of fuels, special liquids (AOH-10, NGF-4, liquid “И”, additives, washing liquids), that penetrate into the organism through the respiratory system, gastrointestinal tract, skin and mucous membranes;
- highly flammable fuel and oil materials;
- high or low ambient temperatures, aircraft units.

During the maintenance process, the above factors can lead to occupational diseases and injuries.

Permissible levels of hazardous and harmful production factors, as well as measures aimed at eliminating and reducing their impact on workers, are given in state standard «ГСТ 12.0.003-74».

5.2 Technical and organizational measures to reduce the impact of hazardous and harmful production factors

To eliminate or reduce the impact of hazardous and harmful production factors in accordance with the requirements of «Safety of work during maintenance and repair» developed the following measures:

- to eliminate injuries from unprotected moving parts of the aircraft, the stopping places are equipped with signs in accordance with state standard «ДСТ 12.4.026-76»;

- to protect personnel from aircraft, self-propelled installations during their movement, the following measures are provided:

- special hiking trails;

- special vehicles and self-propelled means of mechanization drive up and stop near the aircraft in accordance with the rules and schemes, which are listed in «Guide to the organization of the movement of aircraft and means of mechanization»;

- the speed of special vehicles on the platform is not more 20 km./h.;

- at the entrance to the serviced aircraft, before reaching it 10 meters, the driver stops the car and begins to move at a speed of not more than 5 km/h. under the direction of the official currently in charge of the aircraft;

- when working in tanks-caissons are used personal means of protection of respiratory organs (respirator, gas mask);

- when working inside the fuel tanks-caissons should appoint a team of at least three people familiar with the safety rules when working inside the fuel tanks. The crew can perform work only in one tank and only on the map-order. One of the crew members should be outside the tank for assistance, in case of need to evacuate the workers inside the tank;

- when working on lifting devices safety belts are attached to specially designed for this purpose on lifting devices safety knots;

- for the organization of stopping places are designed thrust pads to eliminate the movement of the aircraft during a stop. 6 thrust pads are applied to

the aircraft. The thrust pad is applied to the wheel and is a box shaped housing with steel cone pins mounted in it for thrust. To pick up the pads from under the wheels, it is recommended to use a special lifting device consisting of a lever, handle, wheels, lock and bolt-axis. The lock provides locking lever in two positions: installation on the spikes, rolling pads. This device is aimed at eliminating the rapid wear of the spikes during the pickup from under the wheels of the pads;

- specially designed stepladders with a height limit of 1 m are provided to eliminate falls during maintenance of high-placed engines;

- when working on high-placed parts of the engine and on the wing, a universal ladder is offered, designed for 150 kg. The ladder consists of two halves connected by a hinge. For fixing in working position in the case of the working platform there is a notch. Spikes are provided on the platform to prevent slipping. Stairs have perforated holes. The ladder has a handrail with a limiting contour on the working platform. Tools and equipment are placed on the ladders in special places to prevent them from falling and injuring personnel;

- to eliminate increased pollution, stopping places are periodically cleaned of dirt, snow, ice,, it is also provided for the use of special protected shoes by the service personnel;

- to reduce the noise level from the working engines and the impact of exhaust air and gas jets on the staff, testing of engines is carried out on special sites equipped with devices to keep the aircraft from shifting, noise reduction and shields, diverting the exhaust jet;

- before the race of the engine and testing of reversing devices is watering the launch site with water in order to eliminate increased dust formation;

- in order to reduce the impact of noise from the running engine if necessary to check the tightness of the fuel system provides for the use of maintenance personnel anti-noise liners;

- to eliminate overcooling or overheating of personnel, special rooms are provided for periodic stay of employees in them, as well as the use of overalls and personal protective equipment;

– to eliminate the disease of the visual organs in conditions of insufficient lighting, the use of individual portable lighting means with a voltage of 12, 27V is provided;

– in order to protect workers from electric shock the installation and dismantling of units and assemblies carried out previously disconnected the voltage from the consumption and hanging on the starting devices warning sign: «Not include,, working people!»;

– in order to reduce the toxic effect of kerosene fumes during work it is provided for the mandatory use of personal respiratory protection;

– fuel draining from the fuel tanks of aircraft must be carried out in accordance with the technical instructions for draining fuel from the tanks for this type of aircraft;

– manual movement means of filling with fuel-oil materials and other goods in the areas of refueling must be carried out in accordance with the requirements of «ДСТ 12.3.020-80». In the process of refueling under the wheels of the refueling means thrust pads are installed;

– to protect against static electricity, electrostatic grounding is used – the removal of charges into the ground with the help of electrostatic grounding of equipment. The latter is considered to be electrostatically grounded if the grounding resistance does not exceed 106 Om.

According to GOST 12.4.124-83 «Protection against static electricity» $R_{g.st} = 100 \text{ Om}$ is accepted as the permissible value of the ground resistance in the case when used exclusively for protection against static electricity. The same value is taken as the permissible resistance of the stationary grounding device in the parking lot. This device is connected to the means of centralized refueling of aircraft.

Organizational measures aimed at reducing the level of exposure to hazardous and harmful production factors are listed below.

The application of the maintenance strategy on the technical condition allows you to operate the aircraft product to the before-refusal state. This

significantly reduces the amount of work, because the replacement of engine units, their disassembly and defects will be made only after reaching any of the controlled parameters of the limit value.

To perform maintenance work are allowed workers who have been instructed, trained and tested knowledge on labor protection, fire and explosion safety, and first aid.

Training on labor protection of engineers and technicians are approved programs twice a year – during the transition to autumn-winter and spring-summer navigation maintenance of specific types of engines.

Workers performing maintenance should study dangerous and harmful production factors and rules of safe movement of passengers, engineering and technical personnel, aircraft, mechanization and special vehicles on the airfield.

Every three years, all managers and engineers are trained and certified for occupational safety in accordance with the «Regulations on the procedure for checking the knowledge of rules, norms and instructions on safety management and engineering workers» according to the approved programs.

Maintenance personnel must undergo preliminary and periodic medical examinations.

Persons who perform cleaning, cleaning and preventive disinfection and degassing must undergo special training and instruction on labor protection.

The personnel during performance of works on maintenance shall remove from themselves subjects of decoration items which it can catch on the acting parts of the equipment and units.

Control of temperature, humidity, air mobility and the content of dust and harmful substances in the workplace and in the working area is made in accordance with «ДСТ 12.1.005-76, ДСТ 12.1.007-76, ДСТ 12.1.014-79».

Measurement of noise level at workplaces is carried out once a year in accordance with the requirements of «ДСТ 20445-75».

Noise characteristics are measured by the method established «ДСТ 12.1.026-80».

Vibration measurement of machinery and equipment is carried out according to the methodology set out in «ДСТ 13731-68, ДСТ 12.4.012-83».

Periodic control of compliance of products of aviation technology with safety requirements is carried out in accordance with «ДСТ 15.001-73».

5.3 Fire and explosion safety during maintenance the power plant of the aircraft

When servicing the aircraft powerplant and the aircraft as a whole before a fire or explosion, the following factors may result:

- spillage of fuel on the ground when refueling;
- damage to the metallization, the occurrence of electric charges, when refueling the aircraft;
- violations (exceeding) the speed of refueling.

Dangerous in the fire relation on the plane are:

- fuel tank;
- power plant compartments;
- rear and front technical compartments;
- generator panels;
- area of laying of pipelines of removal of hot air;
- luggage compartment.

In accordance with «ДСТ 12.1.004-91» fire safety of the aircraft is provided by the fire protection system.

One of the most fire-hazardous objects of civil aviation enterprises is the hangars of aviation technical bases and repair buildings of repair plants, which are designed for maintenance and repair of aircraft.

Structural and planning solutions of hangars, as well as the degree of their fire resistance may be different depending on the type of repaired or serviced aircraft.

Modern hangars are buildings that have a medium one-storey part of the light type, as well as an attached part that has several floors and is designed to accommodate various support services of the aviation technical base.

Degree of fire resistance of the building – II. The class of functional fire hazard – Ф5.1. Such hangars can be quite significant in size, and their height can exceed 30 m. The coating of hangars lies in the Central part of the structure on metal or reinforced concrete spatial trusses. The front side of the hangar is a sliding gate consisting of several sections along the entire length and height of the repair part. These gates are driven by special electric motors powered by two independent feeders.

Hangars of aviation technical bases and aircraft repair buildings should be provided:

- fire horns with trunks and sleeves;
- blocking curtains, lowering, and water spray system, included automatically;
- defoaming system with stationary foam generators;
- stationary foam fire extinguishers;
- portable foam generators and manual fire extinguishers.

The main fire danger of hangars is a significant amount of flammable liquids (flushing and painting materials, non-fuel residue of aviation fuel, which reaches up to 1000 kg on some aircraft), rubber products and other combustible materials.

Practice shows that due to the presence of a high specific fire hazard, with the main gates of hangars closed after 18-20 minutes from the beginning of combustion, the concentration of highly toxic substances and the density of flue gases reach the limit values for people who do not have individual means of respiratory protection. The high density of smoke creates certain difficulties in the organization and conduct of evacuation and rescue operations. In the absence of thermal protection bearing metal trusses their collapse can occur as early as 20 minutes after the start of the fire.

Given the above, you need to take very seriously the choice of the method of protection of hangars. In Soviet times, the Ministry of civil aviation approved «Recommendations for the design of automatic foam fire extinguishing systems in modern hangars» (issued 21.08.1978 year). It seems like a long time ago, but they are relevant today. The recommendations apply to the design of automatic foam fire extinguishing systems.

The main points of the recommendations are as follows:

1. The fire extinguishing system can be unified for the entire hangar or divided into sections. A section is considered to be a part of the hangar that falls to the share of one aircraft.

2. Installation of fire extinguishing shall provide simultaneous and uniform supply of air-mechanical foam from above on the plane and on the floor area of the fire section not covered by it, and also from below on the lower surfaces of the plane.

3. The fire extinguishing system must be equipped with devices for remote start. Remote start can be carried out from the control room, from the fire department, as well as from the boards installed in safe places within sight of the protected section.

4. The estimated duration of extinguishing one fire-10 minutes, after that the installation can be disabled manually.

5. The intensity of feeding of foam solution is different for each aircraft type, different to supply on top of the plane, on top of the area of the hangar, bottom plane, but does not exceed $0,16 \text{ l/s m}^2$. Calculated area – the area of the horizontal projection multiplied by 1,5.

6. Flame sensors are used as fire detection devices.

In accordance with the requirements of automatic fire extinguishing systems should be designed taking into account the regulations in force in this area, as well as the construction features of buildings, protected areas and structures, the possibility and conditions of use of fire extinguishing agents based on the nature of the production process. Installation type extinguishing, method of extinguishing,

the view of the extinguishing substance (ES) is determined by the designer taking into account fire hazard and physico-chemical properties of the produced, stored and used substances and materials, as well as features of the protected equipment. Fire extinguishing installations should not contain «dead zones», are not exposed to ES.

To extinguish the hangars can be used sprinklers foam fire suppression system, deluge foam fire-fighting systems, gas extinguishing systems, installation of fire suppression systems robotic fire-extinguishing systems (RFS).

With the advent of RFI these installations for the protection of hangars began to be used most widely. This is due to technical capabilities that were not previously available to protect high-flying structures of large areas required for large fuselage aircraft.

Robotic fire extinguishing system (RFS) is a stationary automatic means, which is mounted on a fixed base, consisting of a fire barrel having several degrees of mobility, equipped with a system of drives, as well as a software control device.

Robotic fire complex (RFC) – a set of several RFS, united by a common control system and fire detection, which detect the coordinates of the fire, exchanging information between themselves and the analytical center, and carry out fire fighting throughout the declared working area.

The ignition detection device determines the angular coordinates of the ignition source. Each point of the protected room should be in the area of action of two trunks.

In RFC-RFS, when determining the coordinates of two observation points, data is obtained not only about the coordinates in space in a three-dimensional coordinate system, but also data on the distance to the hearth and the size of the hearth in height and width, which makes it possible to select the desired elevation angle and the fire extinguishing program.

RFS defines only angular coordinates of ignition which allow to use only direct aiming on the purpose. But, starting with 15m., you need to take into

account the ballistics of the jet and give an elevation angle, which at a range of 55 m. (at a flow rate of 20 l/s) is already 300°.

It should be noted that in accordance with the requirements, the average intensity of irrigation when scanning the area that is protected for RFC-RFS per cycle should be at least normalized for water fire extinguishing installations. According to this, the required consumption is determined for the groups of premises that are protected. RFC-RFS allows you to comply with these conditions and protect the premises within the minimum protected area with a given intensity of irrigation.

Each point of the protected room should be in the area of action of two trunks. Since RFC and RFS belong to automatic fire extinguishing systems, this rule should be observed automatically.

In RFC-RFS fire works stationary and forming both continuous, and the jet sprayed under the set angle of spraying. This allows you to more effectively extinguish fires. In RFC-RFS at distances up to 20 m. it is assumed to increase the angle of sawing up to 300°. There are technologies of fire extinguishing of a number of objects, where the spray angle is 1100°.

At least two barrels are involved in the fire extinguishing of the fire center. At distances from a trunk to the center of ignition less than 15 m. fire extinguishing is conducted with the set angle of sawing (it is specified in the project). At large distances, fire extinguishing is carried out by a compact jet over the area of the line jets. In the process of extinguishing, the barrel elevation angle is adjusted to take into account the jet ballistics depending on the pressure at the barrel outlet.

Cooling of building structures and aircraft located near the fire, it is recommended to carry out water supply from 2 fire robots in manual and remote modes.

As a fire extinguishing substance it is recommended to use:

- for elimination of possible centers of fire-foam of low multiplicity on the basis of an aqueous solution of the fluorinated foaming agent;

- for irrigation of load-bearing structures and equipment – sprayed water of gun carriage trunk.

Each point of the protected room must be in the range of at least two fire robots (FR) when placing them in two tiers, taking into account the irrigation maps.

The positioning of the FR should exclude extended «dead zones» for guidance sensors, as well as «dead zones» that are not affected by the extinguishing substance.

Location FR should not have obstacles to rotate in the horizontal and vertical planes taking into account the length of the barrel and the range of angles of movement.

The overlap of the irrigation zone FR should be at least 20% for each side.

The distance between the fire barrels of the RFC shall not exceed 80% of the maximum range of fire extinguishing agent supply at the established minimum operating pressure.

The FR should provide the possibility of simultaneous movement of the barrel with two degrees of mobility.

To detect a fire in the hangar should use sensors (detectors) flame.

Fire flame sensors are installed on the walls of the hangar in 2 levels:

- sensors installed at the lower level should provide control of the space under the aircraft;

- sensors installed on the upper level should provide control of the top of the aircraft;

- sensors installed on the lower and upper levels should provide control of the hangar area. Each point of the protected surface must be controlled by at least two flame sensors.

The signal of the fire detector «Attention» should be transmitted to the control room.

5.4 Calculation of the combustion chamber for explosion hazard

According to GOST 12.1.010-76 we will check the combustion chamber for explosion safety. When fuel vapors are formed in a confined space, an explosion can occur under certain conditions if there is a source of ignition, which is a fuel whose ignition temperature is 210 ... 250°C.

Upper limit of ignition:

$$V_B = \frac{p_B}{p_K} 100\% ,$$

де $p_B = 13332,2$ Pa – the vapor pressure of the fuel; $p_K^* = 2,24 \cdot 10^6$ Pa – air pressure behind the compressor.

$$V_B = \frac{13332,2}{2,24 \cdot 10^6} 100\% = 0,594\% .$$

Vapor concentration in the combustion chamber:

$$V_B = \frac{g_{\text{нал}}}{G_B} 100\% ,$$

де $g_f = 0,02$ kg.fuels /kg. air, the relative fuel consumption;

$$G_B = g_{\text{нал}} L_0 \alpha ,$$

де $L_0 = 12,58$ kg/s. – theoretically required amount of air

$$\alpha = \frac{1}{g_{\text{нал}} L_0} = \frac{1}{0,02 \cdot 14,9} = 3,36 ;$$

$$G_a = 0,02 \cdot 14,9 \cdot 3,36 = 1,001 \text{ kg. air/kg.fuels,}$$

$$V_{\text{кз}} = \frac{0,02}{1,001} 100\% = 2\% .$$

Given that $V_{\text{cc}} > V_a$ ($2 \geq 0,594$) the concentration of the fuel-air mixture is not explosive.

5.5 Safety instructions for maintenance of the aircraft power plant

Performance of maintenance of power plants of the aircraft should be carried out in accordance with the requirements «Safety rules for maintenance and repair of aircraft», instruction, maintenance regulations, aircraft operation manual and

other regulatory and technical documentation approved in accordance with the established procedure.

Maintenance of aircraft powerplants is allowed to start subject to the requirements of «OCT 54 71001-82» and after cooling the hot parts of the engine and its systems to the temperature set by the maintenance technology.

Maintenance of high-altitude engines must be carried out using specially designed ladders, ladders and lifting devices for this type of aircraft. Ladders used for maintenance must have a fence height of 1 meter.

Before performing work on the engine it is necessary to check the reliability of fixing the bonnet covers to prevent them from moving independently.

When performing repair work on highly located parts of the power plant (drilling, cleaning, riveting), workers should use safety belts. When working in the channels of the running part of the engine, the worker must have a safety halyard for evacuation from the channel if necessary. Starting and testing of the engine should be carried out only if other work on the aircraft is completed. In the area of leakage of the gas jet with the engine running should not be people, equipment and facilities. Dangerous are distance less 50 m. flushed in direction exit gases from engine and less 10 m. flushed before air intake engine. Starting and testing of the engine should be carried out only in the presence at the place of start of means of fire extinguishing according to requirements «ДСТ 12.1.004-76», «ДСТ 12.4.009-75».

Ladders and scaffolding from which work is carried out on engines with power tools must have an insulating coating in accordance with the requirements «ДСТ12.1.019-79».

Control of compliance with the requirements for maintenance of aircraft power plants must be carried out in accordance with the requirements of «Safety during maintenance and repair».

Conclusions to part 5

The analysis of dangerous and harmful production factors that occur during operation or repair of the power plant is made. Technical and organizational measures are provided to reduce the level of influence of dangerous and harmful production factors during operation or repair of the power plant. The analysis of explosion and fire hazard during maintenance of the power plant and the aircraft is made and the calculation of the combustion chamber of the designed engine for explosion hazard is carried out.

GENERAL CONCLUSION

The qualification work analyzes the basics of technical diagnostics, the basic concepts, terms and definitions are given. The main tasks of technical diagnostics as a field of knowledge covering the theory, methods and means of determining the technical condition of the object, including the engine of the aviation gas turbine, are also given. These tasks: the first is the definition of the technical condition in which the object was at some point in the past - the problems of the genesis; The second - to determine the technical condition of the object at a given point in time, which are called diagnostic tasks; Thirdly, these are the tasks of predicting the technical condition in which the object will be in the future. This type of task is important for predicting the remaining resource.

The qualifying work also provides general information about the turbojet engine D-436T1/T2, about the choice of the diagnostic object. A longitudinal section of the engine is given and it is indicated how the high efficiency of the engine is achieved. A brief description of the engine design is made.

Oil analysis is an important tool in any maintenance program, providing valuable information about the condition of the oil and, as a result, about the condition of the engine. To be the most effective, oil analysis should be used in the maintenance of the engine to take immediate effects in case of deviations. The oil analysis program reduces the risk of unexpected breakdowns and eliminates the costs associated with the downtime of the equipment.

The above oil analyzers (oil spectrometers) are a useful diagnostic tool that provide information in the shortest time. Fully automated measurements, diagnostic and cleaning systems allow any company to implement its own diagnostic program. This does not require special qualifications of personnel and special means of his work. Its main advantages are quick results for immediate decision -making and automation. Anyone can manage this tool. The analyzers have proven their ability to provide reliable data, which allowed the operators to make faster decisions with the results obtained in less than 15 minutes.

This work describes the study of online monitoring of the state of lubricating oil and forecasting the residual service life using the particle filtration method and commercially available online sensors from various existing world manufacturers.

The viscosity and dielectric constant are selected as working parameters for modeling the decomposition of lubricants. In particular, the evaluation of the characteristics of the lubricant and forecasting the remaining life of the degraded lubricant are presented using viscosity data and dielectric constant using particle filtration. An imitation study based on models confirmed in the laboratory is intended to demonstrate the effectiveness of the developed method.

An analysis of the basics and methods of laser vibrometry, as well as types of existing vibrations and vibration analyzers, was carried out. As a result, we can say that laser vibrometry differs from the traditional possibility of large measurements, high accuracy and reliability. A special advantage of laser vibrometry is associated with ease of measurement at many points of the object from the reduction (expansion) of the laser beam. Therefore, the scanning laser vibrometer allows you to create using the method of non -contact, the full vibration control of the object during real load during operation or in laboratory conditions to determine weak points or resonant points in the structure.

Non -contact methods of vibrometry are based on a comparison of controlled parameters with a wavelength of laser radiation. These methods are the most accurate compared to other measurement methods.

The influence of aircraft on environmental pollution and human health is analyzed. The listed composition of harmful substances emitted into the atmosphere by aircraft engines, and their analysis. Both constructive measures and organizational measures to reduce harmful emissions have been worked out. The engine of the aircraft according to its emission characteristics meets the standards of the ICAO.

The analysis of dangerous and harmful production factors that occur during operation or repair of the power plant is made. Technical and organizational measures are provided to reduce the level of influence of dangerous and harmful production factors during operation or repair of the power plant. The analysis of explosion and fire hazard during maintenance of the power plant and the aircraft is made and the calculation of the combustion chamber of the designed engine for explosion hazard is carried out.

LIST OF SOURCES USED

1. Машошин О.Ф. Диагностика авиационной техники. Учебное пособие – М.: МГТУ ГА, 2007 – 141 с.
2. Авиационные правила , часть 25. «Норми льотної придатності літаків транспортної категорії», 2014, – 278 с.
3. Положение о комплексной системе диагностирования изделий авиационной техники с применением обмена информации на этапах эксплуатации и ремонта. – М.: МГА, 1989.-121 с.
4. ГОСТ 20911-89 Техническая диагностика. Термины и определения.
5. ГОСТ 27.002-89 Надежность в технике. Термины и определения.
- 6.ГОСТ 19919-74 Контроль автоматизированный технического состояния изделий авиационной техники. Термины и определения.
7. Клюев, В.В. Технические средства диагностирования: справ. / В.В. Клюев, П.П. Пархоменко, В.Е. Абрамчук [и др.]; под общ. ред. В.В. Клюева. - М.: Машиностроение, 1989.
8. Киселев, Ю.В. Основы теории технической диагностики: учеб. пособие / Ю.В. Киселев; Самар, гос. ун-т. – Самара, 2004.
9. Киселев, Ю.В. Вибрационная диагностика систем и конструкций авиационной техники / Ю.В. Киселев, Д.Ю. Киселев, С.Н. Тиц. Учебник, Самара, Изд. СГАУ, 2012, –207 с.
10. Лозицкий, Л.П., Янко А.К., Лапшов В.Ф. Оценка технического состояния авиационных ГТД. / Л.П. Лозицкий, А.К. Янко, В.Ф. Лапшов. – М.: Воздушный транспорт, 1982.
11. Кулик М.С., Гвоздецький І.І., Ясиніцький Е.П. Системи автоматичного керування газотурбінних двигунів і газотурбінних установок. – К.: НАУ, 2017.-364с.
12. Теорія авіаційних газотурбінних двигунів: Підручник. / Під ред. Ю.М. Терещенка. – К.: Вища освіта, 2006. – 480 с

13. Васильев, В.И. Автоматический контроль и диагностика систем управления силовыми установками летательных аппаратов./ В.И. Васильев, Ю.М. Гусев, А.И. Иванов и др. – М.: Машиностроение, 1989.
14. <http://www.motorsich.com/files/90-D-436-148.pdf>
15. Двигатель Д-436 Т1/Т2. Руководство по технической эксплуатации.
16. Технические средства диагностирования. Справочник / Под общ. ред. В.В. Ключева. – М.: Машиностроение, 1989, – 672 с.
17. Авіаційні газотурбінні двигуни. / Під ред. Ю.М. Терещенка. – К.: КІ ВПС, 2001. – 310 с.
18. Кулик М.С., Гвоздецький І.І., Ясиніцький Е.П. Системи автоматичного керування газотурбінних двигунів і газотурбінних установок. – К.: НАУ, 2017.-364с.
19. Иноземцев, А.А. Газотурбинные двигатели. Автоматика и регулирование авиационных двигателей и энергетических установок. Системы. / А.А. Иноземцев, М.А. Нихамкин, В.Л. Сандрацкий. – М.: Машиностроение, 2007, – 196 с.
20. <http://www.sib-ndt.ru/equipment/optiko-emissionnyy-spektrometr-dlya-analiza-smazochnyh-masel-mfs-11/>
21. <http://granat-e.ru/microlab-40.html>
22. Елисеев, Ю.С. Технология эксплуатации, диагностики и ремонта газотурбинных двигателей. / Ю.С. Елисеев, В.В. Крымов, К.А. Малиновский, В.Г. Попов. Учебное пособие. – М.:Высшая школа, 2002. – 355 с.
23. Сиротин, Н.Н. Техническая диагностика авиационных газотурбинных двигателей. / Н.Н. Сиротин, Ю.М. Коровкин. М.: Машиностроение, 1972. – 272 с.
24. Bernhard Jakoby, Michiel J Vellekoop/ Physical sensors for water-in-oil emulsions/ Sensors and Actuators A: Physical, 2004/2/1, Pages 28-32.
25. Joel Schmitgal, S. Moyer / Evaluation of Sensors for On-Board Diesel Oil Condition Monitoring of U.S. Army Ground Equipment/ Engineering, 11 April 2005.

26. Raadnui, S. and Kleesuwan, S. Low Cost Condition Monitoring Sensor for Used Oil Analysis. *Wear*, 259,1502-1506, 2005.

27. Junda Zhu, David He, Eric Bechhoefer. Survey of lubrication oil condition monitoring, diagnostics, prognostics techniques and systems. January 2013.

28. Джигирей, В.С. Екологія та охорона навколишнього природного середовища. Навчальний посібник.: Т-во „Знання”, КОО, 2000.–205с.

29. Білявський, Г.О. Основи екологічних знань: Підручник. Г.О. Білявський, Р.С. Фурдій. – К.: Либідь, 1997. – 228 с.

30. Буриченко, Л.А. Охрана труда в гражданской авиации. Учебник для ВУЗов, Л.А. Буриченко – 3-е изд., перераб. и доп. – М.: Транспорт, 1993. – 288 с. – Для студентов вузов гражданской авиации, может быть полезен инженерно-техническим работникам авиапредприятий и лётному составу.

31. Протоерейський, О.С. Охорона праці: Практикум для студентів усіх спеціальностей. О.С. Протоерейський - К.: НАУ, 2001. - 82 с.