

**МІНІСТЕРСТВО ОСВІТИ І НАУКИ УКРАЇНИ  
НАЦІОНАЛЬНИЙ АВІАЦІЙНИЙ УНІВЕРСИТЕТ**

Кафедра конструкції літальних апаратів

**«ДОПУСТИТИ ДО ЗАХИСТУ»**

Завідувач кафедри  
д-р техн. наук., проф.

\_\_\_\_\_ С.Р.Ігнатович  
(підпис)

« \_\_\_\_\_ » \_\_\_\_\_ 2021 р.

# **ДИПЛОМНИЙ ПРОЕКТ**

**(ПОЯСНЮВАЛЬНА ЗАПИСКА)**

**ВИПУСКНИКА ОСВІТНЬО-КВАЛІФІКАЦІЙНОГО РІВНЯ**

**«БАКАЛАВР»**

**Тема: «Аванпроект дальньо магістрального пасажирського літака  
пасажиромісткістю 220 пасажирів»**

**Виконав:** \_\_\_\_\_ Жуйшен Цяо

**Керівник: д-р техн. наук., проф.** \_\_\_\_\_ М.В. Карускевич

**Нормоконтролер: канд. техн. наук., доц.** \_\_\_\_\_ С.В. Хижняк

**Київ 2021**

**MINISTRY OF EDUCATION AND SCIENCE OF UKRAINE**  
**NATIONAL AVIATION UNIVERSITY**  
Aircraft Design Department

APPROVED BY  
Head of department  
Professor, Dr. of Sc.  
\_\_\_\_\_ S.R. Ignatovych  
«\_\_\_» \_\_\_\_\_ 2021

**DIPLOMA WORK**

**(EXPLANATORY NOTE)**  
**OF EDUCATIONAL DEGREE**

**«BACHELOR»**

**Theme: «Preliminary design of long-range passenger aircraft with 220  
passenger capacity »**

**Performed by:** \_\_\_\_\_ Ruisheng Qiao

**Supervisor: Dr. of Science, Professor** \_\_\_\_\_ M. V. Karuskevich

**Standard controller: PhD, associate professor** \_\_\_\_\_ S.V. Khizhnyak

**Kyiv 2021**  
**NATIONAL AVIATION UNIVERSITY**

Aerospace Faculty

Aircraft Design Department

Educational degree «Bachelor»

Speciality 134 "Aviation and Space Rocket Technology"

APPROVED BY  
Head of department  
Professor, Dr. of Sc.  
\_\_\_\_\_ S.R. Ignatovych  
« \_\_\_\_ » \_\_\_\_\_ 2021

**TASK**  
**for bachelor diploma work**  
**RUI SHENG QIAO**

**1. Theme: «Preliminary design of long-range passenger aircraft with 220 passenger capacity»**

Confirmed by Rector's order from 21.05.2021 year №815/CT

**2. Period of work execution 24.05.2021 to 20.06.2021**

**3. Work initial data:**

- Maximum payload –  $n = 220$  passengers;
- Flight range with maximum payload –  $L = 7200$  km;
- Cruise speed –  $V_{cr} = 850$  km/h at operating altitude  $H_{op} = 11000$  m;
- Landing speed –  $V_{land} = 231.19$  km/h.

**4. Explanation notes (list of topics to be developed):**

- selection of design parameters;
- choice and substantiations of the airplane scheme;
- determination of basic geometrical parameters;
- aircraft layout;
- calculation of aircraft masses;
- center of gravity position calculation;
- determination of basic flight performance;

- description of the aircraft design;
- engine selection;
- tyre selection;
- special part.

**5. List of the graphical materials:**

- general view of the airplane (A1×1);
- layout of the airplane (A1×1);
- ball mat general drawing (A1×1);
- assembly drawing of the ball mat (A1×1).

**6. Calendar Plan**

№	Task	Execution period	Signature
1	Task receiving, processing of statistical data	24.05.21- 26.05.21	
2	Aircraft take-off mass determination	27.05.21- 28.05.21	
3	Aircraft layout	29.05.21- 30.05.21	
4	Aircraft centering determination	31.05.21- 01.06.21	
5	Graphical design of the parts	02.06.21- 05.06.21	
6	Completion of the explanation note	06.06.21- 07.06.21	
7	Preliminary defence	08.06.21- 09.06.21	

**7. Task issuance date: 24.05.2021**

Supervisor of diploma work: \_\_\_\_\_  
(signature)

M.V. Karuskevich

Task is given for: \_\_\_\_\_  
(signature)

Жуйшен Цяо

## ABSTRACT

Explanatory note to the diploma work «Preliminary design of long-range passenger aircraft with 220 passenger capacity» contains:

58 pages, 19 figures, 15 tables, 16 references and 4 drawings

Object of the design is development of passenger long-range aircraft with 220 passenger capacity.

Aim of the diploma work is the preliminary design of the aircraft and its design characteristic estimation.

The methods of design are analysis of the prototypes and synthesis of the most advanced technical decisions, calculations according to the approved procedures, drawing according to the current computer aided design methods.

The diploma work contains drawings of passenger long-range aircraft with 220 passenger capacity, calculations and drawings of the aircraft layout, ball mat concept, calculations and drawing.

**AIRCRAFT, PRELIMINARY DESIGN, LAYOUT, CENTER OF GRAVITY POSITION, BALL MAT.**

NAU 21 19Q 00 00 46

				NAU 21 19Q 00 00 46			
<i>Performed by</i>	<i>Qiao Ruisheng.</i>			ABSTRACT	<i>Letter</i>	<i>Sheet</i>	<i>Sheets</i>
<i>Supervisor</i>	<i>Karuskevich M.V.</i>						
<i>Adviser</i>							
<i>Stand.contr.</i>	<i>Khizhnyak S.</i>						
<i>Head of dep.</i>	<i>Ignatovych S.</i>						
					402 AF 134		

## CONTENT

<b>Introduction</b> .....	9
<b>PART 1. PRELIMINARY DESIGN OF THE PLANE</b> .....	11
1.1. Analysis of similar planes.....	11
1.2. New plane description.....	13
1.2.1. Wing.....	15
1.2.2. Tail Unit.....	16
1.2.3. Power Plant.....	16
1.2.4. Landing Gear.....	16
1.2.5. Flight Control System.....	17
1.2.6. Crew cabin.....	18
1.3. Geometry calculation of the new aircraft parameters.....	18
1.3.1. Wing geometry calculation.....	18
1.3.2. Fuselage layout.....	21
1.3.3. Luggage compartment.....	24
1.3.4. Galley.....	25
1.3.5. Lavatory.....	25
1.3.6. Calculation of basic parameters of tail unit.....	25
1.3.7. Landing gear design.....	27
1.3.8. Power Plant.....	29
1.4. Calculation of the C.G of the aircraft.....	29
1.4.1. Calculation of centering of the equipped wing.....	30
1.4.2. Calculation of centering of the equipped fuselage.....	31
Conclusion to the part 1.....	34
<b>PART 2. BALL MAT DESIGN</b> .....	35
2.1. Introduction.....	35

NAU 21 19Q 00 00 46			
<i>Performed by</i>	<i>Qiao Ruisheng.</i>		
<i>Supervisor</i>	<i>Karuskevich M.V.</i>		
<i>Adviser</i>			
<i>Stand.contr.</i>	<i>Khizhnyak S.</i>		
<i>Head of dep.</i>	<i>Ignatovych S.</i>		

CONTENT	Letter	Sheet	Sheets
402 AF 134			

2.2. The dimensions of the Cargo Hold or Containers Compartment.....	36
2.3. The dimensions of the Ball Mat module.....	42
2.4. The material for the Ball Mat module and Ball Unit.....	44
2.5. Ball Unit modelling and Analysis.....	47
Conclusion to part 2.....	50
<b>General Conclusion.....</b>	<b>51</b>
References.....	52
Appendix A.....	53
Appendix B.....	56
Appendix C.....	57

				<i>NAU 21 19Q 00 00 46</i>			
<i>Performed by</i>	<i>Qiao Ruisheng.</i>			<b>CONTENT</b>	<i>Letter</i>	<i>Sheet</i>	<i>Sheets</i>
<i>Supervisor</i>	<i>Karuskevich M.V.</i>						
<i>Adviser</i>					<i>402 AF 134</i>		
<i>Stand.contr.</i>	<i>Khizhnyak S.</i>						
<i>Head of dep.</i>	<i>Ignatovych S.</i>						

## LIST OF ABBREVIATIONS

AFT	Aftward
APU	Auxiliary power unit
BM	Ball mat
CC	Cargo compartment
CG	Center of gravity
CL	Coefficient of lift
CLS	Cargo loading system
CM	Center of mass
EASA	European Aviation Safety Agency
ECAM	Electronic Centralized Aircraft Monitor
ECS	Environment Control System
EICAS	Engine Indication and Crew Alerting System
FAA	Federal Aviation Administration
Fly-by-wire	FBW
FWD	Forward
LG	Landing gear
LRA	Long-range airplane
MAC	Mean aerodynamic chord
TLG	Tricycle landing gear with front single-strut and two main gears
ULD	Unit load device
BM	Ball Mat



## List of drawings

<b>№</b>	<b>Name of drawings</b>	<b>Format</b>	<b>Number of sheets</b>
1	General view of passenger aircraft	A1	1
2	Layout of the passenger aircraft	A1	1
3	Ball mat general drawing	A1	1
4	Ball mat assembly drawing	A1	1



## Introduction

With the fast development of economy and technology in the world, the communication between countries becomes more common. We can observe the increasing of the volume of passenger traffic. And another contributing factor is that advanced materials can decrease the aircraft weight, improve the structural efficiency of aircraft and make it more comfortable. However, the global context of epidemic, dramatically decreased the amount of passengers and the need for large passenger aircrafts. In this consideration there is a need for middle capacity passenger planes to transport for long ranges. This category of planes is expected to be demanded nearest years.

There are some requirements give the general idea to create a new aircraft:

- Functional requirements;
- technical requirements;
- performance requirements;
- manufacturing requirements;
- operational requirements;
- technical and economic requirements.

To ensure beneficial aviation technology operations in a globally competitive market and guarantee high schedule reliability and regularity of flights, newly developed planes should meet the requirements of the international organization of air transport:

- Safety and regularity of flight;
- performances;
- reducing emissions of harmful gases and be more environmental;
- comfort;

- reliability and maintenance;
- high efficiency and competitiveness;
- the airplane low cost and long lifespan.

The purpose of this diploma paper is to create an aircraft intended for the carriage of 220 passengers for long distance ranges.

The major prototype of this project is Airbus 321neo. The aircraft is a narrow-body, low-wing construction with a conventional tail unit and powered by CFM International's LEAP-1A engines with max take-off thrust of 143.05 kN each one, which installed under the wing. The engine is twin spool high bypass turbofan engine. The wing fitted with sharklets to decrease the induced drag, which 15% to 20% more fuel efficient than the aircraft without. The aircraft is also along with reduced noise and CO<sub>2</sub> emissions.

Since the Wright Brothers firstly achieved to controll flight of a manned flying machine, people never stop the step of explore the mystery of aviation. With the persistent advancement of science, the future of aircraft will be more dependent on multinational efforts. The aircraft trend is eco-friendly, faster and less cost.

The project reflects the demand on international commercial transportation. There is still a great demand in the market for aircraft with comparatively long range and adequate payload. Also, such aircraft must be reliable, especially in take-off and landing conditions.

The special part of the work deals with ball mat preliminary design. The application of ball mat makes the transportation of ULDs more convenient and reduce turnaround time.

The geometry of the ball mat panels has been found. The ball transfer units are analysed and have been selected for the designed aircraft. Key calculations of the ball mat supply the project.

# PART 1

## PRELIMINARY DESIGN OF THE PLANE

### 1.1. Analysis of similar planes

Choosing the best design parameters for an aircraft is a complex problem and requires a number of optimization tasks in multiple aspects. It includes numerous aspects: geometrical, aerodynamic, flight-technical and economic characteristics, etc. In the design process, firstly we used statistical information, empirical formulas and methods then use a full aerodynamic calculation and analysis, including doing some experiments to get the factual and primary data.

When selecting the design parameters of the aircraft, it is essential to apply some already achieved technology, which means using the main features and parameters of the prototype aircraft.

The shape and layout of the aircraft influence the aerodynamic properties and center of gravity. Payload determines the fuselage size and shape and leads into landing gear design, depending on wing and engine positioning, while wing design largely determines the range, operational envelope, and field performance objectives [1]. All together, the configuration of the aircraft may be changed, and there is likely to be more than one alternative configuration.

Prototypes of the aircraft taking for the designing aircraft are in class 200-240 passengers, about 7000 km flight range and have other advantages such as economic efficiency, enviromental protection. For the preliminary design, I have selected these planes as prototype: Airbus 321neo, Airbus 320neo and Boeing 737max9.

The basic technical and functional data of prototypes are shown below in table 1.1.

Table 1.1 - Basic technical and functional data of prototypes

PARAMETER	PLANES		
	A321neo	A320neo	B737max9
The type of airplane	Passenger	Passenger	Passenger
Crew/flight attendant	2/6	2/5	2/5
Maximum take-off weight, $m_{tow}$ , kg	97000	79000	88314
Passenger's seat	240	195	193
The height of the flight $H_f$ , m	12100	12100	12000
Most pay-load, $m_{c,max}$ , kg	25500	20000	20882
Range $m_{k,max}$ , km	7400	6500	6570
Take off distance L, m	1988	1951	2600
Landing distance, m	1600	1600	1700
Cruising speed, V, km/h	828	828	839
Number and type of engines	2×CFM International LEAP-1A	2× Pratt & Whitney PW1100G	2×CFM International LEAP-1B
Thrust of each engine, KN	160	160	130
Pressure ratio	50	50	40
Bypass ratio	12.5	12.5	9
Landing gear scheme	TLG	TLG	TLG
Length of aircraft, m	44.51	37.57	42.16
Height of aircraft, m	11.76	11.76	12.3
Diameter of fuselage, m	3.95	3.95	3.76
Wingspan, m	35.80	35.80	35.92
Wing aspect ratio	9.390	9.390	9.442
Wing taper ratio	0.240	0.240	0.278
Wing sweepback on 1/4 chord, °	25	25	25

Before selecting the designed aircraft scheme, the prototypes' scheme is studied and analyzed. The table above shows the basic parameters and provides the possibility to select the great characteristics for the new aircraft.

To substantiate the project, the following tasks have been solved:

- Wing geometry calculation, as well as the tail unit;
- fuselage layout;
- basic parameters and position of landing gear;
- type of engines;
- calculation of the aircraft center of gravity position.

## **1.2. New plane description**

In conformity with our task, a passenger aircraft is designed, which carries 220 passengers on long range. The special part deals with the ball mat for use to facilitate loading of containers and pallets.

Here I have chosen A321neo as main prototype because of its relatively great characteristics, good fuel efficiency and flight endurance, which meet our requirements to carry passengers for international transportation and reduce the pollution. The "neo" indicates the new turbofan engines (PW 1100G or CFM LEAP-1A) used in the aircraft. The A321neo completed successfully a rigorous certification program that tested its airframe and systems well beyond their design limits to ensure that the aircraft successfully met the highest safety standards set by EASA for Europe [2].

The basic design goal for this aircraft is to carry 220 passengers at a range of 7200 kilometers with a cruising speed of 850 km/h and an altitude of 11000 meters.

The prototype is made as a low-wing monoplane with two high bypass turbofan engines, combined with the improvements of airframes. In addition, it particularly uses new engines and a new kind of wingtips, known as the "sharklets" in Airbus. The sidestick controller is located on the side console of each pilot, which is

equipped with FBW control systems. The wing has sweepback angle on  $\frac{1}{4}$  chord equal to  $25^\circ$ .

The pressurized fuselage is circular section and semi-monocoque construction, which is characterized by the skin, strengthened by stringers, longitudinal beams and frames. The fuselage is mainly constructed with alclad alloys of aluminum, forming a strong and rigid framework to withstand internal pressure.



Figure 1.1 – General view of A321neo

To decrease the weight of the aircraft, increase the structure strength and reduce the cost, nowadays composite and advanced materials or alloys are widely used, such as oriented organic glass, polystyrene, fiberglass, polyamide resins, polyethylene, fluoroplastic, etc. Composite materials have been used in the vertical stabilizer, horizontal tail, rudder, forward fuselage and other components on the modern passenger aircraft.

The fuselage has a two-cabin layout, which one is business class, the other one is economy class. There are two emergency exits located on each side for emergency evacuation. Along the cabin on each side, there are luggage racks for accommodating passengers' personal luggage. Under the floor of the fuselage, the cargo compartments are located which store containers, pallets and luggages. The Environment Control System (ECS) controls and monitors the air quality, temperature and pressure, also ensures that the airflow inside the cabin is constantly moving to provide a good ventilation [3].

### 1.2.1. Wing

The wing is streamline shaped and swept-back, which dramatically decrease the drag and increase the critical mach number. The dihedral angle of the wing can increase the lateral stability of the aircraft. When the aircraft immersed in water, low wing can also give the fuselage additional buoyancy.

A wing designed for efficient high-speed flight is often quite different from one designed solely for take-off and landing [4]. The wing has high-lift devices, such as flaps, slats and ailerons, increasing the lift, thus improving the takeoff and landing performance and maneuverability of the airplane. However, usage of these high lift devices also has its own disadvantages, such as increasing drag. The spoiler is a hinged rectangular plate typically arranged on the upper surface of the wing and the front edge of the flap. During flight, pilots can use flight spoilers to control the roll to improve the control efficiency and use flaps and ground spoilers to increase the drag to enhance the aerodynamic brake effect and reduce wheel brake wear during landing.

The wing structure consists of front spar, rear spar, rib, stringers and skin. They are the main structural members and take the most of loads. The spar carries the flight loads and the wing weight due to gravity when it is on the ground. The stringers used to resist axial and bending loads and transmit the aerodynamic forces from the skin to the ribs. As for rib, it creates the shape of the cross-section of the wing and distributes concentrated loads into the structure. The skin of the wing has diverse thicknesses at different locations, it changes from the maximum at the root of the wing to the minimum at the tip of the wing. It mainly forms surface for supporting the aerodynamic pressure distribution and transmits aerodynamic forces.

Moreover, the wing is an integrated component for the storage of fuel for the engine. Different types of fuel tanks are located in different locations to provide respective functions. Fuel can flow from any tank to any engine through the cross-feed system.



### 1.2.2. Tail Unit

For the conventional aircraft, it usually has the tail which includes horizontal tail and vertical tail carries these primary functions: trim, stability and control for longitudinal and directional direction. When a two-engines aircraft fail one engine, pilots can control the rudder to generate yawing moment to balance the aircraft.

In order to maintain the same aerodynamic load characteristics, the profiles of the vertical and horizontal units are designed and manufactured to be symmetrical.

The swept angle of horizontal tail and vertical tail is  $29^\circ$  and  $34^\circ$  correspondingly, which both of them are greater than the sweep of the wing to prevent the lost of the aircraft contralability at high speed.

### 1.2.3. Power Plant

The power plant consists of two turbofan engines and APU. The engines are installed in nacelles, attached under the wing by pylons. Fuel stores in the wing tanks and fuselage tanks. Considering of the safety, engine installment needs to remain enough distance from fuselage and there is a dry bay in the fuel tank to avoid explosion.

Engine is the heart of the aircraft. Usually, using two engines can improve the safety in case of one engine fails. There are many components mounted on the engine: propeller, cowl, vortex control device, accessory gear box, fuel system and fire extinguishing system, etc. The core of engine includes compressor, combustor and turbine. Thrust reverser often used to change the direction of airflow to decrease the speed while landing.

Generally, APU is located at the rear end of the fuselage which generates 115 Volts AC at 400 Hz to operate the aircraft's electrical system through a three-phase system. Work of the engines and APU can be monitored by pilots in EICAS.

#### 1.2.4. Landing Gear

Landing gear is used for keeping the aircraft stable on the ground, allowing the aircraft to freely move and operate during taxiing, providing a safe distance between the ground and the aircraft, and absorbing the shocks energy during landing. The aircraft has a retractable tricycle landing gear configuration operated by hydraulic system.

The main gears are installed in the nacelles and retracted into wheel well during flight. Each one main landing gear has four wheels and has hydraulic brake system. Main gear carries about 80% to 95% of the aircraft load. But the nose gear has two wheels and generally nose wheel is smaller than the main wheel.

Retractable landing gears reduce the drag, which can increase the speed, range of flight and decrease fuel consumption. The aircraft use the hydraulic system to control the landing gear. To make sure the airplane can keep the straight-line direction of movement during take-off and run, there are also a damper in the nose landing gear to prevent shimmy. In the event of a hydraulic system failure, the pilot can open the landing gear manually by using the mechanical system.

The landing gear design should meet these requirements: Ground controllability, Ground Stability and Structural Integrity.

#### 1.2.5. Flight Control System

Control of the aircraft is carried out by digital fly-by-wire system. The use of the on-board systems ensures that the aircraft are more reliable. The autopilot is both electrically and air-driven, providing a capability to fly the aircraft automatically and greatly reducing the workload of the aircrew.

Along with the development of new aircraft, the introduction of new technologies abounds and the pace of system integration at the aircraft and subsystem levels using avionics is increasing [5]. The aircraft control system controls: elevator, stabilizers, rudder, ailerons, flaps, slats and spoilers.

When the system detects an error, warning messages will be displayed on the ECAM display and activate the corresponding warning lights to illuminate and audio warning sounds.

#### 1.2.6. Crew cabin

The cockpit provides basic conditions for the flight crews to work and rest. There are five windows in total which provide a good perspective and equipped sun shield. The crew consists of the captain and first officer. Captain is responsible for everything and everyone on board. The captain's seat is located on the left side and the first-officer's seat is located on the right side. There is also a manually operated seat for observer or used for additional crew members, if necessary. Pilots use keyboard and sidestick controller located on the outboard side to control and command.

The cockpit is separated from aircraft cabin by a door. There is also an emergency exit and some other emergency instruments for pilots, such as fire extinguisher, life vest and oxygen mask, etc.

### 1.3. Geometry calculation of the new aircraft parameters

During the aircraft design process, the aircraft designer has many tasks to solve. One of the most important tasks is to design an efficient wing complying with the determined requirements which are generally possible with optimizing so many geometrical and aerodynamic parameters of the wing [6].

#### 1.3.1. Wing geometry calculation

First of all, we can calculate the full wing area by the take off weight  $m_0$  and the wing loading  $P_0$ . Here is the formula:

$$S_w = \frac{m_0 \cdot g}{P_0} = \frac{116422 \times 9,8}{5557} \approx 205.32 \text{ (m}^2\text{)}.$$

Relative wing extensions area percentage is 0.05.

Wing area is:

$$S_w = 205.32 \times (1 - 0.05) \approx 195.054 \text{ (m}^2\text{)}.$$

Almost all modern high-speed aircraft have sweepback wings. Sweepback is the angle between the  $\frac{1}{4}$  of the chord line of the wing and perpendicular to the longitudinal centre line of the aircraft [7]. The sweepback angle of this plane is  $25^\circ$ .

Refer to the prototype, I take the value of aspect ratio 9.4.

Wing span is:

$$l_w = \sqrt{S_w \cdot \lambda} = \sqrt{195.054 \times 9.4} \approx 42.82 \text{ (m)},$$

where  $\lambda$ - aspect ratio.

The larger the aspect ratio of the wing, the higher the aerodynamic efficiency of the wing.

Root chord is:

$$b_o = \frac{2S_w \cdot \eta_w}{(1 + \eta_w) \cdot l_w} = \frac{2 \times 195.054 \cdot 4.11}{(1 + 4.11) \times 42.82} = 7.328 \text{ (m)},$$

where  $\eta_w$  – taper ratio.

Tip chord is:

$$b_t = \frac{b_o}{\eta_w} = \frac{7.328}{4.11} = 1.783 \text{ (m)}.$$

Maximum wing thickness is equal to:

$$c_i = c_w \cdot b_t = 0.12 \times 1.783 = 0.214 \text{ (m)}.$$

Onboard chord is equal to:

$$b_{ob} = b_o \cdot \left(1 - \frac{(\eta_w - 1) \cdot D_f}{\eta_w \cdot l_w}\right) = 7.328 \times \left(1 - \frac{(4.11 - 1) \times 3.95}{4.11 \times 42.82}\right) = 6.817 \text{ (m)}.$$

where  $D_f$  – the diameter of fuselage.

The effects of the taper ratio on wing aerodynamic parameters can be obtained by means of numerical or experimental analyses [8]. If root chord is larger (namely bigger taper ratio), the airplane fuel volume will increase and decrease the induced drag. Considering the minimum induced drag coefficient, wing-tip stall problem and referring to this prototype, I accepted take taper ratio value  $\eta_w = 4.11$ .

Thickness to chord (t/c) value is the ratio between the maximum thickness and chord. Higher thickness can increase lift. the thickness to chord value i selec equal to 0.12.

By using the geometrical method of mean aerodynamic chord determination (Figure 1.2), at last I got the value of the mean aerodynamic chord equal to  $b_{MAC}=5.11$  m.

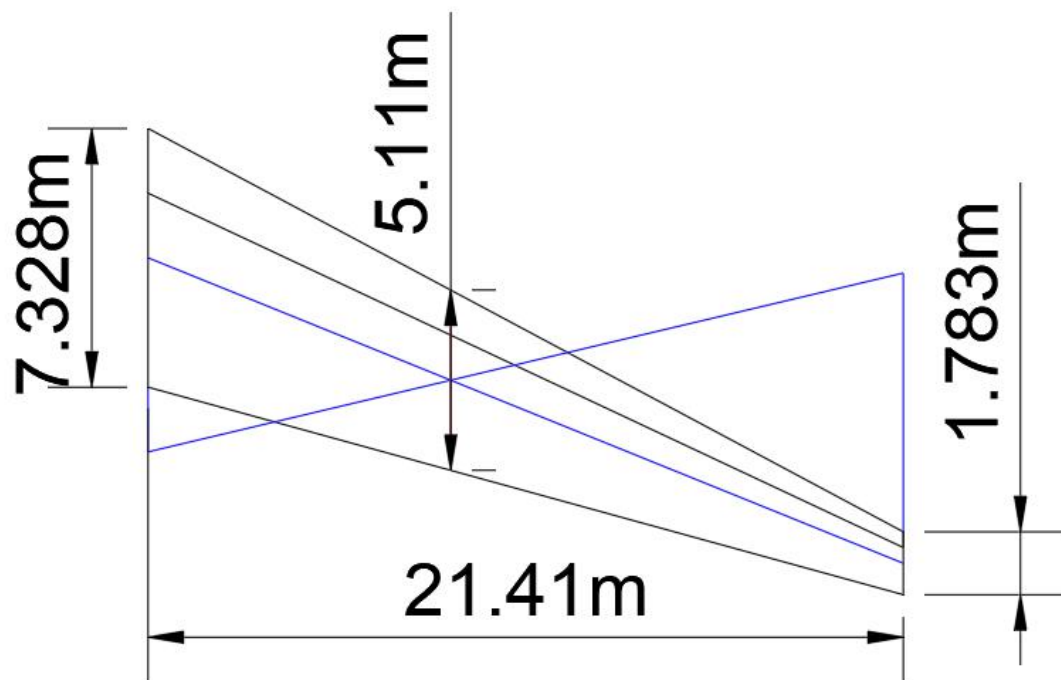

Figure 1.2 - Determination of mean aerodynamic chord

Ailerons geometrical parameters are determined in following steps:

Ailerons span:  $l_{ail} = (0.3 \sim 0.4) \cdot l_w / 2 = 0.35 \times 15.125 = 5.3$  (m).

Aileron chord:  $b_{ail} = (0.22 \sim 0.26) \cdot b_t = 0.24 \times 1.35 = 0.324$  (m).

Aileron area:  $S_{ail} = (0.05 \sim 0.08) \cdot S_w / 2 = 0.065 \times 40.25 = 2.62$  (m<sup>2</sup>).

Modern aircrafts trend to decrease relative wing span and ailerons area so we use flight spoilers together with the ailerons for the transversal (Roll) control.

The calculations of aerodynamic compensation of the aileron:

Axial compensation  $S_{axinail} \leq (0.25 \sim 0.28) \cdot S_{ail} = 0.265 \times 2.62 = 0.6943$ (m<sup>2</sup>).

Inner axial compensation  $S_{inaxinail} = (0.3 \sim 0.31) \cdot S_{ail} = 0.305 \times 2.62 = 0.8$ (m<sup>2</sup>).

The calculations of area of ailerons trim tab:

For two engine airplane:  $S_{tail} = (0.04 \sim 0.06) \cdot S_{ail} = 0.05 \times 2.62 = 0.131(m)$ .

In a word, the more effective system saves fuel through building a lighter wing with better lift-to-drag ratio than would be possible in the case of an overall design with a simple high lift system [9].

Here I use the two-slotted flap design, so the flap chord is:

$b_{ff} = (0.28 \sim 0.3) \cdot b_t = 0.29 \times 1.35 = 0.392 (m)$ .

During process of design, the rate of the relative chords of wing high-lift devices is shown in table 1.2

Table - 1.2 The rate of the different relative chords of wing high-lift devices

Type	The rate of the relative chords
The split edge flaps	0.25 ~ 0.3
one slotted and two slotted flaps	0.28 ~ 0.3
three slotted flaps and Faylers flaps	0.3 ~ 0.4
slats	0.1 ~ 0.15

When choosing the structural dynamic scheme, hinge-fitting scheme and kinematic scheme of the high-lift devices, we need to refer to the data and the experience of domestic and international aircraft manufacturing. We also need to notice the fact that in most of the existing structures, the components of the high-lift device are completed by means of a support structure scheme.

### 1.3.2. Fuselage Layout

In conventional aircraft the role of fuselage is to hold the payload. The payload of passenger aircraft consists of passengers, baggage, cargo and so forth.

When we select the shape and size of the fuselage cross-section, we need to consider aerodynamic and actual requirements, including the strength and layout requirements. A circular or near-circular cross-section is better for a pressure cabin as

a result of strength.

The geometrical parameters which we need to concern are:

- fuselage diameter  $D_f$ ;
- fuselage length  $l_f$ ;
- fuselage aspect ratio  $\lambda_f$ ;
- fuselage nose part aspect ratio  $\lambda_{fnp}$ ;
- fuselage rear part aspect ratio  $\lambda_{frp}$ .

When determining the fuselage length, we need to fully consider the type of the aircraft, features of the scheme, configuration, center of gravity position, etc.

The fuselage length is calculated by the formula:

$$l_f = \lambda_f \cdot D_f = 11.26 \times 3.95 = 44.477 \text{ (m)}.$$

For subsonic aircraft nose parts aspect ratio  $\lambda_{fnp} = 2.1$ .

We can get the length of the fuselage nose part:

$$l_{fnp} = \lambda_{fnp} \cdot D_f = 2.1 \times 3.95 = 8.295 \text{ (m)}.$$

Taking into account the prototype, rear parts aspect ratio is 2.64.

Length of the rear part the fuselage is equal to:

$$l_{frp} = \lambda_{frp} \cdot D_f = 2.64 \times 3.95 = 10.428 \text{ (m)}.$$

For passenger and cargo airplanes fuselage mid-section primarily depends on the size of passenger cabin. For long range airplanes, the height of the passenger cabin  $h_1=1.9$  m; the passage width  $b_p=0.6$  m; the distance from the window to the floor  $h_2=1$ m; the luggage space height  $h_3=0.9\sim 1.3$  m.

The window is made in the shape of rectangular with the rounded corners, it bears the pressure difference and rely on the triple glass structure.

The formula for the cabin width:

$$B_{\text{cabin}} = n_3 \cdot b_3 + n_{\text{aisle}} \cdot b_{\text{aisle}} + 2\delta + 2\delta_{\text{wall}},$$

where  $n_3$  – the number of blocks of seats with 3 seats in a cross-section;  $b_3$  - the width of block of 3 seats, mm;  $n_{\text{aisle}}$  – the number of aisles;  $b_{\text{aisle}}$  – the aisle width,

mm;  $\delta$  - distance between external armrests to the decorative panels, mm; (minimum 50 mm for the first class, minimum 30 mm for others classes);  $\delta_{wall} = 80\sim 120$  - width of the wall (fuselage structure, insulation, decorative panels), mm.

For narrow-body planes as a rule have the number of seats in one row less than or equal to 6.

The cabin height is equal to:

$$H_{cabin} = 1.48 + 0.17 \cdot B_{aisle}$$

The length of passenger cabin is equal to:

$$L_{cabin} = L_1 + (n - 1) \cdot L_{seatpitch} + L_2$$

And the arrangement seats for the aircraft is '2+3' for business class and '3+3' for economy class.

Here are the basic parameters of two class cabin in table 1.3.

Table 1.3 – The parameters of Business class and Economy class cabins

Name, size	Passenger class type	
	Business class	Economy class
Arm-rest width [mm]	55	45
Height of the seat cushion above the floor [mm]	600	
Height of armrests above floor [mm]	320	
Height of the seat top to floor [mm]	1100	
Seat pitch, t [mm]	850	770
Angle of the chair back deflection [°]	36	25



Name, size	Passenger class type	
Seat width [mm]	600	500
Distance from window to floor [mm]	1000	
Width of the block from three chairs, $b_3$ [mm]	1740	1430

Continuation of table 1.3

Width of the block from two chairs, $b_2$ [mm]	1160	-
Block mass of 3 chair [kg]	23	19
Mass of 1 chair [kg]	9	7
Aisle height [m]	1.9	
$b_{aisle}$ [mm]	500	

For business class:

$$B_{cabinbusi} = n_3 \cdot b_3 + n_{aisle} \cdot b_{aisle} + 2\delta + 2\delta_{wall} = 1 \times 1520 + 1 \times 1160 + 1 \times 500 + 2 \times 40 + 2 \times 100 = 3460(\text{mm});$$

$$H_{cabin} = 1.48 + 0.17 \cdot B_{aisle} = 1.48 + 0.17 \times 3.46 = 2.0682(\text{m});$$

$$L_{cabinbusi} = L_1 + (n - 1) \cdot L_{seatpitch} + L_2 = 1200 + (8 - 1) \times 840 + 300 = 7.38(\text{m}).$$

For economical class:

$$B_{cabineco} = n_3 \cdot b_3 + n_{aisle} \cdot b_{aisle} + 2\delta + 2\delta_{wall} = 2 \times 1430 + 1 \times 500 + 2 \times 40 + 2 \times 100 = 3640(\text{mm});$$

$$H_{cabin} = 1.48 + 0.17 \cdot B_{aisle} = 1.48 + 0.17 \times 3.64 = 2.0988(\text{m});$$

$$L_{cabineco} = L_1 + (n - 1) \cdot L_{seatpitch} + L_2 = 1200 + (30 - 1) \times 750 + 300 = 23.25(\text{m}).$$

### 1.3.3. Luggage compartment

Here we can calculate the area of cargo compartment by the formula:

$$S_{cargo} = \frac{M_{bag}}{0.4K} + \frac{M_{cargo\&mail}}{0.6K} = \frac{20 \times 220}{0.4 \times 600} + \frac{15 \times 220}{0.6 \times 600} = 26.67(\text{m}^2).$$

Where K - the unit of load on floor (400~600 kg/m<sup>2</sup>).

The cargo compartment volume is equal to:

$$V_{cargo} = v \cdot n_{pass} = 0.2 \times 220 = 44 (\text{m}^2).$$

### 1.3.4. Galleys

The volume of galley is equal to:

$$V_{\text{galley}} = 0.1 \times 220 = 22(\text{m}^2).$$

The area of galley is equal to:

$$S_{\text{galley}} = \frac{V_{\text{galley}}}{H_{\text{cab}}} = \frac{22}{2.0988} = 10.48(\text{m}^2).$$

Normally the area of each galley is  $1.5\text{m} \times 2.5\text{m}$  and it mainly depends on the airplane size and passenger number.

$$\text{So the number of galley is } n_{\text{galley}} = \frac{10.48}{3.75} \approx 3.$$

### 1.3.5. Lavatories

Number of toilets is determined by the number of passengers and flight duration: when  $t > 4\text{h}$ , one toilet used for 40 passenger. So the number of lavatories is:

$$n_{\text{lav}} = 5$$

Area of each lavatory:

$$S_{\text{lav}} = 1\text{m}^2 \text{ or } 1.5\text{m}^2.$$

### 1.3.6. Calculation of basic parameters of tail unit

The choosing and design of tail unit is one of the most significant tasks for the airplane design. The major difference between wing design and tail design originates from the primary function of tail that is different from wing which the primary function of the wing is to generate maximum amount of lift, while tail is supposed to use a fraction of its ability to generate lift and to ensure stability and controllability, providing pitch and yaw moments [10].

Its center of gravity should be placed in front of the aircraft focal point to ensure the longitudinal stability of the aircraft.

Here I start to calculate the tail unit geometric parameters.

Horizontal tail unit arm:

$$\text{For Trapezoidal scheme, } L_{\text{HTU}} = (0.2 \sim 3.5) \cdot B_{\text{mac}};$$

$$\text{For Light airplane, } L_{\text{HTU}} = (2.0 \sim 2.3) \cdot B_{\text{mac}};$$

$$\text{For Heavy airplane, } L_{\text{HTU}} = (3.2 \sim 3.3) \cdot B_{\text{mac}}.$$

I take  $L_{HTU} = 3 \cdot B_{mac} = 3 \times 5.11 = 15.33(m)$ .

And  $L_{HTU} \approx L_{VTU} = 15.33m$ .

The length of the nose and tail part of the fuselage and wing location can influence the values  $L_{HTU}$  and  $L_{VTU}$ .

Coefficients of static moments:

$A_{htu} = 0.65 \sim 0.8$ ;  $A_{vtu} = 0.08 \sim 0.12$ .

Area of vertical tail unit is equal:

$$S_{VTU} = \frac{l_w \cdot S_w}{L_{VTU}} \cdot A_{VTU} = \frac{42.82 \times 195.054}{15.33} \times 0.1 = 54.483(m^2).$$

Area horizontal tail unit is equal:

$$S_{HTU} = \frac{b_{mac} \cdot S_w}{L_{HTU}} \cdot A_{HTU} = \frac{5.11 \times 195.054}{15.33} \times 0.73 = 50.53(m^2).$$

The following are the determinations of the elevator area and rudder area:

Elevator area:

$$S_{el} = (0.3 \sim 0.4) \cdot S_{HTU} = 0.5 \times 50.53 = 17.686(m^2);$$

Rudder area:

$$S_{rud} = (0.35 \sim 0.45) \cdot S_{VTU} = 0.4 \times 54.483 = 21.793(m^2).$$

The area of aerodynamic balance on elevator and rudder surface:

For the speed of flight  $M > 0.75$ ,

$$S_{aero} = (0.18 \sim 0.22) \cdot S_{control\ surface}$$

Elevator balance area is equal to:

$$S_{eb} = 0.21 \times 17.686 = 3.714(m^2).$$

Rudder balance area is equal to:

$$S_{rb} = 0.22 \times 21.793 = 4.795(m^2).$$

Area of elevator trim tab is equal to:

$$S_{ctr} = (0.08 \sim 0.12) \cdot S_{el} = 0.1 \times 17.69 = 1.769(m^2).$$

Area of rudder trim tab is equal to:

$$S_{rtr} = (0.04 \sim 0.06) \cdot S_{rud} = 0.05 \times 21.793 = 1.09(m^2).$$

Span of HTU and VTU for low wing aircraft:

$$L_{HTU} = (0.32 \sim 0.5) \cdot l_w = 0.4 \times 42.82 = 17.128(m^2);$$

$$H_{VTU} = (0.14 \sim 0.2) \cdot l_w = 0.2 \times 42.82 = 8.564 \text{ (m}^2\text{)}.$$

Tapper ratio of horizontal and vertical tail unit:

For airplanes  $M < 1$ ,  $\eta_{HTU} = 2 \sim 3$ ;  $\eta_{VTU} = 1 \sim 3.7$ ;

Here I take  $\eta_{HTU} = 2.67$ ,  $\eta_{VTU} = 3.67$ .

Tip chord of horizontal stabilizer is:

$$b_{tHTU} = \frac{2 \cdot S_{HTU}}{(\eta_{htu} + 1) \cdot l_{htu}} = \frac{2 \times 0.53}{(2.67 + 1) \times 17.128} = 1.61 \text{ (m)}.$$

Root chord of horizontal stabilizer is:

$$b_{rHTU} = b_{tHTU} \cdot \eta_{VTU} = 1.61 \times 2.67 = 4.3 \text{ (m)}.$$

Tip chord of vertical stabilizer is:

$$b_{tVTU} = \frac{2 \cdot S_{VTU}}{(\eta_{VTU} + 1) \cdot h_{vtu}} = \frac{2 \times 54.483}{(2 + 1) \times 8.564} = 2.73 \text{ (m)};$$

Root chord of vertical stabilizer is:

$$b_{rVTU} = b_{tVTU} \cdot \eta_{VTU} = 2.73 \times 3.67 = 10 \text{ (m)};$$

Relative thickness of stabilizer:

$$c_{HTU} = 0.8 \cdot c_{wing} = 0.8 \times 0.12 = 0.096;$$

$$c_{VTU} = 0.8 \cdot c_{wing} = 0.8 \times 0.12 = 0.096.$$

Horizontal tail unit mean aerodynamic chord:

$$b_{MACHTU} = 0.66 \cdot \frac{\eta_{HTU}^2 + \eta_{HTU} + 1}{\eta_{HTU} + 1} \cdot b_{tHTU} = 3.13 \text{ (m)};$$

Vertical tail unit mean aerodynamic chord:

$$b_{MACVTU} = 0.66 \cdot \frac{\eta_{VTU}^2 + \eta_{VTU} + 1}{\eta_{VTU} + 1} \cdot b_{tVTU} = 7 \text{ (m)}.$$

Tail unit sweptback normally is taken in the range  $3^\circ \sim 50^\circ$  and referring to the prototype, this airplane's parameters are

Horizontal Tail Sweep Angle  $29^\circ$ ;

Vertical Tail Sweep Angle  $34^\circ$ .

### 1.3.7. Landing gear design

The landing gear is the critical component, which supports aircraft on the ground absorbs the kinetic energy of shocks on the structure during the landing

operation. Landing gear plays a decisive role in taxiing, takeoff, and landing for the airplane normal operation.

Main wheel axel offset is:

$$B_M = 0.25 \cdot b_{MAC} = 0.25 \times 5.11 = 1.3 \text{ (m)}.$$

Calculate the landing gear wheel base by the formula:

$$B = (0.3 \sim 0.4) \cdot l_f = 0.4 \times 44.477 = 17.8 \text{ (m)}.$$

Generally, the nose landing gear only supports 5~10% weight of aircraft.

Here we can know the front wheel axial offset is equal to:

$$B_n = B - B_M = 17.8 - 1.3 = 16.5 \text{ (m)}.$$

Wheel track is:

$$T = 0.6 \cdot B_g = 0.6 \times 17.8 = 10.68 \text{ (m)}.$$

The landing gear height should satisfy the overturn angle and tip-back requirement, loading and unloading requirements. The aircraft wheel is usually lightweight and durable, which is chosen by the size and loading on it. The runway surface determines the type of pneumatic device and the pressure in it. The tire is almost entirely dependent on its internal pressure to carry the load.

Nose wheel load is equal to:

$$P_{nose} = \frac{9.81 \cdot B_M \cdot m_0 \cdot K_g}{B_g \cdot z_{nose}} = \frac{9.81 \times 1.3 \times 1.75 \times 116422}{17.8 \times 2} = 72985 \text{ (N)};$$

Where  $K_g = 1.5 \sim 2.0$  - the dynamics coefficient.

Main wheel load is equal to:

$$P_{main} = \frac{9.81 \cdot B_M \cdot m_0}{B \cdot z_{main} \cdot n_{main}} = \frac{9.81 \times 16.5 \times 116422}{17.8 \times 2.4} = 132336 \text{ (N)}.$$

Where  $n$  - the number of supports;

$z$  - the number of wheels on each support.

Table 1.4 - Aviation tires for designing aircraft

Main gear		Nose gear	
Tire size	Ply rating	Tire size	Ply rating

49×18.0-22 mm	30	30×8.8R15 mm	16
---------------	----	--------------	----

### 1.3.8. Power plant

According to the calculation, take-off thrust required of the engine is 173.99 KN, here I use CFM International LEAP 1A as the engine. CFM International LEAP 1A is a twin spool, high bypass turbofan engine, installed on passenger aircraft, such as A320 family, B737max.

Table 1.5 - Parameters of CFM International LEAP 1A

Model	Thrust (KN)	Bypass ratio	Pressure ratio	Wet weight (kg)
CFM International LEAP 1A	143.05	11	40	990

## 1.4. Calculation of the CG of the aircraft

The layout and its center of gravity is the most important process in aircraft design. During the operation of the aircraft, the position of the center of gravity will change as fuel mass is reduced, as well as by loading on the aircraft and it must be as close as possible to ensure the minimum required margin of static stability of the aircraft and controllability [11].

During aircraft design, there is always contradictions between its performances and weight, so all we can do is resolved by making compromise decisions.

### 1.4.1. Calculation of centering of the equipped wing

Mass of the equipped wing contains the mass of its structure, mass of the equipment placed in the wing and mass of the fuel. We also include the weight of the main and the nose landing gear in the mass of the equipped wing.

Supposing CG coordinates does not change in axis Y, here we just consider the axis X of the fuselage. X coordinate of the center of power for the equipped wing are defined by the formula:

$$X'_w = \frac{\sum m_i x'_i}{\sum m_i}$$

where  $X_w$  - the equipped wing center of gravity coordinate;

$\sum m_i$  - the sum of total mass of equipped wing.

The list of the objects and calculations of masses and moments for the equipped wing are shown in the table below (Table 1.6).

Table 1.6 - Trim sheet of equipped wing masses

№	Object name	Mass $m_i$		CG coordinates $X_i, m$	Moment of mass $m_i \cdot X_i$ , $kg \cdot m$
		Units	Total mass (kg)		
1.	Wing (structure)	0.091	10594.4	2.15	22737.7
2.	Fuel system	0.0103	1199.2	2.15	2573.6
3.	Flight control, 30%	0.0051	178.1	3.1	546.1
4.	Electrical equipment	0.0307	357.4	0.51	182.6
5.	Anti-ice system	0.0201	1170	0.51	597.9
6.	Hydraulic systems,	0.0146	1189.8	3.1	6348
7.	Engines	0.08165	9505.9	-1.2	-11407
	Equipped wing without landing gear and fuel		24194.8		18878.9
8.	Nose landing gear	0.03995	417.5	-15.756	-6578.1
9.	Main landing gear	0.03995	4233.6	2.04	8653.4
10.	Fuel	0.34294	39925.8	2.04	81608.3
	Total	0.59071	68771.6		102562.9

In the end, we can get  $X_w = \sum m_i \cdot X_i / \sum m_i = 1.491$  m.



#### 1.4.2. Calculation of centering of the equipped fuselage

In the same way, the list of the objects for the aircraft is shown in Table 1.7.

Here we calculate the CG coordinates of the fully equipped fuselage by the formula:

$$X_f = \frac{\sum m'_i X_i}{\sum m'_i}$$

where  $X_i$  - fuselage center of gravity coordinate;

$\sum m_i$  - sum of total mass of fuselage.

Table 1.7 - Trim sheet of equipped fuselage masses

№	Objects names	Mass $m_i$		Center of gravity coordinates $X_i$ , m	Moment of mass $m_i \cdot X_i$ , kg•m
		Units	Total mass, kg		
1.	Fuselage	0.09802	11411.7	22.2	253778
2.	Horizontal tail	0.00941	1095.5	40.63	44511.4
3.	Vertical tail	0.00934	1087.4	36.7	39906.9
4.	Navigation equipment	0.0043	500.6	1.5	750.9
5.	Radio equipment	0.0022	256.1	1.5	384.2
6.	Radar	0.00029	33.8	0.5	16.88
7.	Instrument panel	0.005	582.11	1.8	1047.8
8.	Flight control,70%	0.0051	415.6	22.2	9242.9
9.	Hydraulic system,30%	0.0146	509.9	26.7	13608.1
10.	Anti-ice system,25%	0.0201	585.02	13.3	7805.99
	Airconditioning system,25%	0.0201	585.02	22.2	13009.98
11.	Electrical equipment, 90%	0.0307	3216.7	22.2	71535.5
12.	Lining and insulation	0.0058	675.25	22.2	15016.5

Continuation of table 1.7

13.	Not typical equipment	0.002	232.8	22.2	5178.1
14.	Lavatory 1	0.0012	143.43	3.97	569.4
	Lavatory 2	0.0012	143.43	24.88	3568.6
	Lavatory 3	0.0012	143.43	24.88	3568.6
	Lavatory 4	0.0012	143.43	38	5450.5
	Lavatory 5	0.0012	143.43	38	5450.5
	Galley 1	0.0018	214.95	3.97	853.3
	Galley 2	0.0018	214.95	39.44	8477.44
	Galley 3	0.0018	214.95	39.44	8477.44
15.	Operation item	0.01857	214.95	22.2	48078.67
16.	Passenger seats	0.0071	839.36	22.2	18465.9
	Equipped fuselage without payload		25542		578754.2
17.	Passenger	0.13054	15197.7	22.2	337974.7
18.	Baggage	0.01106	1287.6	22.2	2863409
19.	Cargo	0.0346	4028.2	22.2	8958102
20.	Crew	0.00461	536.7	2	1073.4
21.	Onboard meal	0.009048	1053.4	20	21067.7
	TOTAL	0.40924914	47645.6		1057086.1

We can get fuselage center of gravity coordinate  $X_f$ :

$$X_f = \sum m_i \cdot X_i / \sum m_i = 22.19 \text{ m.}$$

Due to different coordinates, here change them to one same coordinate by the formula:

$$m_f \cdot x_f + m_f \cdot (x_{MAC} + x'_w) = m_0 \cdot (x_{MAC} + C),$$

where  $m_0$  – the aircraft takeoff mass, kg;  $m_f$  – the mass of fully equipped fuselage, kg;  $m'_w$  – the mass of fully equipped wing, kg;  $C$  – the distance from MAC leading edge to the center of gravity point.

$$C = (0.23 \sim 0.25) B_{MAC} \text{ – for low wing.}$$

Here we can get  $X_{MAC} = 21.22 \text{ m.}$

The list of mass objects for CG variants calculation is in Table 1.8. And the airplanes CG position variants in different conditions are shown in Table 1.9.

Table 1.8 - Calculation of CG positioning sheet

№	Object name	Mass, $m_i$ , Kg	C.M. coordinate $X_i$ , m	Mass moment $m_i \cdot X_i$ , kg•m
1.	Equipped wing (without fuel and landing gear)	24194.8	22	532180
2.	Nose landing gear (extended)	417.48	5.4	2279.2
3.	Main landing gear (extended)	4233.58	23.26	98470
4.	Fuel	39925.77	23.26	928647.9
5.	Equipped fuselage (without payload and crew)	25541.96	22.66	578754.23
6.	Passengers	15197.7	22.24	337974.67
7.	Baggage	1287.6	22.24	28634.9
8.	Cargo	4028.2	22.24	89581.15
9.	Crew	536.71	2	1073.4
10.	Nose landing gear (retracted)	417.48	4.4	1861.7
11.	Main landing gear (retracted)	4233.58	23.26	98470.4
12.	Reserve fuel	4063.1	23.26	94505.8

Table 1.9 - Airplanes CG position variants

№	Name	Mass, kg	Mass Moment, $m_i \cdot X_i$ , kg•m	Center of mass, $X_{c.m.}$	CG point
1.	Take off mass (LG extended)	115363.86	2598514.77	22.5	0.26
2.	Take off mass (LG retracted)	115363.86	2598097.3	22.52	0.25
3.	Landing weight (LG extended)	79501.22	1764089.87	22.2	0.19
4.	Ferry version (without payload)	94850.3	2141906.57	22.57	0.27

5.	Parking version (without payload, fuel, crew, LG extended)	54387.8	1212287.9	22.28	0.21
----	--	---------	-----------	-------	------

### **Conclusion to the part 1**

On the base of the similar planes analysis and required calculations the preliminary design of the new long-range passenger aircraft has been created.

The following tasks have been solved along the work on preliminary design:

- Wing and tail unit geometry calculation;
- fuselage layout;
- basic parameters of lavatory and galley;
- landing gears basic parameters and location and Type of engines;
- calculation of the aircraft center of gravity position.

Analyzing the results, we can know the CG positions in different conditions are in normal range (0.18~0.3) and conclude that the designed prototype meets the requirements of the stability and controlability.

The aircraft is narrow-body and has single-aisle layout. The airplane fitted with sharklets and new engine, CFM International's LEAP-1A. Advanced and proven technologies applied on the aircraft is the main trend to provide economical and environmental protection in the recent years.

The plane presented in the diploma paper meets primary requirements of the international and China's airworthiness.

## **PART 2**

### **BALL MAT DESIGN**

#### **2.1 Introduction**

Nowadays, air freight and people's lives are closely related. For example, if there are some urgent expresses need to be delivered to the users as soon as possible, it is necessary to use air transport. When a sudden outbreak of the epidemic occurs, just like the coronavirus last year, we mainly rely on air transport to deliver medical supplies. Air cargo in the economic development of countries and international trade has a considerable proportion of the country's economic development.

A ball mat is an integral part of loading system used in airplane, which is the device to support and assist the movement of cargo on the loading deck. The ball mat consists of a cover plate, a floor plate which extends parallel to the cover plate, and a number of holders that balls can be inserted, and there is defined an interior within which the holders are disposed between cover plate and floor plate. Each ball is located in a groove supported by a number of smaller balls to transmit the load applied to the plane from all directions and the remaining space in the interior is filled with foam to increase the stability of the ball mat and to prevent moisture from entering and spreading therein [12].

Ball Mat decks are manufactured in modular sections for transportation, handling and relocation conveniently, which allows for the horizontal movement of cargo in all directions [13]. And ball mat usually has non-slip working surface. The ball units are holed in position (figure 2.2).

Its main goal is to reduce manpower and loading/unloading time to improve the turnaround efficiency.

The ball mat is mounted parallel to the aircraft floor, as shown in figure 2.1.

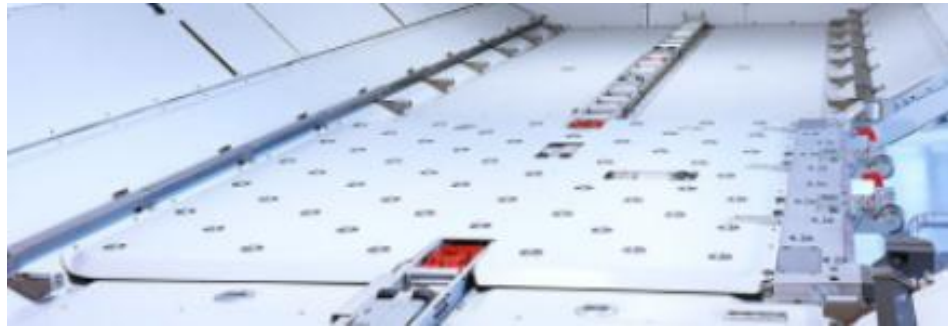

Figure 2.1 - Ball mat [14]

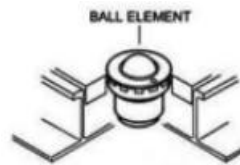

Figure 2.2 - The mounting condition of the Ball unit

## 2.2 The dimensions of the Cargo hold or Containers compartment

According to the prototype and part 1, we can know the basic parameters about the cargo compartment. Each cargo compartment is in the lower deck capacity which has several loading positions. The figure 2.3 shows the general longitudinal dimension of cargo compartment.

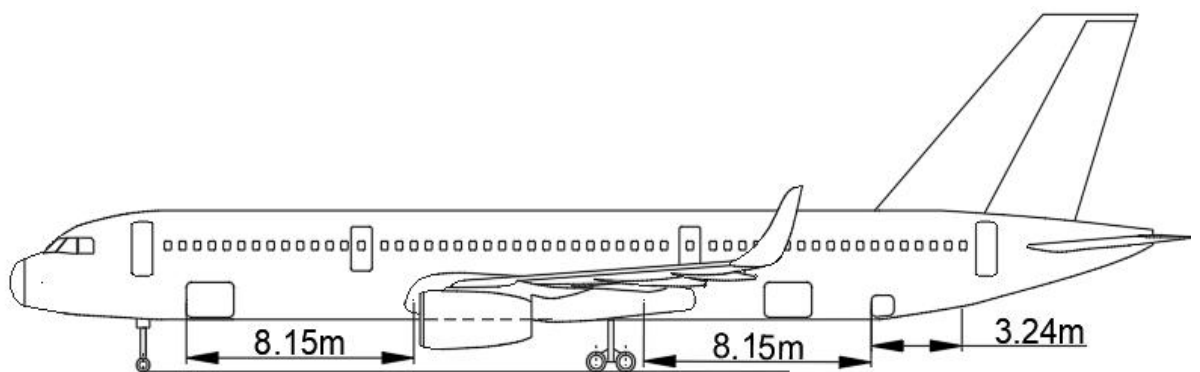

Figure 2.3 - The general longitudinal dimension of cargo compartments

The conveying device is mainly used to transfer the goods to the target location, including the two ways of assembly transfer and bulk transfer. Among them, the

assembly transfer includes rollers, PDU, universal rotation wheel, ball mat, power-driven push plate device, rolling damping device, latches, etc. The cargo compartments from 1 to 4 can be used for bulk or ULD loading but cargo compartment 5 is only for bulk cargo [15]. The figure 2.4 shows the layout of cargo compartment of the airplane.

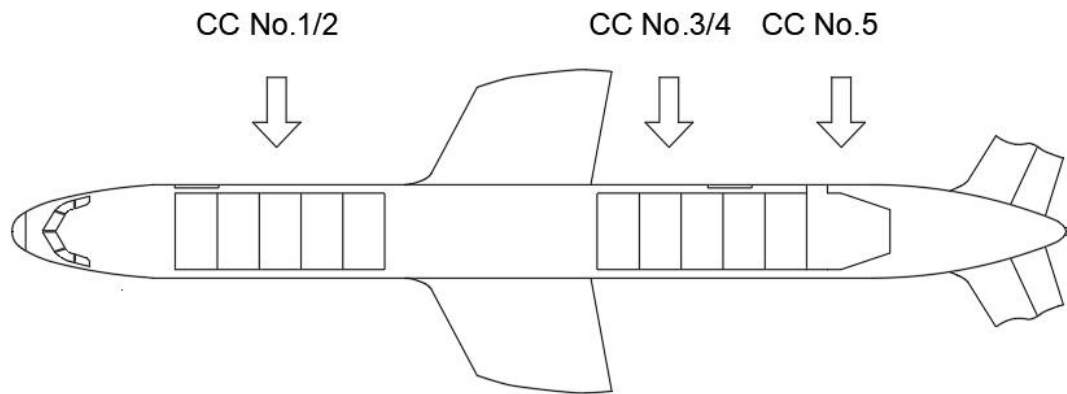

Figure 2.4 - The layout of cargo compartments

Here is a table about the difference of the forward, aftward and bulk compartment loading, as shown in table 2.1.

Table 2.1 - The parameters of cargo compartment loading

	Number of ULD	Max load weight (kg)	Maximum load capacity per unit area (kg/m <sup>2</sup> )
FWD	5	5670	488
AFT	5	5670	488
BULK	0	1497	732

The figure 2.5 shows the cross section of fuselage and main dimensions of cargo compartment.

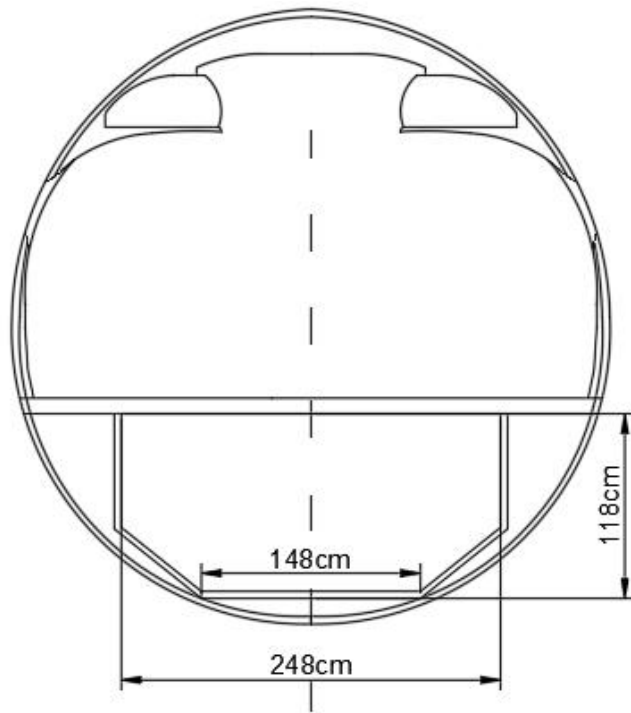

Figure 2.5 - The cross section of fuselage

Typically, each row in a cargo compartment consists of two positions. Each half-width container in the aircraft occupies one position. And a full-width container will take two positions. A ULD that adapts the configuration of the hold maximises space in the cargo compartment, which called optimal fit, as seen in figure 2.6. Sometimes ULD can be used in other type of airplane but just doesn't be make the most of every hold's space. Actually, ULD can be compatible with several different airplane.

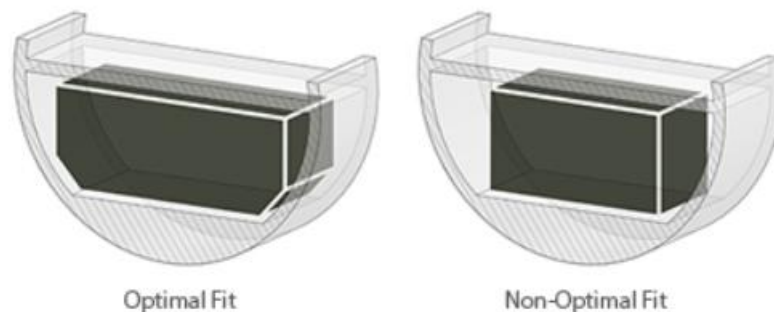

Figure 2.6 - Optimal fit and Non-optimal fit



Table 2.2 - The common ULDs and their specifications

ULDs type	Volume	Linear dimensions (Base width / overall width × depth × height)	Suitable for
Container			
LD1	4.9 m <sup>3</sup>	156 / 234 × 153 × 163 cm	B747, B767, B777
LD2	3.4 m <sup>3</sup>	119 / 156 × 153 × 163 cm	B767
LD3	4.5 m <sup>3</sup>	156 / 201 × 153 × 163 cm	A310, A330, A340, B747, B767, B777
LD6	8.95 m <sup>3</sup>	318 / 407 × 153 × 163 cm	A310, A330, A340, B747, B777
LD8	6.88m <sup>3</sup>	244 / 318 × 153 × 163 cm	B767
LD11	7.16m <sup>3</sup>	318 × 153 × 163 cm	A310, A330, A340, B747, B777
Pallet			
LD8	6.88m <sup>3</sup>	153 × 244 cm	B767
LD11	7.16m <sup>3</sup>	153 × 163 cm	A310, A330, A340, B747, B777

Here are the calculations of the area load:

The area of cargo compartment = (8.15m+8.15m) × 1.48m=24.124 m<sup>2</sup>.

The Maximum load capacity per unit area for forward and aft cargo compartment is 488 kg/m<sup>2</sup>.

The area load is:

$$n = \frac{W}{S} = \frac{5670 + 5670}{24.124} = 470.1 \text{ kg/m}^2$$

And we can know the area load = 470.1 kg/m<sup>2</sup> < 488 kg/m<sup>2</sup>, satisfy the limitation.

ULDs are regulated by the Federal Aviation Administration (FAA). Due to the limitation of cargo compartment dimensions, here i just consider the suitable container and pallet for the plane.

The full-width container used in the airplane is AKH (LD3-45WF), as shown in figure 2.7.

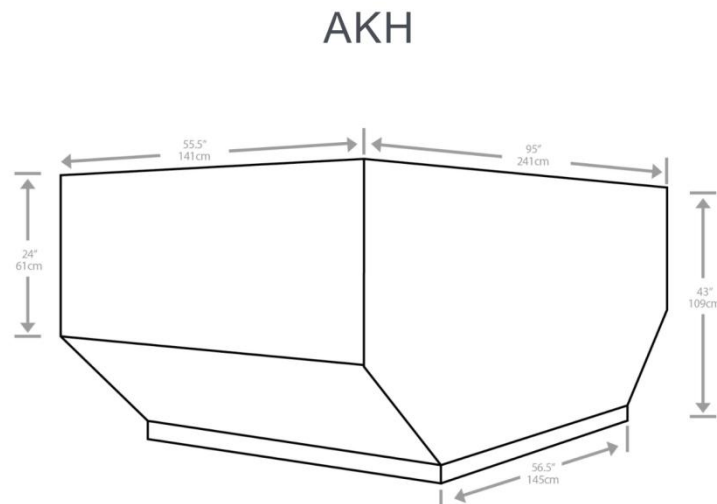

Figure 2.7 - AKH container

And its technical specification is listed in the table 2.3.

Table 2.3 - AKH technical specification

Volume	3.4 m <sup>3</sup>
Tare weight	76 kg
Dimension	141×145×109 cm
Weight Limit include ULD Tare Weight	1134 kg
Net allowed weight	1.505 kg
Max Structural Load	1.587 kg

Another ULD form is pallet. Some cargo only can be loaded on open pallets due to its shape or volume. The pallet used in the airplane is PKC, as shown in figure 2.8.



Figure 2.8 - PKC pallet

And its technical specifications are listed in the table 2.4.

Table 2.4 - PKC technical specification

Volume	2.5 m <sup>3</sup>
Max Gross Weight	1134 kg
Tare weight	40 kg
Dimension	153.4×156.2×114.3 cm
Usable area of base	140.7×143.2 cm
Net allowed weight	1.547 kg
Max Structural Load	1.587 kg
Max Surface Load	907 kg/m <sup>2</sup>

Different types decide the dimensions of ULD. There are even some subtle distinctions of container dimension in same type in different air cargo company. In addition, containers have some other special uses: Reefer container. Nowadays the epidemic is spreading globally and the transportation of vaccine is imperative. UltraFreezers are developed to meet the requirement of the temperatures for the vaccine storage, such as Envirotainer container RKN e1, t2, and so forth, which dramatically relieved the tensivity of the pandemic all around the world.

### 2.3 The dimensions of the Ball Mat module

There is a big difference in cargo compartment between passenger airplane and freighter airplane. First of all, the cargo compartments in passenger airplane usually are located in the lower deck. But the freighter airplanes use the upper deck as cargo compartment instead of the passenger cabin. Besides, the cargo loading system (CLS) in cargo airplane is more complicated.

The distribution and number of balls are determined by the cargo weights and sizes. Normally we can use these two types of layouts: in-line arrangement and staggered arrangement. Since the airplane is passenger airplane and after the preliminary estimation, the ball unit has enough strength to withstand the load. It is better to use staggered arrangement which the weight is lower.

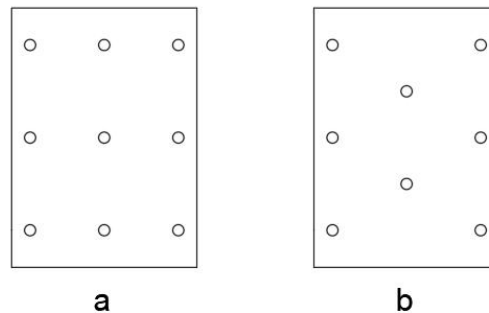

Figure 2.9 - Ball mat layout: a - in-line arrangement; b - staggered arrangement

The max distance between the roller balls " $a_2$ " is obtained by:

$$a_2 = \frac{a_1}{2.5}$$

where  $a_1$  – the shortest edge length of the load.

It ensures that a load will always be supported by carrier balls thus preventing it from tipping over into an empty space [16].

$$a_2 = \frac{153.4}{2.5} = 61.36 \text{ cm.}$$

Because of the low conveying speed, I do not take into account the friction values of the balls, resistance to temperature and lubrication.

Through the previous introduction, we know the dimensions of the cargo compartment. Considering the limitation of container or pallet dimension, I take the length equal to 70 cm and width equal to 160 cm. The layout of the ball mat is showed below in figure 2.10.

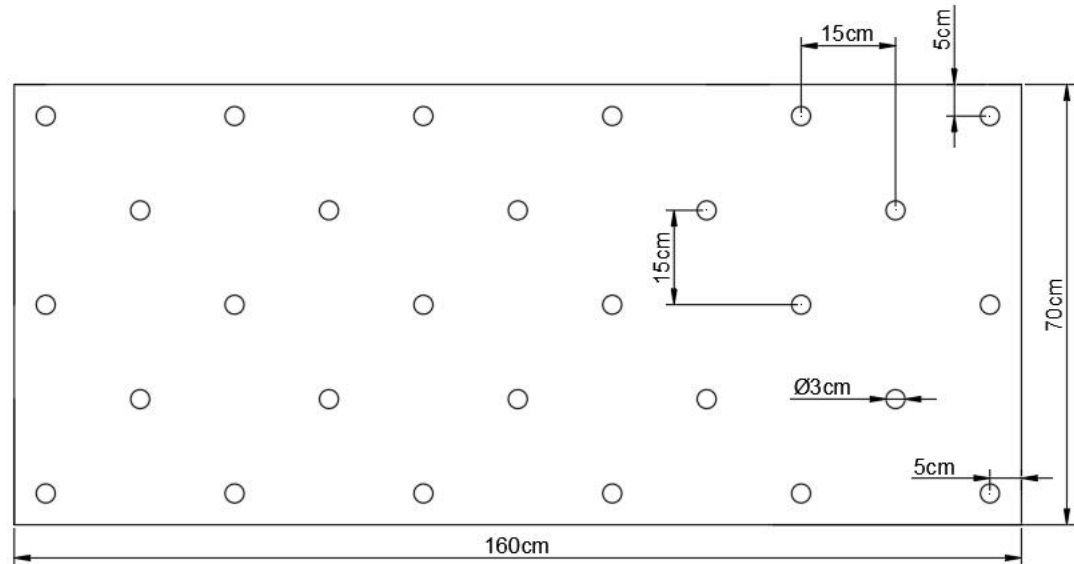

Figure 2.10 - The layout of BM

Here we can get the preliminary calculation of the load on Ball Unit:

The area of the Ball Mat module =  $0.7\text{m} \times 1.6\text{m} = 1.12 \text{ m}^2$ .

The load on the module =  $470.1 \text{ kg/m}^2 \times 1.12 \text{ m}^2 = 526.48 \text{ kg}$ .

The load on each Ball Unit =  $526.48/28 = 18.8 \text{ kg} < 250 \text{ kg}$ .

Additionally, we need to consider the locations of PDU, latches and the cargo door sill latches. Roller tray assembly is installed on the center tray, which the width is 8mm. When loading the ULD, there is a process to totally load in the position which means the weight firstly loads on the ball mat located near the door. Finally, we can get the advanced layout, as shown in figure 2.11.

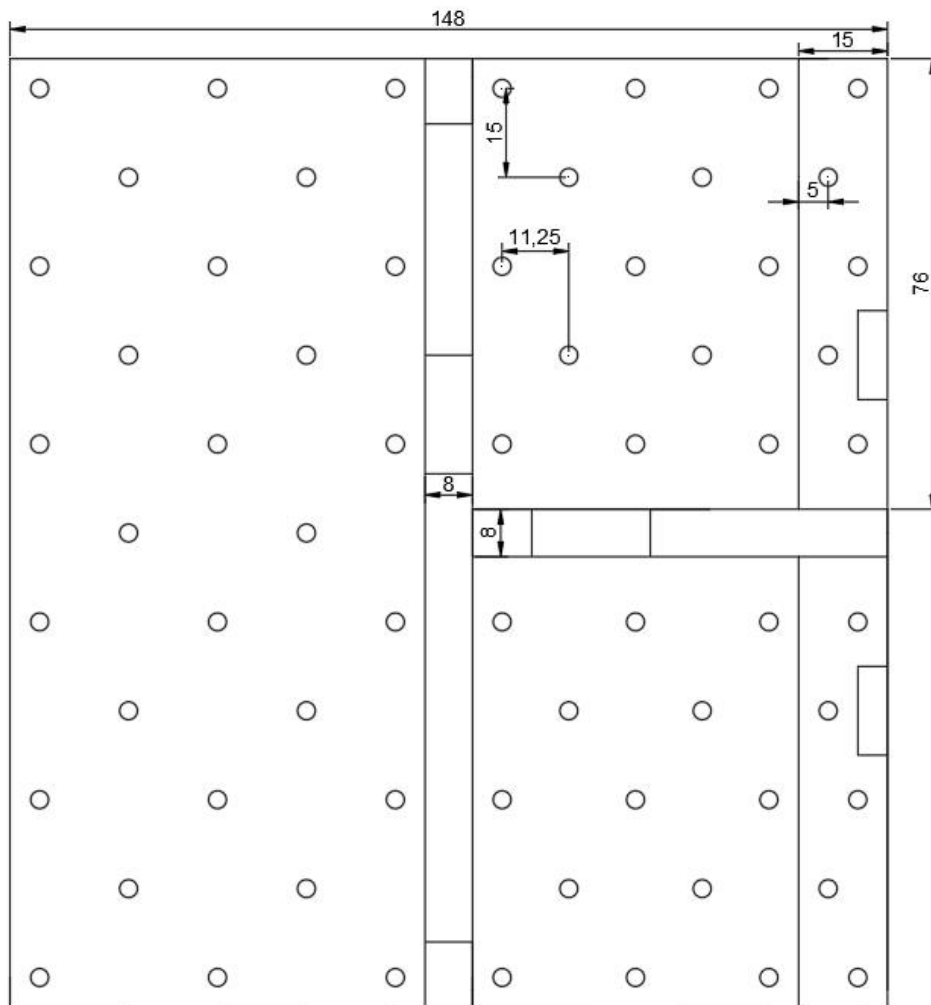

Figure 2.11 – The final layout of ball mat

The calculation of all loads on the ball mat when the PDU lifts down:

The load on each Ball Unit =  $5670/64 = 88.6 \text{ kg} < 250 \text{ kg}$ .

#### 2.4 The material for the Ball Mat module and Ball Unit

When we load the cargo in the cargo compartment, Ball mat module needs high rigidity due to the hard touch; high strength to withstand the load; enough durability and reliability to insure the regular operation. Traditional aluminium have a number of drawbacks: suffering from durability issues, high maintenance cost and low resistance. Although composite materials have small specific gravity, high specific strength and multiple advantages such as wearing resistance, corrosion

resistance and fatigue resistance, but impact resistance and fracture toughness are significantly lower than the general metal, especially in the resistance to the impact of metal-based material items on the performance is particularly poor. Besides, the cost of composite material is higher. Here i choose stainless steel as the material of Ball mat.

There are so many different series of ball mat and various companies produced it, such as ALWAYSSE, Ganter, etc. Here I just list the advantages of two series of ballmats in ALWAYSSE in table 2.5.

Table 2.5 - Advantages of different type of ball mat

Type	Advantages
805 Series	the original heavy duty air cargo unit; the industry standard and suitable for most conditions.
888 Series	Reduced friction for easier movement of ULDs; Improved corrosion resistance; The new series also features a modified dirt exit hole with a 30% increase in the opening area.

Here is the sketch drawing of the Ball unit in figure 2.12

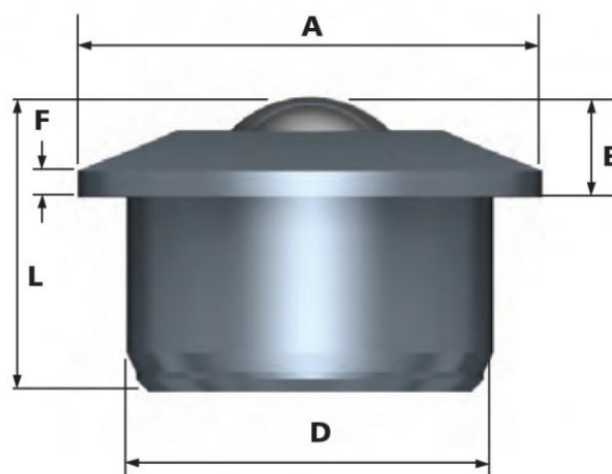

Figure 2.12 - The drawing of the Ball unit

Table 2.6 shows the detailed ball mat specifications of Type 805-30-16 and Type 880-30-16.

Table 2.6 - Ball mat specific specification

	Type 805-30-16	Type 880-30-16
Max dynamic loading(kg)	350	350
Load ball up		
Weight(kg)	0.36	0.29
Load ball diameter(mm)	30	30
Dimension A - Max Diameter (mm)	55	50
Dimension B - Working Height of Ball (mm)	13.8 +/- 0.2	13.8 +/- 0.2
Dimension D - Body Diameter (mm)	45 +/- 0.08	45 +/- 0.08
Dimension F - Flange Thickness (mm)	3.4	2
Dimension L - Overall Height (mm)	36.8	34.8
Fixing Methods	Hole	Hole
Material of Load Ball	Stainless Steel	Stainless Steel
Material of Support Ball	Stainless Steel	Stainless Steel
Tensile yield strength	207 MPa	207 Mpa
Unit Housing Material	Stainless Steel - Bright Zinc Plated	Stainless Steel - Bright Zinc Plated
Load Capacity Ranges	250 kg	250 kg



The unit weight of Type 880-30-16 is lower and it features a completely new design with improved Corrosion resistance and 10% Greater load ball exposure. Its tapered body is also more easier for installation. Finally, it is better to choose the Type 880-30-16 as the ball unit.

## 2.5 Ball Unit modelling and Analysis

To stimulate the condition that the ULD loads on the ball mat, I construct a three-dimensional model of the assembly in SOLIDWORKS and perform a finite element analysis of the structure using ANSYS software.

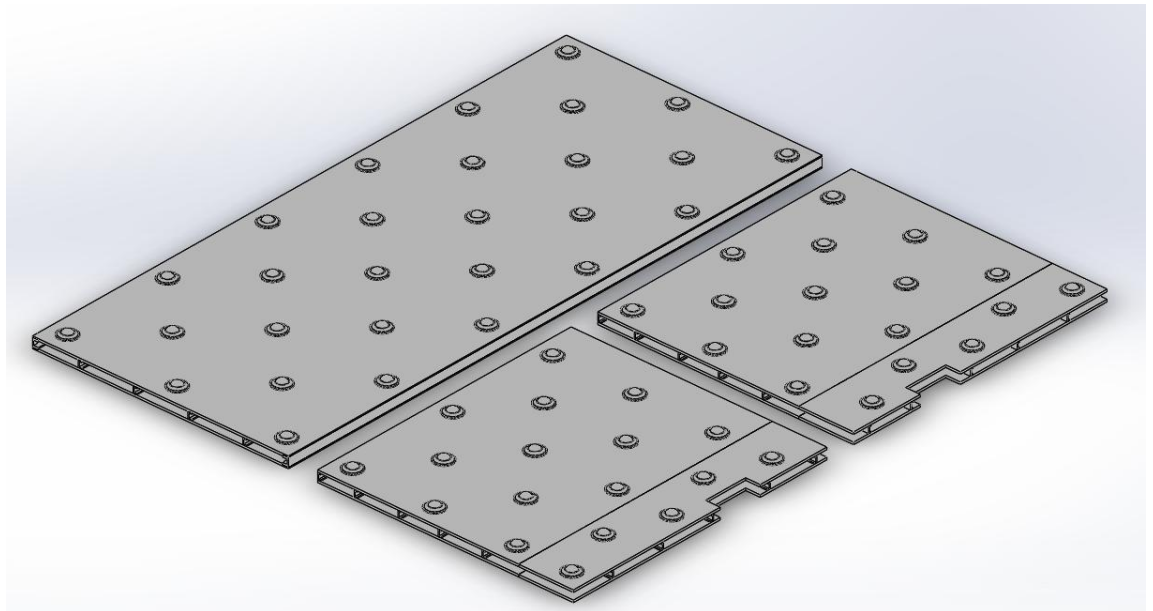

Figure 2.13 - Ball mat created in SOLIDWORKS

When importing the computational model, the geometric and mechanical characteristics are guaranteed to be close to the real situation, and the shape and position of the primary structure are retained as much as possible for the main load-bearing parts and their structures, while the non-main load-bearing parts and their structures are not considered or simplified, such as removing various screw holes and small contact blocks, in order to reduce the number of cells and speed up the computational speed.

After transmitting the model in the ANSYS, firstly select alluminium alloy as the material of the container base plate, up and down plate and stain steel as the material of the ball unit. Then mesh the model, as shown in figure 2.14.

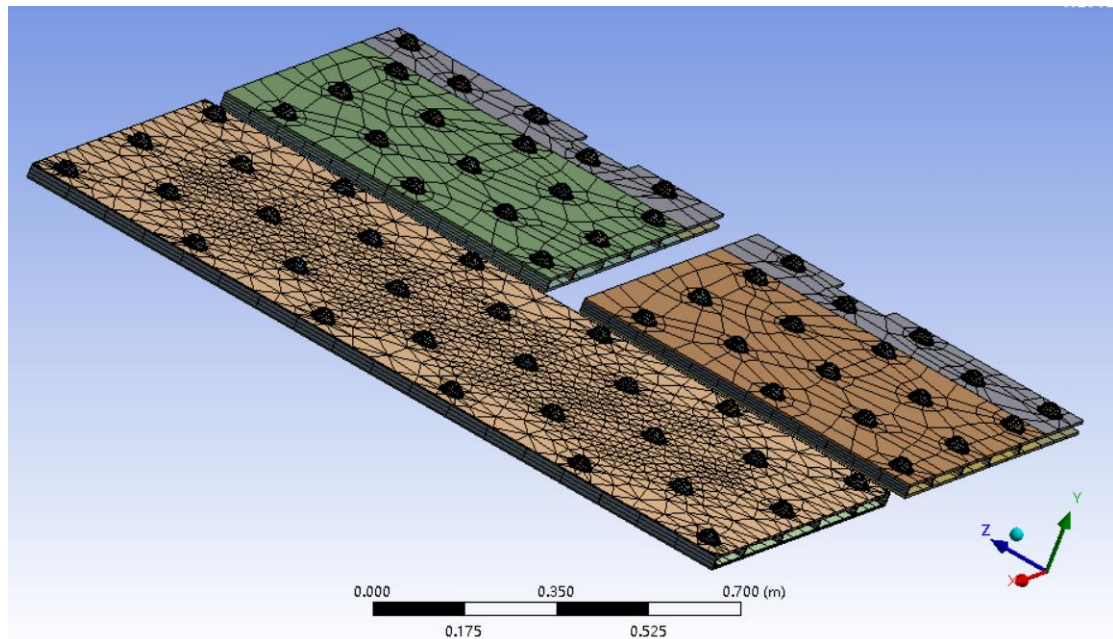

Figure 2.14 - Meshing in static structural application

The ball mat is installed on the airplane floor, so choose the down plate as fixed support. The uniform load on the ball transfer device comes from a 20mm container base plate, which is loaded with a downward load of 55566 N. The loading position is shown in Figure 2.15.

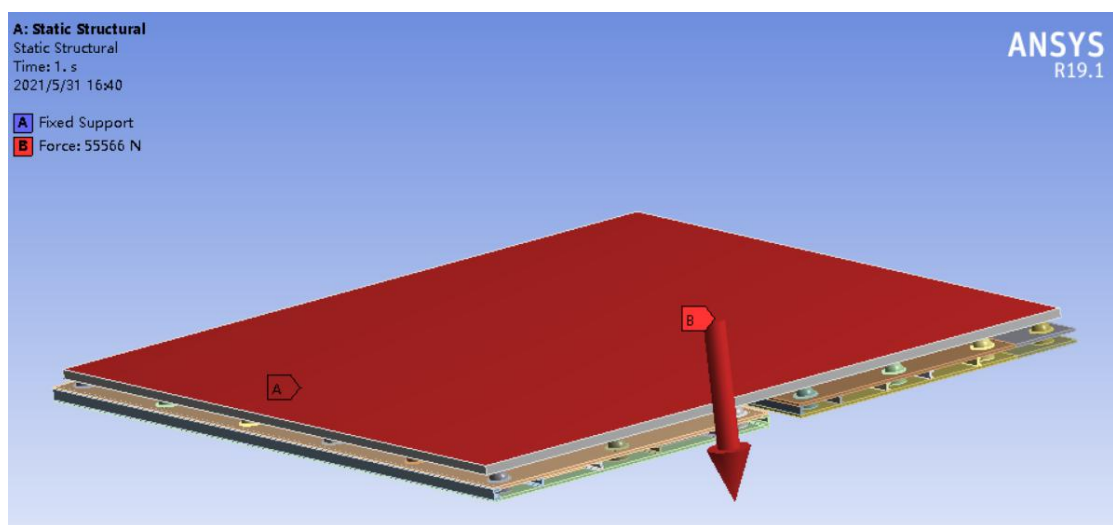

Figure 2.15 - Loading condition

The simulation was carried out by the finite element analysis software, and the equivalent stress and total deformation clouds of the ball mat were obtained as shown in Figure 2.16 and Figure 2.17. Therefore, from Figure 2.16, the maximum deformation of the lower panel is 0.0004 mm, which is less than the allowable deformation of the lower panel of the structure by 0.5mm. And the max stress is 7.355 MPa, meeting the strength requirement.

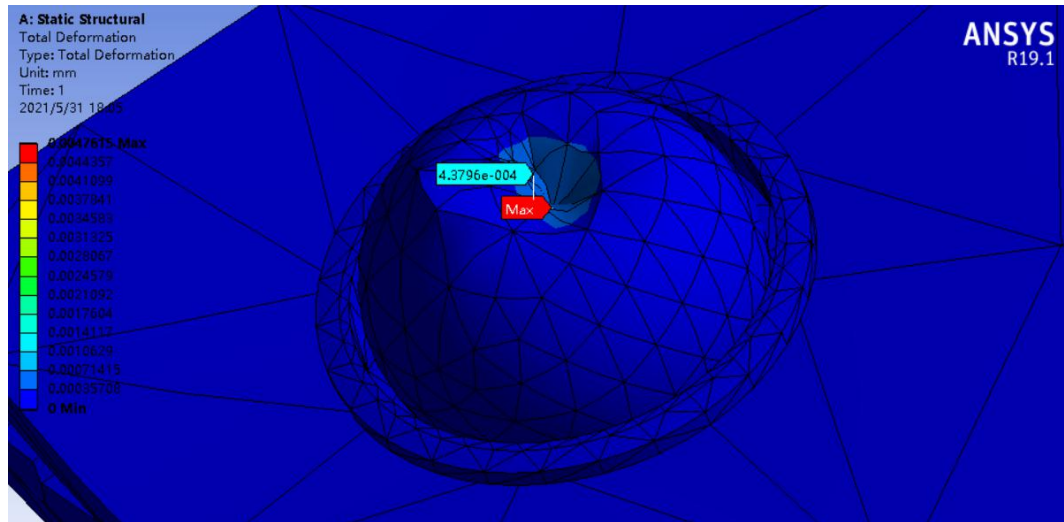

Figure 2.16 - Total deformation

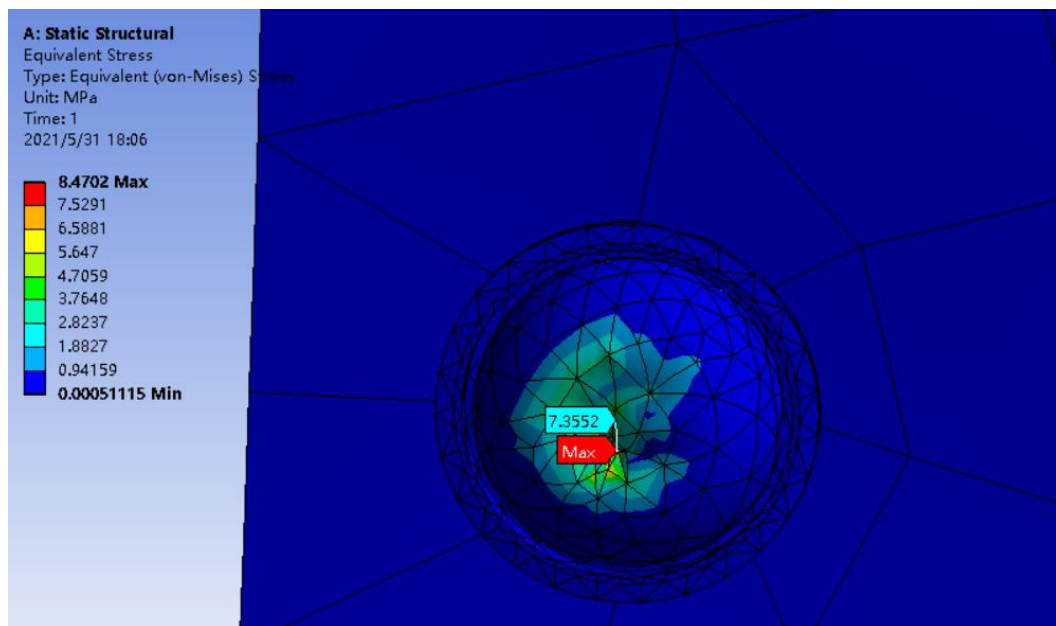

Figure 2.17 - Equivalent stress

## **Conclusion to the part 2**

After calculations and analysis, I've got the preliminary design of ball mat.

The following tasks have been solved along the work on special part:

- The dimensions of the cargo hold or containers compartment;
- the dimensions of the ball mat module;
- the material for the ball mat module and ball unit;
- ball unit modelling and analysis.

Analyzing the results, we can know the strength and deformation are in reasonable range. At last, we conclude that this part meets the requirements of the material and feasibility.

The ball mat device is mounted on the floor of the aircraft cargo hold hatch area and is used for transferring, steering and supporting the container in any direction during loading and unloading; during air transport, it is used for supporting the assembly unit in the hatch area.

## **General Conclusion**

During this designing work, we completed the preliminary design of the plane and ball mat design and got the basic parameters of the aircraft. The centre of gravity position of the aircraft are in correct range which satisfy the airplane stability requirements during in flight and on the ground.

Aircraft design is complicated and we need to take into account as many other factors as possible, such as manufacture, market, cost, rationality.

The aircraft is narrow-body and single-aisle layout which accommodates 220 passengers. The major prototype is Airbus 321-neo, fitted with new engine and other advanced technology. The three-dimensional structure of the ball transfer device was designed by Solidworks software, and the strength of the ball transfer device was performed by using ANSYS software. After the calculation of ball mat, we successfully select the optimal type of ball unit, Type 880-30-16. The application makes cargo loading and unloading much easier.

## Reference

- [1] <https://studfile.net/preview/4372982/page:17>
- [2] <https://www.easa.europa.eu/newsroom-and-events/news/easa-certifies-airbus-a321neo>
- [3] <https://www.airbus.com/aircraft/passenger-aircraft/cabin-comfort.html>
- [4] <https://studfile.net/preview/5375453/page:5>
- [5] <https://www.linkedin.com/pulse/evolution-aircraft-industries-news-technologies-teles-de-paula>
- [6] <https://dergipark.org.tr/tr/download/article-file/629766>
- [7] <https://studfile.net/preview/5375453/page:5/>
- [8] <https://dergipark.org.tr/tr/download/article-file/629766>
- [9] [https://www.fzt.haw-hamburg.de/pers/Scholz/HOOU/AircraftDesign\\_8\\_HighLift.pdf](https://www.fzt.haw-hamburg.de/pers/Scholz/HOOU/AircraftDesign_8_HighLift.pdf)
- [10] [http://www.aero.us.es/adesign/Slides/Extra/Stability/Design\\_Tail/Chapter%206.%20Tail%20Design.pdf](http://www.aero.us.es/adesign/Slides/Extra/Stability/Design_Tail/Chapter%206.%20Tail%20Design.pdf)
- [11] V.D. Kravchenko. Preliminary design of cargo short-range aircraft with cargo capacity 5,5 tons [D], NAU, 2020.
- [12] <https://patents.google.com/patent/US6125984A/en>
- [13] <https://www.bdp-solutions.co.uk/docs/Ball%20mat.pdf>
- [14] [https://www.google.com/url?sa=i&url=https%3A%2F%2Ftelair.com%2Fa320\\_1ower\\_deck\\_air\\_cargo\\_modcar%2F&psig=AOvVaw3HyxoO5oP4dB5UE5TiljtZ&ust=1622470815882000&source=images&cd=vfe&ved=0CA0QjhxqFwoTCKiaroDN8fACFQAAAAAdAAAAABAO](https://www.google.com/url?sa=i&url=https%3A%2F%2Ftelair.com%2Fa320_1ower_deck_air_cargo_modcar%2F&psig=AOvVaw3HyxoO5oP4dB5UE5TiljtZ&ust=1622470815882000&source=images&cd=vfe&ved=0CA0QjhxqFwoTCKiaroDN8fACFQAAAAAdAAAAABAO)
- [15] <https://docplayer.net/60906206-I-introduction-the-cargo-loading-system.html>
- [16] <https://docplayer.net/63876237-Screws-and-nuts-washers-3-2lifting-accessories.html>

## Appendix A

### INITIAL DATA AND SELECTED PARAMETERS

Passenger Number 220

Flight Crew Number 2

Flight Attendant or Load Master Number 6

Mass of Operational Items 2162.06kg

Payload Mass 20020.80kg

Cruising Speed 850km/h

Cruising Mach Number 0.7966

Design Altitude 11.00km

Flight Range with Maximum Payload 7200km

Runway Length for the Base Aerodrome 2.95km

Engine Number 2

Thrust-to-weight Ratio in N/kg 3.1

Pressure Ratio 30

Assumed Bypass Ratio 6

Optimal Bypass Ratio 6

Fuel-to-weight Ratio 0.17

Aspect Ratio 9.40

Taper Ratio 4.11

Mean Thickness Ratio 0.12

Wing Sweepback at Quarter Chord 25°

High-lift Device Coefficient 1.16

Relative Area of Wing Extensions 0.05

Wing Airfoil Type super critical

Winglets yes

Spoilers installed

Fuselage Diameter 3.95m

Finess Ratio 11.26

Horizontal Tail Sweep Angle 29°

Vertical Tail Sweep Angle 34°

### CALCULATION RESULTS

Optimal Lift Coefficient in the Design Cruising Flight Point 0.45135

Induce Drag Coefficient 0.00911

ESTIMATION OF THE COEFFICIENT  $D_m = M_{critical} - M_{cruise}$

Cruising Mach Number 0.7966

Wave Drag Mach Number 0.80698

Calculated Parameter  $D_m$  0.01038

Wing Loading in kPa (for Gross Wing Area):

At Takeoff 5.557  
At Middle of Cruising Flight 4.562  
At the Beginning of Cruising Flight 5.352

Drag Coefficient of the Fuselage and Nacelles 0.00847  
Drag Coefficient of the Wing and Tail Unit 0.00915

Drag Coefficient of the Airplane:

At the Beginning of Cruising Flight 0.0927  
At Middle of Cruising Flight 0.02769

Mean Lift Coefficient for the Ceiling Flight 0.45135

Mean Lift-to-drag Ratio 16.299168

Landing Lift Coefficient 1.623

Landing Lift Coefficient (at Stall Speed) 2.435

Takeoff Lift Coefficient (at Stall Speed) 1.984

Lift-off Lift Coefficient 1.448

Thrust-to-weight Ratio at the Beginning of Cruising Flight 0.553

Start Thrust-to-weight Ratio for Cruising Flight 2.342

Start Thrust-to-weight Ratio for Safe Takeoff 2.847

Design Thrust-to-weight Ratio 2.989

Ratio  $D_r = R_{cruise} / R_{takeoff}$  0.823

SPECIFIC FUEL CONSUMPTIONS (in kg/kN·h):

Takeoff 34.8865  
Cruising Flight 57.8883  
Mean cruising for Given Range 63.2099

FUEL WEIGHT FRACTIONS:

Fuel Reserve 0.03490

Block Fuel 0.30804

WEIGHT FRACTIONS FOR PRINCIPAL ITEMS:

Wing 0.09100  
Horizontal Tail 0.00941  
Vertical Tail 0.00934  
Landing Gear 0.03995  
Power Plant 0.09195  
Fuselage 0.09802  
Equipment and Flight Control 0.11679  
Additional Equipment 0.00986  
Operational Items 0.01857  
Fuel 0.34294  
Payload 0.17223

Airplane Takeoff Weight 116422kg

Takeoff Thrust Required of the Engine 173.99kN

Air Conditioning and Anti-icing Equipment Weight Fraction 0.0201

Passenger Equipment Weight Fraction 0.0129  
(or Cargo Cabin Equipment)

Interior Panels and Thermal/Acoustic Blanketing Weight Fraction 0.0058

Furnishing Equipment Weight Fraction 0.0117

Flight Control Weight Fraction 0.0051



Hydraulic System Weight Fraction 0.0146  
Electrical Equipment Weight Fraction 0.0307  
Radar Weight Fraction 0.00029  
Navigation Equipment Weight Fraction 0.0043  
Radio Communication Equipment Weight Fraction 0.0022  
Instrument Equipment Weight Fraction 0.0050  
Fuel System Weight Fraction 0.0103

Additional Equipment:

Equipment for Container Loading 0.0064  
No typical Equipment Weight Fraction 0.0035  
(Build-in Test Equipment for Fault Diagnosis,  
Additional Equipment of Passenger Cabin)

TAKEOFF DISTANCE PARAMETERS

Airplane Lift-off Speed 281.95km/h

Acceleration during Takeoff Run 2.33m/s<sup>2</sup>  
Airplane Takeoff Run Distance 1311m  
Airborne Takeoff Distance 578m  
Takeoff Distance

CONTINUED TAKEOFF DISTANCE PARAMETERS

Decision Speed 267.85km/h

Mean Acceleration for Continued Takeoff on Wet Runway 0.3m/s<sup>2</sup>  
Takeoff Run Distance for Continued Takeoff on Wet Runway 2149.39m  
Continued Takeoff Distance 2727.77m  
Runway Length Required for Rejected Takeoff 2826.12m

LANDING DISTANCE PARAMETERS

Airplane Maximum Landing Weight 86041kg

Time for Descent from Flight Level till Aerodrome Traffic Circuit Flight 218min  
Descent Distance 51.38km  
Approach Speed 246.19km/h  
Mean Vertical Speed 1.99m/s  
Airborne Landing Distance 515  
Landing Speed 231.19km/h  
Landing run distance 714m  
Landing Distance 1230m  
Runway Length Required for Regular Aerodrome 2053m  
Runway Length Required for Alternate Aerodrome 1746m

# Appendix B

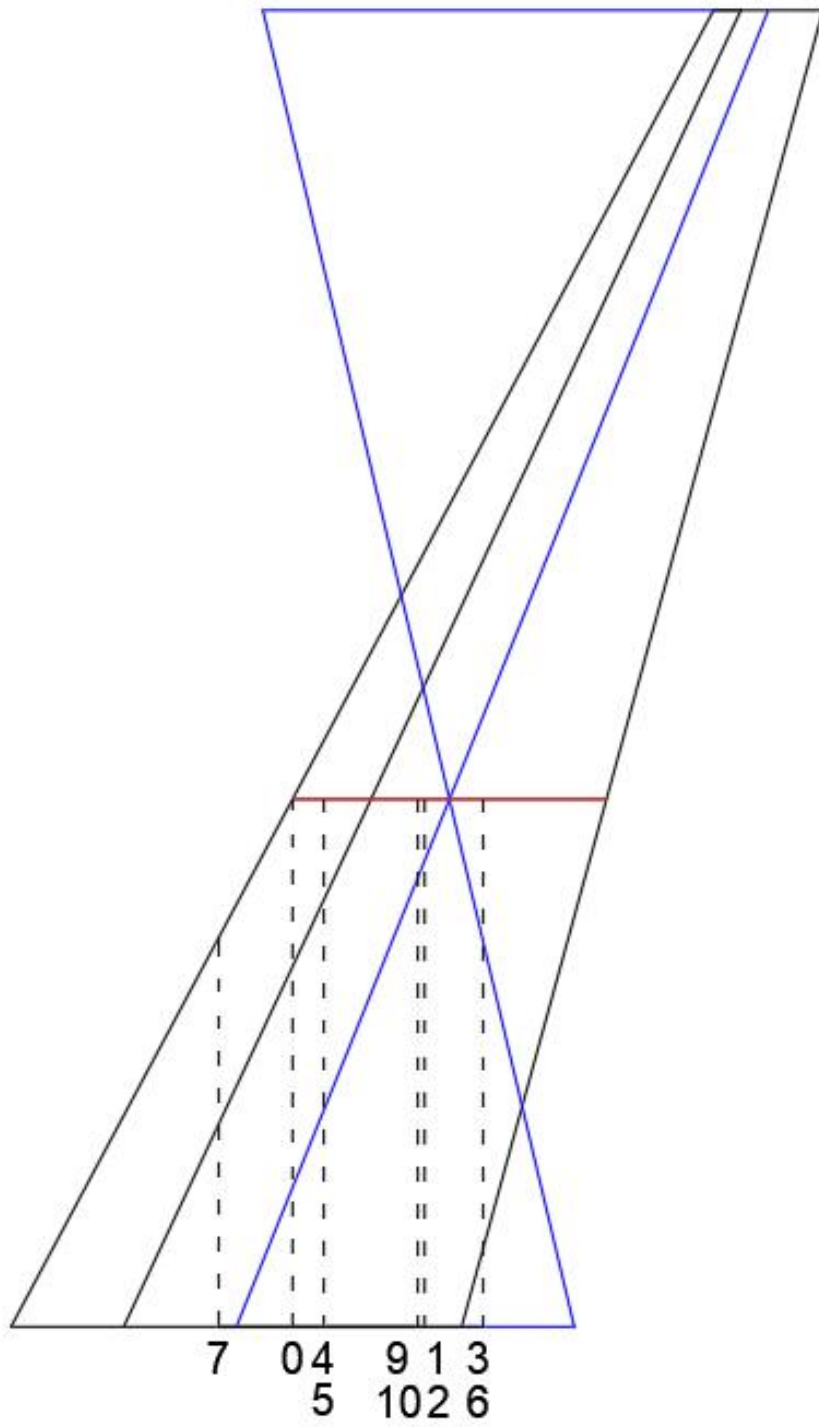

# Appendix C

