

Ministry of Education and Science of Ukraine

National Aviation University

## **Lecture Notes**

compiler O.Bashta

## **Subject and tasks of metrology**

1. Subject of Metrology
2. Physical quantities and their units
3. The international system of units
4. A metrology system creation

### **1. Subject of Metrology**

**Metrology** is the [science](#) of [measurement](#). Metrology includes all theoretical and practical aspects of measurement.

Metrology is defined by the [International Bureau of Weights and Measures](#) (BIPM) as "the science of measurement, embracing both [experimental](#) and [theoretical](#) determinations at any level of [uncertainty](#) in any field of science and technology."<sup>[1]</sup> The [ontology](#) and [international vocabulary of metrology](#) (VIM) is maintained by the International Organisation for Standardisation.

The **International Bureau of Weights and Measures** ([French](#): *Bureau international des poids et mesures*), is an international [standards organisation](#), one of three such organisations established to maintain the [International System of Units](#) (SI) under the terms of the [Metre Convention](#) (*Convention du Mètre*). The organisation is usually referred to by its French [initialism](#), **BIPM**.

The other organisations that maintain the SI system, also known by their French initialisms are the [General Conference on Weights and Measures](#) ([French](#): *Conférence générale des poids et mesures*) (CGPM) and the [International Committee for Weights and Measures](#) ([French](#): *Comité international des poids et mesures*) (CIPM).

**Measurement** - finding values of physical quantities experimentally.

**Quantity** - property of a phenomenon, body, or substance, where the property has a magnitude that can be expressed as a number and a reference

**The unity of measurements** - this state when measuring physical quantities are expressed in terms of legitimate and known values of their errors with a given probability.

**The basic issues of metrology are:**

1. The general theory of measurement;
2. Units of physical quantities and their systems;
3. Methods and means of measurement;
4. Methods for determining the accuracy of measurements;
5. Principles of unity and uniformity of measurements of the measurement instruments;
6. Methods of transmission units, from the standards or model of measuring working means of measurement.

Metrology is a very broad field and may be divided into three subfields:

Subfield	Definition
Scientific fundamental metrology	or concerns the establishment of <a href="#">quantity systems</a> , unit systems, <a href="#">units of measurement</a> , the development of new measurement methods, realisation of measurement standards and the transfer of traceability from these standards to

		users in society.
Applied industrial metrology	or	concerns the application of measurement science to manufacturing and other processes and their use in society, ensuring the suitability of measurement instruments, their calibration and quality control of measurements.
Legal metrology		concerns regulatory requirements of measurements and measuring instruments for the protection of health, public safety, the environment, enabling taxation, protection of consumers and fair trade.

Metrology operates a number of terms set DSTU 2681-94 "Metrology. Terms and definitions ". This standard sets the requirements for usage of terms in all kinds of documentation, scientific, educational literature, which belongs to metrology and metrological support, and work on standardization, or when using the results of these works, including software for computers' computer systems.

Here are the characteristics of the most used of standardized terms:

*фізична величина* - властивість, спільна в якісному відношенні для багатьох матеріальних об'єктів та індивідуальна в кількісному відношенні для кожного з них;

**quantity** property of a phenomenon, body, or substance, where the property has a magnitude that can be expressed as a number and a reference.

The concept 'quantity' may be generically divided into, e.g. 'physical quantity', 'chemical quantity', and 'biological quantity', or base quantity and derived quantity.

*розмір (фізичної) величини* - кількісний вміст фізичної величини в даному об'єкті;

**kind of quantity** aspect common to mutually comparable quantities.

NOTE 1 The division of the concept of 'quantity' according to 'kind of quantity' is to some extent arbitrary.

EXAMPLE 1 The quantities diameter, circumference, and wavelength are generally considered to be quantities of the same kind, namely of the kind of quantity called length.

EXAMPLE 2 The quantities heat, kinetic energy, and potential energy are generally considered to be quantities of the same kind, namely of the kind of quantity called energy.

*значення (фізичної) величини* - відображення фізичної величини у вигляді числового значення величини із позначенням її одиниці;

*істинне значення (фізичної величини)* - значення фізичної величини, яке ідеально відображало б певну властивість об'єкта;

*умовно істинне значення (фізичної величини)* - значення фізичної величини, знайдене експериментальним шляхом і настільки наближене до істинного значення, що його можна використати замість істинного для даної мети (*дійсне значення*);

*система (фізичних) величин* - сукупність взаємопов'язаних фізичних величин, в якій декілька величин приймають за незалежні, а інші визначають як залежні від них;

**system of quantities** set of quantities together with a set of noncontradictory equations relating those quantities

NOTE Ordinal quantities, such as Rockwell C hardness, are usually not considered to be part of a system of quantities because they are related to other quantities through empirical relations only.

*основна (фізична) величина* - фізична величина, що входить до системи фізичних величин і прийнята за незалежну від інших величин цієї системи;

**base quantity** quantity in a conventionally chosen subset of a given system of quantities, where no subset quantity can be expressed in terms of the others.

NOTE 2 Base quantities are referred to as being mutually independent since a base quantity cannot be expressed as a product of powers of the other base quantities.

*похідна (фізична) величина* - фізична величина, що входить до системи величин та визначається через основні величини цієї системи;

**derived quantity** quantity, in a system of quantities, defined in terms of the base quantities of that system

EXAMPLE In a system of quantities having the base quantities length and mass, mass density is a derived quantity defined as the quotient of mass and volume (length to the third power).

*розмірність фізичної величини* - вираз, що відображає її зв'язок із основними величинами системи;

*одиниця (фізичної) величини* - фізична величина певного розміру, прийнята за угодою для кількісного відображення однорідних з нею величин;

*числове значення (фізичної) величини* - число, що дорівнює відношенню розміру фізичної величини, що вимірюється, до розміру одиниці цієї фізичної величини чи кратної одиниці;

## **2. Physical quantities and their units**

There are an unlimited number of [derived units](#) formed from multiplication and division of the seven base units; <sup>[12]</sup> for example, the SI derived unit of speed is metre per second, m/s. Some derived units have special names; for example, the unit of resistance, the ohm, symbol  $\Omega$ , is uniquely defined by the relation  $\Omega = \text{m}^2 \cdot \text{kg} \cdot \text{s}^{-3} \cdot \text{A}^{-2}$ , which follows from the definition of the quantity [electrical resistance](#). The [radian](#) and [steradian](#), once given special status, are now considered derived units. <sup>[12]</sup>

Technical measurement is an integral part of applied metrology.

The process of measurement is characterized on the one hand, perception and reflection of a physical quantity, and on the other - normalization, i.e. the assignment of a numerical value (size), which is expressed in the adopted units.

The values of quantities should not be equated with the size.

The size of the physical quantity of the object really exists and whether we know or not express it in any terms. The value of the same physical quantity appears only after the size value of this object is expressed by a particular unit.

The values of physical quantities get due to reach the measurement or calculation.

## Writing unit symbols and the values of quantities

- The value of a quantity is written as a number followed by a space (representing a multiplication sign) and a unit symbol; e.g., "2.21 kg", "7.3×10<sup>2</sup> m<sup>2</sup>", "22 K". This rule explicitly includes the percent sign (%). Exceptions are the symbols for plane angular degrees, minutes and seconds (°, ' and "), which are placed immediately after the number with no intervening space. <sup>[13][14]</sup>
- Symbols for derived units formed by multiplication are joined with a [centre dot](#) (·) or a non-break space, for example, "N·m" or "N m".
- Symbols for derived units formed by division are joined with a [solidus](#) (/), or given as a negative [exponent](#). For example, the "metre per second" can be written "m/s", "m s<sup>-1</sup>", "m·s<sup>-1</sup>" or  $\frac{\text{m}}{\text{s}}$ . Only one [solidus](#) should be used; e.g., "kg/(m·s<sup>2</sup>)" or "kg·m<sup>-1</sup>·s<sup>-2</sup>" are acceptable but "kg/m/s<sup>2</sup>" is ambiguous and unacceptable. Many computer users will type the / character provided on [computer keyboards](#), which in turn produces the [Unicode](#) character U+002F, which is named solidus but is distinct from the Unicode solidus character, U+2044.
- Symbols are mathematical entities, not abbreviations, and do not have an appended period/full stop (.).
- Symbols are written in upright ([Roman](#)) type (m for metres, s for seconds), so as to differentiate from the [italic type](#) used for variables (*m* for mass, *s* for displacement). By consensus of international standards bodies, this rule is applied independent of the font used for surrounding text. <sup>[15]</sup>
- Symbols for units are written in [lower case](#) (e.g., "m", "s", "mol"), except for symbols derived from the name of a person. For example, the unit of [pressure](#) is named after [Blaise Pascal](#), so its symbol is written "Pa", whereas the [unit](#) itself is written "[pascal](#)". <sup>[16]</sup>
  - The one exception is the [litre](#), whose original symbol "l" is unsuitably similar to the numeral "1" or the uppercase letter "I" (depending on the typeface used), at least in many [English-speaking countries](#). The American [National Institute of Standards and Technology](#) recommends that "L" be used instead, a usage which is common in the US, Canada and Australia (but not elsewhere). This has been accepted as an alternative by the [CGPM](#) since 1979. The cursive ℓ is occasionally seen, especially in Japan and Greece, but this is not currently recommended by any [standards body](#). For more information, see [litre](#).
- A prefix is part of the unit, and its symbol is prepended to the unit symbol without a separator (e.g., "k" in "km", "M" in "MPa", "G" in "GHz"). Compound prefixes are not allowed.
- All symbols of prefixes larger than 10<sup>3</sup> (kilo) are uppercase. <sup>[17]</sup>
- Symbols of units are not pluralised; e.g., "25 kg", not "25 kgs". <sup>[15]</sup>
- The 10th resolution of [CGPM](#) in 2003 declared that "the symbol for the [decimal marker](#) shall be either the [point](#) on the line or the [comma](#) on the line." In practice, the decimal point is used in English-speaking countries as well as most of Asia and the comma in most continental [European languages](#).
- Spaces may be used as a [thousands separator](#) (1000000) in contrast to commas or periods (1,000,000 or 1.000.000) in order to reduce confusion resulting from the variation between these forms in different countries. [In print](#), the space used for this purpose is typically narrower than that between words (commonly a [thin space](#)).

### **3. The international system of units**

**International System of Quantities (ISQ)** system of quantities based on the seven base

quantities: length, mass, time, electric current, thermodynamic temperature, amount of substance, and luminous intensity.

SI base units<sup>[10][11]</sup>

Name	Unit symbol	Quantity	Symbol
<a href="#">metre</a>	m	<a href="#">length</a>	<i>l</i> (a lowercase L)
<a href="#">kilogram</a> <sup>[Notes 1]</sup>	kg	<a href="#">mass</a>	<i>M</i>
<a href="#">second</a>	s	<a href="#">time</a>	<i>T</i>
<a href="#">ampere</a>	A	<a href="#">electric current</a>	<i>I</i> (a capital i)
<a href="#">kelvin</a>	K	<a href="#">thermodynamic temperature</a>	<i>T</i>
<a href="#">candela</a>	cd	<a href="#">luminous intensity</a>	<i>I<sub>v</sub></i> (a capital i with lowercase v subscript)
<a href="#">mole</a>	mol	<a href="#">amount of substance</a>	<i>N</i>

A [prefix](#) may be added to a unit to produce a multiple of the original unit. All multiples are integer powers of ten, and beyond a hundred(th) all are integer powers of a thousand. For example, *kilo-* denotes a multiple of a thousand and *milli-* denotes a multiple of a thousandth; hence there are one thousand millimetres to the metre and one thousand metres to the kilometre. The prefixes are never combined: a millionth of a metre is a *micrometre* not a *millimillimetre*.

#### [Standard prefixes for the SI units of measure](#)

Name	<a href="#">deca-</a>	<a href="#">hecto-</a>	<a href="#">kilo-</a>	<a href="#">mega-</a>	<a href="#">giga-</a>	<a href="#">tera-</a>	<a href="#">peta-</a>	<a href="#">exa-</a>	<a href="#">zetta-</a>	<a href="#">yotta-</a>	
<b>Multiples</b>	da	h	k	M	G	T	P	E	Z	Y	
<b>Factor</b>	10 <sup>0</sup>	10 <sup>1</sup>	10 <sup>2</sup>	10 <sup>3</sup>	10 <sup>6</sup>	10 <sup>9</sup>	10 <sup>12</sup>	10 <sup>15</sup>	10 <sup>18</sup>	10 <sup>21</sup>	10 <sup>24</sup>

Name	<a href="#">deci-</a>	<a href="#">centi-</a>	<a href="#">milli-</a>	<a href="#">micro-</a>	<a href="#">nano-</a>	<a href="#">pico-</a>	<a href="#">femto-</a>	<a href="#">atto-</a>	<a href="#">zepto-</a>	<a href="#">yocto-</a>	
<b>Fractions</b>	d	c	m	μ	n	p	f	a	z	y	
<b>Factor</b>	10 <sup>0</sup>	10 <sup>-1</sup>	10 <sup>-2</sup>	10 <sup>-3</sup>	10 <sup>-6</sup>	10 <sup>-9</sup>	10 <sup>-12</sup>	10 <sup>-15</sup>	10 <sup>-18</sup>	10 <sup>-21</sup>	10 <sup>-24</sup>

#### **4. Утворення метрологічної системи.**

До кінця XVIII століття у Франції і в інших країнах існувала велика кількість одиниць виміру одних і тих же фізичних величин і мір, що гальмувало розвиток промисловості і торгівлі.

8 травня 1790 року Національні збори Франції прийняли Декрет про реформу системи мір і доручили Паризькій академії наук провести необхідні підготовчі роботи по заснуванню метричної системи.

22 червня 1799 року ці роботи було завершено. Так був встановлений метр (1/10 000 000 частина чверті земного меридіана), і друга одиниця метричної системи – одиниця ваги – кілограм (вага у вакуумі кубічного дециметра дистильованої води при її найбільшій щільності (4<sup>0</sup>C), який знаходиться на рівні моря і на широті 45<sup>0</sup>). Прототипи метра і кілограма було передано законодавчому корпусу, а потім – на збереження Національному архіву Франції. Відтоді ці

прототипи іменуються «архівними».

У першій половині XIX століття метрична система мір почала впроваджуватися у Франції, а незабаром і в інших країнах.

## Lecture 2

### **Industrial and scientific metrology**

Metrological activities, calibration, testing and measurements are valuable inputs to ensure the quality of many industrial and quality of life related activities and processes.

This includes the need to demonstrate traceability, which is becoming just as important as the measurement itself. Recognition of metrological competence at each level of the traceability chain can be established through mutual recognition agreements or arrangements.

#### **Subject fields**

Scientific metrology is divided into 9 technical subject fields by BIPM: Acoustics, amount of substance, electricity and magnetism, ionising radiation and radioactivity, length, mass, photometry and radiometry, thermometry, time and frequency.

Within EURAMET there are three additional subject fields: flow, interdisciplinary metrology and quality.

\* The **European Association of National Metrology Institutes** (EURAMET) is a Regional Metrology Organisation (RMO) of Europe. It coordinates the cooperation of National Metrology Institutes (NMI) of Europe in fields like research in metrology, traceability of measurements to the SI units, international recognition of national measurement standards and related Calibration and Measurement Capabilities (CMC) of its members. Through Knowledge Transfer and cooperation among its members EURAMET facilitates the development of the national metrology infrastructures.

EURAMET is responsible for the elaboration and execution of the **European Metrology Research Programme** (EMRP) which is designed to encourage collaboration between European National Metrology Institutes (NMIs) and partners in industry or academia. The programme funds joint research projects in specific fields of metrology with over 50 projects selected for funding so far and many more expected over the coming years.

There is no formal international definition of the subfields.

*Table 1:* Subject fields, subfields and important measurement standards.

Only technical subject fields are included.

<b>SUBJECT FIELD</b>	<b>SUBFIELD</b>	<b>IMPORTANT MEASUREMENT STANDARDS</b>
<b>MASS AND RELATED QUANTITIES</b>	Mass measurement	Mass standards, standard balances, mass comparators
	Force and pressure	Load cells, dead-weight testers, force, moment and torque converters, pressure balances with oil/gas-lubricated piston cylinder assemblies, force-testing machines, capacitance manometers, ionisation gauges
	Volume and density Viscosity	Glass areometers, laboratory glassware, vibration densimeters, glass capillary viscometers, rotation viscometers,



<b>SUBJECT FIELD</b>	<b>SUBFIELD</b>	<b>IMPORTANT MEASUREMENT STANDARDS</b>
<b>ELECTRICITY AND MAGNETISM</b>	DC electricity	Cryogenic current comparators, Josephson effect and Quantum Hall effect, Zener diode references, potentiometric methods, comparator bridges
	AC electricity	AC/DC converters, standard capacitors, air capacitors, standard inductances, compensators, wattmeters
	HF electricity	Thermal converters, calorimeters, bolometers
	High current and high voltage	Measurement transformers of current and voltage, reference high voltage sources
<b>LENGTH</b>	Wavelengths and interferometry	Stabilized lasers, interferometers, laser interferometric measurement systems, interferometric comparators
	Dimensional metrology	Gauge blocks, line scales, step gauges, setting rings, plugs, high masters, dial gauges, measuring microscopes, optical flat standards, coordinate measuring machines, laser scan micrometers, depth micrometers, geodetic length measuring tools
	Angular measurements	Autocollimators, rotary tables, angle gauges, polygons, levels
	Form	Straightness, flatness, parallelism, squares, roundness standards, cylinder standards
	Surface Quality	Step height and groove standards, roughness standards, roughness measurement equipment
<b>TIME AND FREQUENCY</b>	Time measurement	Caesium atomic clock, time interval equipment
	Frequency	Atomic clock and fountain, quartz oscillators, lasers, electronic counters and synthesisers, optical combs
<b>THERMOMETRY</b>	Temperature measurement by contact	Gas thermometers, ITS 90 fixed points, resistance thermometers, thermocouples
	Non-contact temperature measurement	High-temperature black bodies, cryogenic radiometers, pyrometers, Si photodiodes
	Humidity	Mirror dew point meters or electronic hygrometers, double pressure/temperature humidity generators

<b>SUBJECT FIELD</b>	<b>SUBFIELD</b>	<b>IMPORTANT MEASUREMENT STANDARDS</b>
<b>THERMOMETRY</b>	Absorbed dose – Medical products	Calorimeters, Ionisation chambers
	Radiation protection	Ionisation chambers, reference radiation beams/fields, proportional and other counters, TEPC, Bonner neutron spectrometers
	Radioactivity	Well-type ionising chambers, certified radioactivity sources, gamma and alpha spectroscopy, 4 $\pi$ detectors
<b>PHOTOMETRY AND RADIOMETRY</b>	Optical radiometry	Cryogenic radiometer, optical detectors, stabilised laser reference sources, reference materials
	Photometry	Visible region detectors, Si photodiodes, quantum efficiency detectors
	Colorimetry	Spectrophotometer
	Optical fibres	Reference materials
<b>FLOW</b>	Gas flow (volume)	Bell provers, rotary gas meters, turbine gas meters, transfer meter with critical nozzles
	Flow of liquids (volume, mass and energy)	Volume standards, Coriolis mass-related standards, level meters, inductive flow meters, ultrasound flow meters
	Anemometry	Anemometers
<b>ACOUSTICS, ULTRASOUND AND VIBRATION</b>	Acoustical measurements in gases	Standard microphones, piston phones, condenser microphones, sound calibrators
	Accelerometry	Accelerometers, force transducers, vibrators, laser interferometer
	Acoustical measurements in liquids	Hydrophones
	Ultrasound	Ultrasonic power meters, radiation force balance
<b>CHEMISTRY</b>	Environmental chemistry Clinical chemistry	Certified reference materials, mass spectrometers, chromatographs, gravimetric standards
	Materials chemistry	Pure materials, certified reference materials
	Food chemistry, Biochemistry, Micro biology	Certified reference materials
	pH measurement	Certified reference materials, standard electrodes

## Measurement standards

A measurement standard or etalon, is a material measure, measuring instrument, reference material or measuring system intended to define, realise, conserve or reproduce a unit or one or more values of a quantity to serve as a reference.

**Example** The metre is defined as the length of the path travelled by light in vacuum during a time interval of  $1/299\,792\,458$  of a second. The metre is realized at the primary level in terms of the wavelength from an iodine-stabilised helium-neon laser. On sub-levels, material measures like gauge blocks are used, and traceability is ensured by using optical interferometry to determine the length of the gauge blocks with reference to the abovementioned laser light wavelength.

The different levels of measurement standard are shown in Figure 1.

There is no international listing of all measurement standards.

**Figure 1: The traceability chain**

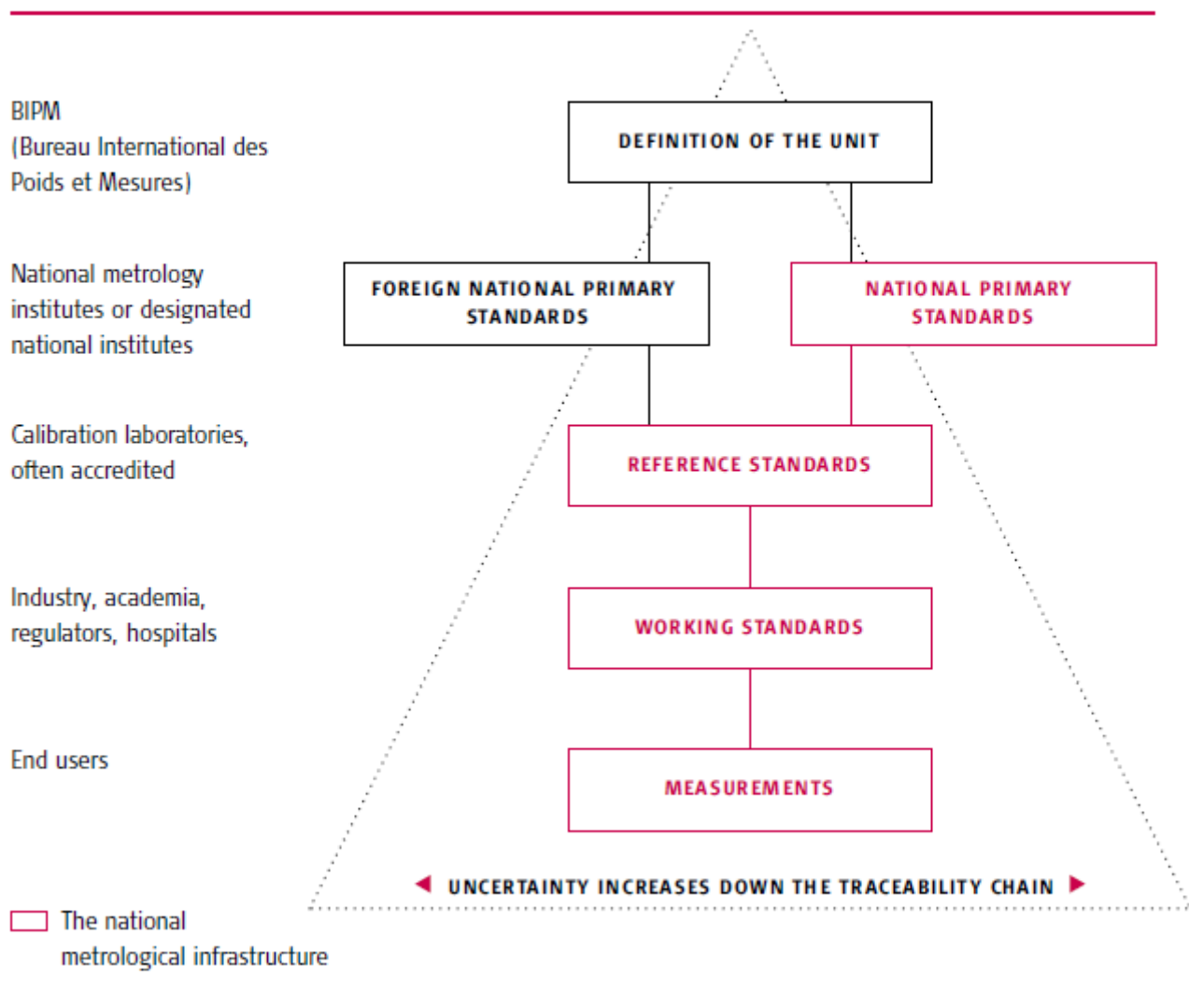

## Certified reference materials

A certified reference material (CRM) is a reference material, where one or more of its property values are certified by a procedure that establishes traceability to a realisation of the unit, in which the property values are expressed. Each certified value is accompanied by an uncertainty at a stated level of confidence. The term standard reference material (SRM) is also used in some parts of the world and is synonymous with a CRM.

CRMs are generally prepared in batches. The property values are determined within stated uncertainty limits by measurements on samples representative of the whole batch.

## What is a standard?

Standard: A standard is a material measure or physical property that defines or reproduces the unit of measurement of a base or derived quantity.

However, a standard also needs to be checked against a higher standard to establish its accuracy and traceability. Since the same argument would hold good even for the higher standard, this hierarchy of standards must lead to a level above which comparison is not possible.

## Hierarchy of standards

The comparison of standards stops with the absolute or fundamental standard. Once that fact is understood and accepted, it is not difficult to ensure comparison of the next-level standards.

*Fundamental or absolute standard: One whose value has been established without recourse to another standard of the same quantity.*

*International standard: One recognized by international agreement as the basis for fixing the values of all other standards of the given quantity.*

*National or primary standard: One which establishes the value of all other standards of a given quantity within a particular country.*

*Secondary standard: One whose value has been established by comparison with a primary standard.*

*Working standard: A secondary standard used to verify measuring instruments in places such as factories, shops, etc.*

By international agreement reached amongst the various standardization bodies of the world, there are seven absolute standards. These are:

<i>Quantity</i>	<i>Unit</i>	<i>Symbol</i>
Length	Metre	m
Mass	Kilogram	Kg
Time	Second	s
Electric current	Ampere	A
Temperature	Kelvin	K
Substance	Mole	mol
Luminous intensity	Candela	cd

In addition, there are two supplementary standards, which are:

<i>Quantity</i>	<i>Unit</i>	<i>Symbol</i>
Plane angle	Radian	rad
Solid angle	Steradian	sr

All the other standards are derived from the base units. Some of these are listed below:

Quantity	Unit	Symbol	Formula
Frequency	Hertz	Hz	S <sup>-1</sup>
Force	Newton	N	M.kg/s <sup>2</sup>
Pressure	Pascal	Pa	N/m <sup>2</sup>
Energy	Joule	J	Nm
Power	Watt	W	J/s
Electric potential	Volt	V	W/A

Standards, however, do not exist for many parameters. While some of these are engineering parameters, a large number of parameters are concerned with chemical and pharmaceutical measurements. In such cases, valid calibration is performed against reference standards, reference material, certified reference material or consensus industry standards. These alternative standards are explained below.

*Reference standard: the best locally available standard from which measurements made at a location are derived.*

*Reference material: material sufficiently homogeneous and stable with respect to one or more specified quantities, used for the calibration of a measuring system, for the assessment of a measurement procedure, or for assigning values and measurement uncertainties to quantities of the same kind for other materials. A reference material can be in the form of, for example, a pure or mixed gas, in liquid, solid or suspension form.*

*Certified reference material: reference material accompanied by an authenticated certificate, having for each specified quantity a value, measurement uncertainty and stated metrological traceability chain.*

### **Absolute standards**

Definitions of the seven absolute standards are given below. The year within parentheses indicates the last revision or the agreement date.

*Second (1967):* The duration of 9,192,631,770 periods of the radiation corresponding to the transition between two hyperfine levels of the ground state of the cesium-133 atom.

*Metre (1983):* The length of the path travelled by light in vacuum during the time interval of 1/299792458 of a second.

*Ampere (1948):* The constant current that, if maintained in two straight parallel conductors of infinite length and of negligible cross-section, and placed 1 metre apart in a vacuum, would produce between these conductors a force equal to  $2 \times 10^{-7}$  newtons per metre of length.

*Kilogram (1901):* The mass of the international prototype, which is in the custody of the International Bureau of Weights and Measures at Se'vres, near Paris.

*Kelvin (its 90):* The fraction 1/273.16 of the thermodynamic temperature of the triple point of water.

*Candela (1979):* The luminous intensity, in a given direction, of a source that emits monochromatic radiation of frequency  $540 \times 10^{12}$  hertz and has a radiant intensity of 1/683 watt per steradian in that direction.

*Mole (1971):* The amount of substance of a system which contains as many elementary entities as there are atoms in 0.12 kilogram of carbon atom.

# Лекція

## Методи та одиниці вимірювання

### **Measurement** , m

process of experimentally obtaining one or more

quantity values that can reasonably be to a quantity

NOTE 1 Measurement does not apply to nominal properties.

NOTE 2 Measurement implies comparison of quantities and includes counting of entities.

NOTE 3 Measurement presupposes a description of the quantity commensurate with the intended use of a measurement result, a measurement procedure, and calibrated measuring system operating according to the specified measurement procedure, including the measurement conditions.

### **Metrology**

science of measurement and its application

NOTE Metrology includes all theoretical and practical aspects of measurement, whatever the measurement uncertainty and field of application.

### **Measurand**

quantity intended to be measured

NOTE 1 The specification of a measurand requires knowledge of the kind of quantity, description of the state of the phenomenon, body, or substance carrying the quantity, including any relevant component, and the chemical entities involved.

NOTE 2 In the second edition of the VIM and in IEC 60050-300:2001, the measurand is defined as the 'quantity subject to measurement'.

NOTE 3 The measurement, including the measuring system and the conditions under which the measurement is carried out, might change the phenomenon, body, or substance such that the quantity being measured may differ from the measurand as defined. In this case, adequate correction is necessary.

EXAMPLE 1 The potential difference between terminals of a battery may decrease when using a voltmeter with a significant internal conductance to perform the measurement. The open-circuit potential difference can be calculated from the internal resistances of the battery and the voltmeter.

EXAMPLE 2 The length of a steel rod in equilibrium with the ambient Celsius temperature of 23 °C will be different from the length at the specified temperature of 20 °C, which is the measurand. In this case, a correction is necessary

NOTE 4 In chemistry, "analyte", or the name of a substance or compound, are terms sometimes used for 'measurand'. This usage is erroneous because these terms do not refer to quantities.

### **Measurement principle**

principle of measurement phenomenon serving as a basis of a measurement

EXAMPLE 1 Thermoelectric effect applied to the measurement of temperature.

EXAMPLE 2 Energy absorption applied to the measurement of amount-of-substance concentration.

EXAMPLE 3 Lowering of the concentration of glucose in blood in a fasting rabbit applied to the measurement of insulin concentration in a preparation.

NOTE The phenomenon can be of a physical, chemical, or biological nature.

### **Measurement method**

method of measurement generic description of a logical organization of operations used in a measurement

NOTE Measurement methods may be qualified in various ways such as:

- substitution measurement method,
- differential measurement method, and
- null measurement method;
- direct measurement method, and
- indirect measurement method.

See IEC 60050-300:2001.

### **Measurement procedure**

detailed description of a measurement according to one or more measurement principles and to a given measurement method, based on a measurement model and including any calculation to obtain a measurement result

NOTE 1 A measurement procedure is usually documented in sufficient detail to enable an operator to perform a measurement.

NOTE 2 A measurement procedure can include a statement concerning a target measurement uncertainty.

NOTE 3 A measurement procedure is sometimes called a standard operating procedure, abbreviated SOP.

### **Reference measurement procedure**

measurement procedure accepted as providing measurement results fit for their intended use in assessing measurement trueness of measured quantity values obtained from other measurement procedures for quantities of the same kind, in calibration, or in characterizing reference materials

### **Primary reference measurement procedure**

primary reference procedure is reference measurement procedure used to obtain a measurement result without relation to a measurement standard for a quantity of the same kind

EXAMPLE The volume of water delivered by a 5 ml pipette at 20 °C is measured by weighing the water delivered by the pipette into a beaker, taking the mass of beaker plus water minus the mass of the initially empty water temperature using the volumic mass (mass density).

NOTE 1 The Consultative Committee for Amount of Substance – Metrology in Chemistry (CCQM) uses the term “primary method of measurement” for this concept.

NOTE 2 Definitions of two subordinate concepts, which could be termed “direct primary reference measurement procedure” and “ratio primary reference measurement procedure”, are given by the CCQM (5th Meeting, 1999) [43].

### **Measurement result**

result of measurement set of quantity values being attributed to a measurand together with any other available relevant information disponible

NOTE 1 A measurement result generally contains “relevant information” about the set of quantity values, such that some may be more representative of the measurand than others. This may be expressed in the form of a probability density function (PDF).

NOTE 2 A measurement result is generally expressed as a single measured quantity value and a measurement uncertainty. If the measurement uncertainty is considered to be negligible for some purpose, the measurement result may be expressed as a single measured quantity value. In many fields, this is the common way of expressing a measurement result.

NOTE 3 In the traditional literature and in the previous edition of the VIM, measurement result was defined as a value attributed to a measurand and explained to mean an indication, or an uncorrected result, or a corrected result, according to the context.

### **Measured quantity value**

measured value of a quantity representing a measurement result

NOTE 1 For a measurement involving replicate indications, each indication can be used to provide a corresponding measured quantity value. This set of individual measured quantity values can be used to calculate a resulting measured quantity value, such as an average or median, usually with a decreased associated measurement uncertainty.

NOTE 2 When the range of the true quantity values believed to represent the measurand is small compared with the measurement uncertainty, a measured quantity value can be considered to be an estimate of an essentially unique true quantity value and is often an average or through replicate measurements.

NOTE 3 In the case where the range of the true quantity values believed to represent the measurand is not small compared with the measurement uncertainty, a measured value is often an estimate of an average or median of the set of true quantity values.

NOTE 4 In the GUM, the terms “result of measurement” and “estimate of the value of the measurand” or just “estimate of the measurand” are used for ‘measured quantity value’.

### **True quantity value**

true value of a quantity consistent with the definition of a quantity

NOTE 1 In the Error Approach to describing measurement, a true quantity value is considered unique and, in practice, unknowable. The Uncertainty Approach is to recognize that, owing to the inherently incomplete amount of detail in the definition of a quantity, there is not a single true quantity value but rather a set of true quantity values consistent with the definition. However, this set of values is, in principle and in practice, unknowable. Other approaches dispense altogether with the concept of true quantity value and rely on the concept of metrological compatibility of measurement results for assessing their validity.



NOTE 2 In the special case of a fundamental constant, the quantity is considered to have a single true quantity value.

NOTE 3 When the definitional uncertainty associated with the measurand is considered to be negligible compared to the other components of the measurement uncertainty, the measurand may be considered to have an “essentially unique” true quantity value. This is the approach taken by the GUM and associated documents, where the word “true” is considered to be redundant

### **Conventional quantity value**

conventional quantity value attributed by agreement to a quantity for a given purpose

EXAMPLE 1 Standard acceleration of free fall (formerly called “standard acceleration due to gravity”),  $g$

$$g_n = 9.806\,65 \text{ m} \cdot \text{s}^{-2}.$$

EXAMPLE 2 Conventional quantity value of the Josephson,  $K_{J-90} = 483\,597,9 \text{ GHz} \cdot \text{V}^{-1}$ .

Josephson constant,  $K_{J-90} = 483\,597.9 \text{ GHz} \cdot \text{V}^{-1}$ .

## Лекція 3

### SELECTION OF MEASURING INSTRUMENTS

The measuring instrument is the most important part of the measurement process and the selection of the instrument therefore has to be done carefully. If the selection is not correct, the result of the measurement may give a wrong indication, thereby leading to an incorrect decision.

#### **Selection criteria**

The selection of measuring instruments depends on the measurement to be performed.

Generally, three characteristics are considered; these are:

- The range and magnitude of the parameter to be measured and the accuracy of the measurement (the instrument should have the range to cover effectively the range of the parameter).
- The resolution of the measuring instrument should be smaller than the minimum unit of measurement of the parameter.
- Lastly, and most importantly, the accuracy or uncertainty of the measuring instrument should comply with the accuracy requirement of the parameter to be measured.

For example, if a process temperature of 100°C is being measured, the range of the temperature indicator should be such that it can measure not only 100°C, but also temperatures above and below that value. Suppose the following thermometers are available:

(a) 0-99°C    (b) 0-199°C    (c) 0-99.9°C    (d) 0-199.9°C

From the range specification it is clear that the thermometers at (a) and (b) have a resolution of 1°C, while those at (c) and (d) have a resolution of 0.1°C. For measurement of the above parameter, i.e. 100°C, the thermometers at (a) and (c) above are not suitable, since these do not have the required range. The choice is therefore between (b) and (d). This would again depend on the tolerance specified for the task. If the tolerance is  $\pm 1^\circ\text{C}$ , then the thermometer at (d) above should be selected. If, on the other hand, the parameter to be measured is  $100. \pm 10.^\circ\text{C}$ , then the thermometer with a range of 0-199°C would be sufficient for the measurement.

The third important criterion for the selection of a measuring instrument is the accuracy

of measurement. The following table indicates the accuracy:

<i>Parameter to be measured</i>	<i>Accuracy of measurement</i>
100° ± 10°C	± 3°C
100° ± 1°C	± 0.3°C

The selected thermometer, when calibrated, should exhibit an accuracy that complies with the desired accuracy of measurement as demonstrated above. Alternatively, if the supplier of the thermometer provides a valid calibration certificate, the selection is easier.

From the above explanation, it is clear that unless the parameter to be measured is adequately defined, it is not possible to make a proper selection of the measuring instrument.

### **Understanding accuracy in measurement**

In order to select the correct measuring instrument, the implications of instrument accuracy on the measurement data and the effect it has on decisions taken based on the data must be clearly understood.

If the accuracy of a measuring instrument is  $\pm 1$ , this means that the value displayed on the instrument would be considered the correct value so long as the actual value of the measurement is within  $\pm 1$  of the actual value. In other words, if 10 is the reading displayed on a measuring instrument while making a measurement and if  $\pm 1$  is the accuracy of that instrument, then the actual value could be anywhere between 9 and 11, including either 9 or 11. Thus, the expanded value of the measurement can be considered as 11. Instead of direct algebraic addition, however, a better projection is that instead of 11, the expanded value is  $\sqrt{(10^2 + 1^2)} = \sqrt{(101)} = 10.05$ . Thus, the original value of 10 has now been expanded to 10.05. This is based on the statistical theory of root sum squares.

So now, instead of 11, the original value becomes 10.05 based on the accuracy of the measuring instrument. Thus, the expansion of 10 to 10.05 works out to  $100 \times (10.05 - 10) / 10 = 0.5$  per cent. It is therefore clear that when a ratio of 10:1 is maintained, the original value undergoes an expansion of 0.5 per cent in its magnitude.

Thus, if the specified tolerance on a parameter is 10 and the measuring instrument used to perform that measurement has an accuracy of 1, then the tolerance would undergo an expansion of 0.5 per cent. It would now become 10.05. So, even if all the

readings are within the tolerance of 10, we run a risk of 0.5 per cent for false acceptance or false rejection, in particular for those readings which are on the borderline of the tolerance level.

Similarly, if the specified tolerance level on a parameter is 4 and the measuring instrument has an accuracy of 1, then the effect on the tolerance based on the root sum square principle is  $\sqrt{(4^2 + 1^2)} = \sqrt{17} = 4.123$ , and the percentage expansion of the tolerance becomes  $100 \times (4.123 - 4) / 4 = 3.1$  per cent.

#### 6 Role of measurement and calibration in the manufacture of products

In the same manner, it can be shown that when this ratio is 3:1, the effect on the tolerance is 5.4 per cent. The international standards set out in International Organization for Standardization ISO 10012 and American National Standards Institute/National Conference of Standards Laboratories of America ANSI/NCSL Z540-1-1994 state that this effect of accuracy on the measurement results should be as small as possible. It should preferably be one tenth, but should not be more than one third.

This is mainly because a risk of up to about 6 or 7 per cent is considered small.

However, when this ratio becomes small, the effect or the risk becomes quite large.

For example, when this ratio is 2:1, the expanded tolerance and hence the risk becomes 11.8 per cent. If the ratio is 1:1, the risk becomes 41.4 per cent.

Thus, it is advisable to maintain a ratio of 3:1 when selecting a measuring instrument.

#### **A few examples**

*Example 1. Measurement of pressure (in kilograms of force per square centimetre)*

*Parameter to be measured Pressure gauge selected*

Range  $7.5 \pm 1.0$  kgf/cm<sup>2</sup> 0 – 10.0 kgf/cm<sup>2</sup>

Resolution Preferably 1/10 of the tolerance 0.1 kgf/cm<sup>2</sup>

Accuracy Minimum 1/3 of the tolerance  $\pm 0.25$  kgf/cm<sup>2</sup>

*Example 2. Measurement of piston diameter*

*Parameter to be measured Micrometer selected*

Range  $17.75 \pm 0.05$  mm 0 – 25.000 mm

Resolution Preferably 1/10 of the tolerance 0.001 mm

Accuracy Minimum 1/3 of the tolerance  $\pm 0.004$  mm

While for effective measurement resolution of the measuring instrument should

theoretically be one tenth of the tolerance and the accuracy of the instrument should be a minimum of one third of the tolerance, in practice selection is done based on what is generally available in the market. The selection of the instruments shown in the above examples is based on that consideration.

### **More on instrument selection**

Selection criteria, as mentioned above, should generally be followed when procuring new instruments. However, in many cases the measuring instruments are already available. In such situations, action as described below should be taken.

(a) First, the parameter being measured should be examined to check whether the tolerance and the accuracy have been stated. Next, the measuring instrument should be checked to see whether the range and the resolution are appropriate for the measurement. Lastly, the accuracy of the instrument should be checked to see whether it satisfies the specified requirement. In cases where the accuracy of the measurement is

#### **Selection of measuring instruments 7**

not specified, the instrument's accuracy should be examined to see if it is better than one third of the tolerance. If it is, then the instrument selection was appropriate.

(b) If, however, the measuring instrument's accuracy is more than one third of the tolerance of the parameter, then either of the following actions should be taken:

(i) Replace the instrument with an appropriate one, if the present system of measurement is affecting the quality of the product resulting in rejection or rework at the subsequent stage of production;

(ii) Review the specified tolerance if the existing measurement system does not affect the product quality. This means that perhaps the close tolerance specified is not needed and hence the tolerance could be increased to accommodate the accuracy of the instrument.

### **References**

1. International Organization for Standardization, "Measurement management systems: requirements for measurement processes and measuring equipment" (ISO 10012:2003).
2. American National Standards Institute/National Conference of Standards Laboratories, "Calibration laboratories and measuring and test equipment: general requirements" (ANSI/NCSL Z540-1-1994).

## **Лекція 4**

### **Похибки вимірювань**

## Лекція 5

### CALIBRATION OF MEASURING INSTRUMENTS

#### The need for calibration

Measurement is vital in science, industry and commerce. Measurement is also performed extensively in our daily life. The following are some examples:

- Measurements for health care, such as measuring body temperature with a clinical thermometer, checking blood pressure and many other tests;
- Checking the time of day;
- Buying cloth for dresses;
- Purchase of vegetables and other groceries;
- Billing of power consumption through an energy meter.

Calibration ensures that a measuring instrument displays an accurate and reliable value of the quantity being measured. Thus, calibration is an essential activity in any measurement process.

#### What is calibration?

According to the International Organization for Standardization publication entitled *International Vocabulary of Basic and General Terms in Metrology* (published in 2008 and known as VIM),

calibration is the operation that, under specified conditions, in a first step, establishes a relation between the **quantity values** with **measurement uncertainties** provided by **measurement standards** and corresponding **indications** with associated measurement uncertainties and, in a second step, uses this information to establish a relation for obtaining a **measurement result** from an indication

NOTE 1 A calibration may be expressed by a statement, calibration function, **calibration diagram**, **calibration curve**, or calibration table. In some cases, it may consist of an additive or multiplicative **correction** of the indication with associated measurement uncertainty.

Understanding of calibration is not complete without understanding traceability. In the above definition, the known values of the measurand refer to a standard. This standard must have a relationship vis-a-vis the calibration.

*Traceability: The concept of establishing valid calibration of a measuring standard or instrument by step-by-step comparison with better standards up to an accepted national or international standard.*

#### Traceability & calibration

##### Traceability to the SI

A traceability chain, see Figure 1, is an unbroken chain of comparisons, all having stated uncertainties. This ensures that a measurement result or the value of a standard is related to references at the higher levels, ending at the primary standard.

In chemistry and biology traceability is often obtained by using CRMs and reference procedures.

An end user may obtain traceability to the highest international level either directly from a National Metrology Institute or from a secondary calibration laboratory, usually an accredited laboratory. As a result of various mutual recognition arrangements, internationally recognised traceability may be obtained from laboratories outside the user's own country.

### **Calibration**

A basic tool in ensuring the traceability of a measurement is the calibration of a measuring instrument, measuring system or reference material. Calibration determines the performance characteristics of an instrument, system or reference material. It is usually achieved by means of a direct comparison against measurement standards or certified reference materials. A calibration certificate is issued and, in most cases, a sticker is provided for the instrument.

Four main reasons for having an instrument calibrated:

1. To establish and demonstrate traceability.
2. To ensure readings from the instrument are consistent with other measurements.
3. To determine the accuracy of the instrument readings.
4. To establish the reliability of the instrument i.e. that it can be trusted.

### **Reference procedures**

Reference procedures or methods can be defined as procedures of

- testing, measurement or analysis, thoroughly characterised and proven to be under control, intended for
- quality assessment of other procedures for comparable tasks, or
- characterisation of reference materials including reference objects, or
- determination of reference values.

The uncertainty of the results of a reference procedure must be adequately estimated and appropriate for the intended use.

According to this definition reference procedures can be used to

- validate other measurement or test procedures, which are used for a similar task, and to determine their uncertainty.
- determine reference values of the properties of materials, which can be compiled in handbooks or databases, or reference values which are embodied by a reference material or reference object.

## **CALIBRATION OF MEASURING INSTRUMENTS**

Essentially, calibration is a comparison with a higher standard that can be traced to a national or international standard or an acceptable alternative.

### **Measurement traceability**

In most cases, we compare two or three measurements of the same parameter to check reliability and reproducibility of the measurement. A measurement must be traceable to the acceptable standard for it to be compared. Even if it is a single measurement, traceability of the measurement is still very important.

The physical unit of measurement, in turn, should be traceable to the ultimate fundamental unit through calibration.

The following diagram gives an example of a traceability chain.



**Figure I. Traceability chain**

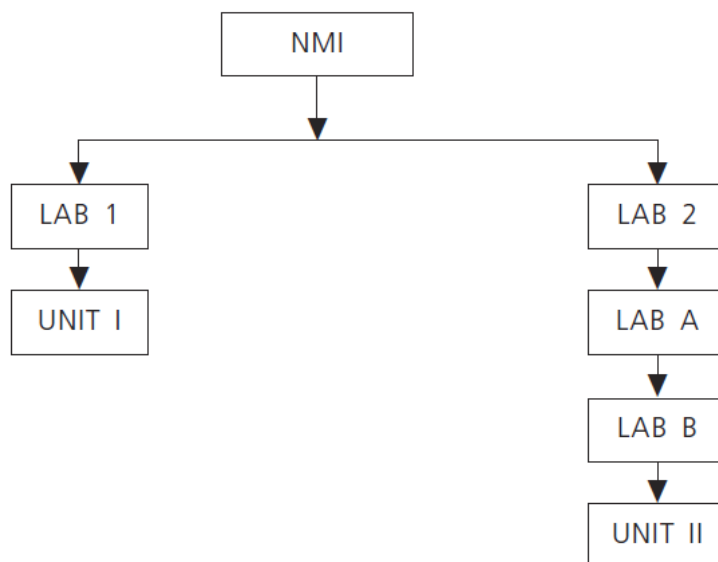

In the above case, unit 1 has had its measuring instruments calibrated by laboratory 1, whose master standards have been calibrated by the National Measurement Institute (NMI) of the country. Unit 2, on the other hand, has had its measuring Instruments calibrated at laboratory B, which has had its standard calibrated from laboratory A. Laboratory B's standards have traceability to the NMI through laboratory A and laboratory 2. Thus, both unit 1 and unit 2 have traceability to the NMI. However, error in the measurement process leading to calibration of the measuring instruments of unit 1 and unit 2 as a result of the traceability factor would be different.

### **More about calibration**

Calibration fulfils two objectives:

- It determines accuracy of the measured data
- It provides traceability to the measurement

*Calibration: Calibration is essentially the comparison, under specified conditions, with a higher standard, which is traceable to a national or international standard, or an acceptable alternative.*

### **Some examples of calibration of common parameters**

Measuring instruments for common parameters are the micrometer, the voltmeter, the pressure gauge, the temperature indicator, the weighing balance, the volumetric flask, etc. Brief methods of calibration of some of these instruments are described below.

#### ***External micrometer***

An external micrometer of a range of 0-25 mm with a resolution of 0.01 mm is shown below. The size of an object is measured on the scale together with the vernier scale readings of the thimble. Although checking of the scale accuracy is the main calibration parameter, there are three other parameters as well. These are:

- "Zero" error with the micrometer in the fully closed position;
- Flatness of the measuring surfaces, i.e. of the anvil and the spindle;
- Parallelism between the measuring surfaces.

Flatness and parallelism are checked with the help of calibrated optical flat and optical parallel devices using a monochromatic light source. Error of measurement is checked at 10 points using calibrated slip gauges.

**Figure II. External micrometer**

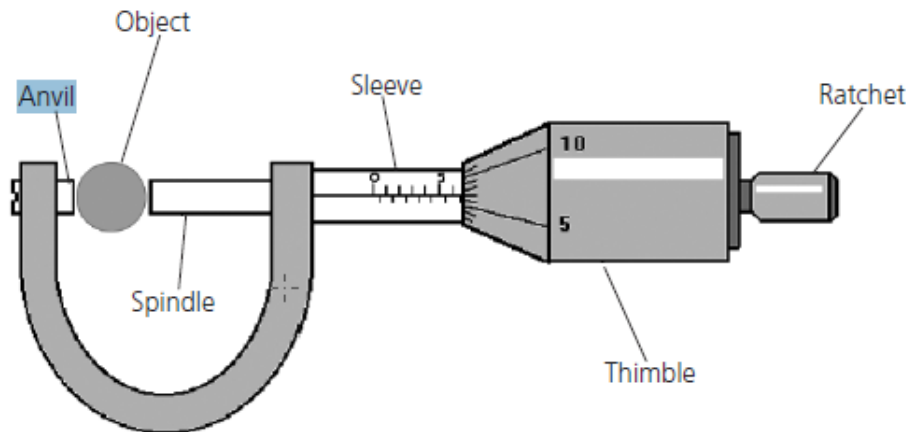

The table below shows the requirement of a micrometer generally specified in international standards.

<i>Parameter</i>	<i>Requirement (microns)</i>
Flatness of measuring surfaces, i.e. anvil and spindle	1.0 (maximum)
Parallelism of measuring surfaces, i.e. between the anvil and the spindle	$\pm (2 + A/50)$
Zero error	$\pm (2 + A/50)$
Error of measurement	$\pm (4 + A/50)$

*Note:* "A" equals the lower limit of the measuring range in mm; for a 0-25 mm size micrometer, A=0. Calibration points for checking error of measurement in a micrometer are fixed. These are: 2.5, 5.1, 7.7, 10.3, 12.9, 15.0, 17.6, 20.2, 22.8 and 25.0 mm. Irrespective of the micrometer size, these calibration points remain the same. Micrometers can also have digital readouts, but the method of calibration would be the same as described above.

### ***Voltmeter***

Voltmeters can use alternating or direct current and can be analogue or digital. Generally, calibration of these meters is done by injecting a known or a programmed quantity from a standard source at a few points covering the entire range of the voltmeter.

These standard sources, in turn, are calibrated from a higher-level laboratory with traceability to national or international standards. During calibration, the standard input is varied to the readability of the unit under calibration. This is because the standard has a better resolution than the unit. The difference between the standard input and the value shown on the unit under calibration is the error or uncertainty of the measuring instrument.

### ***Pressure gauge***

Pressure gauges can be calibrated by two methods. In the first method, a dead weight tester is used, where a pressure is first created through the piston and cylinder arrangement and then the same is balanced against calibrated weights. In this method, the balanced pressure is required to be corrected for the effect of:

- Acceleration due to gravity ("g");

- Temperature;
- Air buoyancy.

In the second method, a pressure comparator is used in which a standard pressure gauge and the unit under calibration are connected in series, so that at any given pressure the readings of both the gauges can be observed.

### ***Temperature indicator***

A temperature measuring system normally comprises:

- A sensor/thermocouple;
- A compensating cable;
- An indicator/scanner.

It can also be a composite unit such as a mercury-in-glass or an alcohol thermometer. In both cases, calibration consists of creating a stable temperature through a heating source and comparing the temperature reading of the unit under calibration and a standard thermometer.

### **Calibration in analytical measurements**

In analytical chemistry, calibration has two components:

- Calibration of measuring instruments;
- Calibration of the analytical method.

Calibration of measuring instruments is performed and measurement traceability is established to SI units in the manner explained above for thermometers, volumetric flasks, etc.

The value indicated by a measuring instrument in an analytical method could be, for example:

- The optical density of an atomic absorption spectrophotometer;
- The intensity of current delivered by a flame photometer;
- The integral of a peak in arbitrary units for a high pressure liquid chromatograph.

### **Deciphering a calibration certificate**

When a calibration certificate is received, it should be checked and assessed in the manner described below before using the instrument for measurement. Such checking should be performed on a certificate received for an existing instrument that has been sent for calibration or when buying a new instrument.

- First the certificate must correlate with the instrument. This is confirmed through matching the serial or identification number of the instrument with the number on the certificate.

- Then, the instrument's range and resolution must be examined to see whether these fulfil the measurement requirements. For example, to make a measurement of temperature of 160.5°C, the range of the measuring instrument should be 0 to 199.9°C. The resolution of the instrument should be 0.10°C

- The next parameter to be checked is the instrument's accuracy. The accuracy of the instrument or the maximum error reported on the certificate should meet the specified required accuracy of the

measurement. However, when checking the accuracy of the instrument, the uncertainty of measurement should be considered.

- From the above, it is clear that if the measurement uncertainty is not stated on the calibration certificate, no judgement can be made about the suitability of the instrument.

### **Using the knowledge**

Understanding calibration and traceability can help individuals in many ways. Some of these are mentioned below:

- Manufacturing organizations using measuring instruments will better understand the need for calibration and would be able to perform some of the minor calibrations in-house.

- When an organization is outsourcing its calibration, it would be able to ensure that such calibrations are performed correctly by monitoring the test accuracy ratio.

- Where standards traceable to SI units are not available, organizations could work towards ensuring traceability of their measurements to either a certified reference material or a reference material. Calibrations for instruments performing analytical measurement would be carried out against these materials.

- A person working in a laboratory that is preparing for accreditation under ISO/IEC 17025, would be able to appreciate the importance of traceability and could work towards ensuring traceability of all the measurements being performed.

### **References**

1. International Organization for Standardization, *International Vocabulary of Basic and General Terms in Metrology*, 2nd ed. (1993).

2. International organization for Standardization, "Measurement management systems: requirements for measurement processes and measuring equipment" (ISO 10012:2003).

3. American National Standards Institute/National Conference of Standards Laboratories, "Calibration laboratories and measuring and test equipment: general requirements" (ANSI/NCSL Z540-1-1994).

# Lecture #6

## Preferred numbers

In industrial design, preferred numbers (also called preferred values) are standard guidelines for choosing exact product dimensions within a given set of constraints. Product developers must choose numerous lengths, distances, diameters, volumes, and other characteristic quantities. While all of these choices are constrained by considerations of functionality, usability, compatibility, safety or cost, there usually remains considerable leeway in the exact choice for many dimensions.

Preferred numbers serve two purposes:

Using them increases the probability of compatibility between objects designed at different times by different people. In other words, it is one tactic among many in standardization, whether within a company or within an industry, and it is usually desirable in industrial contexts. (The opposite motive can also apply, if it is in a manufacturer's financial interest: for example, manufacturers of consumer products often have a financial interest in lack of compatibility, in planned obsolescence, and in selling name-brand and model-specific replacement parts.)

They are chosen such that when a product is manufactured in many different sizes, these will end up roughly equally spaced on a logarithmic scale. They therefore help to minimize the number of different sizes that need to be manufactured or kept in stock.

The French army engineer Col. Charles Renard proposed in the 1870s a set of preferred numbers for use with the metric system. His system was adopted in 1952 as international standard ISO 3. Renard's system of preferred numbers divides the interval from 1 to 10 into 5, 10, 20, or 40 steps. The factor between two consecutive numbers in a Renard series is constant (before rounding), namely the 5th, 10th, 20th, or 40th root of 10 (1.58, 1.26, 1.12, and 1.06, respectively), which leads to a geometric sequence. This way, the maximum relative error is minimized if an arbitrary number is replaced by the nearest Renard number multiplied by the appropriate power of 10.

The most basic R5 series consists of these five rounded numbers:

R5: 1.00    1.60    2.50    4.00    6.30

Example: If our design constraints tell us that the two screws in our gadget should be placed between 32 mm and 55 mm apart, we make it 40 mm, because 4 is in the R5 series of preferred numbers.

Example: If you want to produce a set of nails with lengths between roughly 15 and 300 mm, then the application of the R5 series would lead to a product repertoire of 16 mm, 25 mm, 40 mm, 63 mm, 100 mm, 160 mm, and 250 mm long nails.

If a finer resolution is needed, another five numbers are added to the series, one after each of the original R5 numbers, and we end up with the R10 series:

R10: 1.00 1.25 1.60 2.00 2.50 3.15 4.00 5.00 6.30 8.00

Where an even finer grading is needed, the R20, R40, and R80 series can be applied:

R20: 1.00 1.25 1.60 2.00 2.50 3.15 4.00 5.00 6.30 8.00

1.12 1.40 1.80 2.24 2.80 3.55 4.50 5.60 7.10 9.00

R40: 1.00 1.25 1.60 2.00 2.50 3.15 4.00 5.00 6.30 8.00  
1.06 1.32 1.70 2.12 2.65 3.35 4.25 5.30 6.70 8.50  
1.12 1.40 1.80 2.24 2.80 3.55 4.50 5.60 7.10 9.00  
1.18 1.50 1.90 2.36 3.00 3.75 4.75 6.00 7.50 9.50

R80: 1.00 1.25 1.60 2.00 2.50 3.15 4.00 5.00 6.30 8.00  
1.03 1.28 1.65 2.06 2.58 3.25 4.12 5.15 6.50 8.25  
1.06 1.32 1.70 2.12 2.65 3.35 4.25 5.30 6.70 8.50  
1.09 1.36 1.75 2.18 2.72 3.45 4.37 5.45 6.90 8.75  
1.12 1.40 1.80 2.24 2.80 3.55 4.50 5.60 7.10 9.00  
1.15 1.45 1.85 2.30 2.90 3.65 4.62 5.80 7.30 9.25  
1.18 1.50 1.90 2.36 3.00 3.75 4.75 6.00 7.50 9.50  
1.22 1.55 1.95 2.43 3.07 3.87 4.87 6.15 7.75 9.75

In some applications more rounded values are desirable, either because the numbers from the normal series would imply an unrealistically high accuracy, or because an integer value is needed (e.g., the number of teeth in a gear). For these needs, more rounded versions of the Renard series have been defined in ISO 3:

R5<sup>''</sup>: 1      1.5      2.5      4      6

R10<sup>'</sup>: 1    1.25 1.6 2    2.5 3.2 4    5    6.3 8

R10<sup>''</sup>: 1    1.2 1.5 2    2.5 3    4    5    6    8

R20<sup>'</sup>: 1    1.25 1.6 2    2.5 3.2 4    5    6.3 8  
1.1 1.4 1.8 2.2 2.8 3.6 4.5 5.6 7.1 9

R20<sup>''</sup>: 1    1.2 1.5 2    2.5 3    4    5    6    8  
1.1 1.4 1.8 2.2 2.8 3.5 4.5 5.5 7    9

R40<sup>'</sup>: 1    1.25 1.6 2    2.5 3.2 4    5    6.3 8

1.05 1.3 1.7 2.1 2.6 3.4 4.2 5.3 6.7 8.5

1.1 1.4 1.8 2.2 2.8 3.6 4.5 5.6 7.1 9

1.2 1.5 1.9 2.4 3 3.8 4.8 6 7.5 9.5

As the Renard numbers repeat after every 10-fold change of the scale, they are particularly well-suited for use with SI units. It makes no difference whether the Renard numbers are used with metres or kilometres. But one would end up with two incompatible sets of nicely spaced dimensions if they were applied, for instance, with both yards and miles.

Renard numbers are rounded results of the formula

,

where  $b$  is the selected series value (for example  $b = 40$  for the R40 series), and  $i$  is the  $i$ -th element of this series (with  $i = 0$  through  $i = b$ ).

[edit]Rail gauges

Only two rail gauges are preferred numbers, and these are likely accidental, but are remarkable in that they are in the R10 series whether expressed in inches or millimetres.

The more common gauge is the Irish gauge, 63 inches, which rounds to 1600 mm, both numbers in the R10 series. It is also used in Australia and Brazil. The other gauge is just half this, 800 mm or 31.5 inches, and is used by the Wengernalpbahn in Switzerland, between Lauterbrunnen and Grindelwald by way of Kleine Scheidegg.

[edit]1-2-5 series

In applications for which the R5 series provides a too fine graduation, the 1-2-5 series is sometimes used as a cruder alternative. It is effectively an R3 series rounded to one significant figure:

... 0.1 0.2 0.5 1 2 5 10 20 50 100 200 500 1000 ...

This series covers a decade (1:10 ratio) in three steps. Adjacent values differ by factors 2 or 2.5. Unlike the Renard series, the 1-2-5 series has not been formally adopted as an international standard. However, the Renard series R10 can be used to extend the 1-2-5 series to a finer graduation.

This series is used to define the scales for graphs and for instruments that display in a two-dimensional form with a graticule, such as oscilloscopes.

The denominations of most modern currencies follow a 1-2-5 series. An exception are some quarter-value coins, such as the Canadian quarter and the United States quarter (the latter denominated as "quarter dollar" rather than 25 cents). A  $\frac{1}{4}$ - $\frac{1}{2}$ -1 series (... 0.1 0.25 0.5 1 2.5 5 10 ...) is used by currencies derived from the former Dutch gulden (Aruban florin, Netherlands Antillean gulden, Surinamese dollar), some Middle Eastern currencies (Iraqi and Jordanian dinars, Lebanese pound, Syrian pound), and the Seychellois rupee. However, newer notes introduced in Lebanon and Syria due to inflation follow the standard 1-2-5 series instead.

[edit] E series

This graph shows how any value between 1 and 10 is within  $\pm 10\%$  of an E12 series value

Two decades of E12 values, which would give resistor values of 1  $\Omega$  to 82  $\Omega$

A decade of the E12 values shown with their electronic color codes on resistors.

In electronics, international standard IEC 60063 defines another preferred number series for resistors, capacitors, inductors and Zener diodes. It works similarly to the Renard series, except that it subdivides the interval from 1 to 10 into 6, 12, 24, etc. steps. These subdivisions ensure that when some arbitrary value is replaced with the nearest preferred number, the maximum relative error will be on the order of 20%, 10%, 5%, etc.

Use of the E series is mostly restricted to resistors, capacitors, inductors and zener diodes. Commonly produced dimensions for other types of electrical components are either chosen from the Renard series instead (for example fuses) or are defined in relevant product standards (for example wires).

The IEC 60063 numbers are as follows. The E6 series is every other element of the E12 series, which is in turn every other element of the E24 series:

E6 (20%): 10 15 22 33 47 68

E12 (10%): 10 12 15 18 22 27 33 39 47 56 68 82

E24 (5%): 10 12 15 18 22 27 33 39 47 56 68 82

11 13 16 20 24 30 36 43 51 62 75 91

With the E48 series, a third decimal place is added, and the values are slightly adjusted. Again, the E48 series is every other value of the E96 series, which is every other value of the E192 series:

E48 (2%): 100 121 147 178 215 261 316 383 464 562 681 825

105 127 154 187 226 274 332 402 487 590 715 866

110 133 162 196 237 287 348 422 511 619 750 909

115 140 169 205 249 301 365 442 536 649 787 953

E96 (1%): 100 121 147 178 215 261 316 383 464 562 681 825

102 124 150 182 221 267 324 392 475 576 698 845



105 127 154 187 226 274 332 402 487 590 715 866

107 130 158 191 232 280 340 412 499 604 732 887

110 133 162 196 237 287 348 422 511 619 750 909

113 137 165 200 243 294 357 432 523 634 768 931

115 140 169 205 249 301 365 442 536 649 787 953

118 143 174 210 255 309 374 453 549 665 806 976

E192 (0.5%) 100 121 147 178 215 261 316 383 464 562 681 825

101 123 149 180 218 264 320 388 470 569 690 835

102 124 150 182 221 267 324 392 475 576 698 845

104 126 152 184 223 271 328 397 481 583 706 856

105 127 154 187 226 274 332 402 487 590 715 866

106 129 156 189 229 277 336 407 493 597 723 876

107 130 158 191 232 280 340 412 499 604 732 887

109 132 160 193 234 284 344 417 505 612 741 898

110 133 162 196 237 287 348 422 511 619 750 909

111 135 164 198 240 291 352 427 517 626 759 920

113 137 165 200 243 294 357 432 523 634 768 931

114 138 167 203 246 298 361 437 530 642 777 942

115 140 169 205 249 301 365 442 536 649 787 953

117 142 172 208 252 305 370 448 542 657 796 965

118 143 174 210 255 309 374 453 549 665 806 976

120 145 176 213 258 312 379 459 556 673 816 988

The E192 series is also used for 0.25% and 0.1% tolerance resistors.

1% resistors are available in both the E24 values and the E96 values.

[edit]Buildings

In the construction industry, it was felt that typical dimensions must be easy to use in mental arithmetic. Therefore, rather than using elements of a geometric series, a different system of preferred dimensions has evolved in this area, known as "modular coordination".

Major dimensions (e.g., grid lines on drawings, distances between wall centres or surfaces, widths of shelves and kitchen components) are multiples of 100 mm, i.e. one decimetre. This size is called the "basic module" (and represented in the standards by the letter M). Preference is given to the multiples of 300 mm (3 M) and 600 mm (6 M) of the basic module (see also "metric foot"). For larger dimensions, preference is given to multiples of the modules 12 M (= 1.2 m), 15 M (= 1.5 m), 30 M (= 3 m), and 60 M (= 6 m). For smaller dimensions, the submodular increments 50 mm or 25 mm are used. (ISO 2848, BS 6750)

Dimensions chosen this way can easily be divided by a large number of factors without ending up with millimetre fractions. For example, a multiple of 600 mm (6 M) can always be divided into 2, 3, 4, 5, 6, 8, 10, 12, 15, 20, 24, 25, 30, etc. parts, each of which is again an integral number of millimetres.

[edit]Paper documents, envelopes, and drawing pens

Main article: Paper size

Standard metric paper sizes use the square root of two and related numbers ( $\sqrt{\sqrt{2}}$ ,  $\sqrt{2}$ ,  $\sqrt{2}$ , 2, or  $2\sqrt{2}$ ) as factors between neighbour dimensions (Lichtenberg series, ISO 216). The  $\sqrt{2}$  factor also appears between the standard pen thicknesses for technical drawings (0.13, 0.18, 0.25, 0.35, 0.50, 0.70, 1.00, 1.40, and 2.00 mm). This way, the right pen size is available to continue a drawing that has been magnified to a different standard paper size.

[edit]Computer engineering

When dimensioning computer components, the powers of two are frequently used as preferred numbers:

1 2 4 8 16 32 64 128 256 512 1024 ...

Where a finer grading is needed, additional preferred numbers are obtained by multiplying a power of two with a small odd integer:

( $\times 3$ ) 6 12 24 48 96 192 384 768 1536 ...

( $\times 5$ ) 10 20 40 80 160 320 640 1280 2560 ...

( $\times 7$ ) 14 28 56 112 224 448 896 1792 3584 ...

Preferred aspect ratios

16:	15:	12:	
:8	2:1		3:2
:9	16:9	5:3	4:3
:10	8:5	3:2	
:12	4:3	5:4	1:1

In computer graphics, widths and heights of raster images are preferred to be multiples of 16, as many compression algorithms (JPEG, MPEG) divide color images into square blocks of that size. Black-and-

white JPEG images are divided into 8x8 blocks. Screen resolutions often follow the same principle. Preferred aspect ratios have also an important influence here, e.g. 2:1, 3:2, 4:3, 5:3, 5:4, 8:5, 16:9.

[edit]Retail packaging

In some countries, consumer-protection laws restrict the number of different prepackaged sizes in which certain products can be sold, in order to make it easier for consumers to compare prices.

An example of such a regulation is the European Union directive on the volume of certain prepackaged liquids (75/106/EEC [1]). It restricts the list of allowed wine-bottle sizes to 0.1, 0.25 (1/4), 0.375 (3/8), 0.5 (1/2), 0.75 (3/4), 1, 1.5, 2, 3, and 5 litres. Similar lists exist for several other types of products. They vary and often deviate significantly from any geometric series in order to accommodate traditional sizes when feasible. Adjacent package sizes in these lists differ typically by factors 2/3 or 3/4, in some cases even 1/2, 4/5, or some other ratio of two small integers.

[edit]Music

Main article: tuning system

While some instruments (trombone, theremin, etc.) can play a tone at any arbitrary frequency, other instruments (such as pianos) can only play a limited set of tones. The very popular "twelve-tone equal temperament" selects tones from the geometric sequence

where  $k$  is typically 440 Hz, though other standards have been used. However, other less common tuning systems have also been historically important as preferred audio frequencies.

Since  $2^{10} \approx 10^3$ ,  $2^{12} \approx 10^3/120 = 101/40$ , and the resultant frequency spacing is very similar to the R40 series.

[edit]Photography

In photography, aperture, exposure, and film speed generally follow powers of 2:

The aperture size controls how much light enters the camera. It's measured in f-stops: f/1.4, f/2, f/2.8, f/4, etc. Full f-stops are a square root of 2 apart. Digital cameras often subdivide these into thirds, so each f-stop is a sixth root of 2, rounded to two significant digits: 1.0, 1.1, 1.2, 1.4, 1.6, 1.8, 2.0, 2.2, 2.5, 2.8, 3.2, 3.5, 4.0.

The film speed is a measure of the film's sensitivity to light. It's expressed as ISO values such as "ISO 100". Measured film speeds are rounded to the nearest preferred number from a modified Renard series including 100, 125, 160, 200, 250, 320, 400, 500, 640, 800... This is the same as the R10' rounded Renard series, except for the use of 6.4 instead of 6.3, and for having more aggressive rounding below ISO 16. Film marketed to amateurs, however, uses a restricted series including only powers of two multiples of ISO 100: 25, 50, 100, 200, 400, 800, 1600 and 3200. Some low-end cameras can only reliably read these values from DX encoded film cartridges because they lack the extra electrical contacts that would be needed to read the complete series. Some digital cameras extend this binary series to values like 12800, 25600, etc. instead of the modified Renard values 12500, 25000, etc.

The shutter speed controls how long the camera records light. These are expressed as fractions of a second, roughly but not exactly based on powers of 2: 1 second, 1/2, 1/4, 1/8, 1/15, 1/30, 1/60, 1/125, 1/250, 1/500, 1/1000 of a second.

[edit]References

ISO 3, Preferred numbers — Series of preferred numbers. International Organization for Standardization, 1973.

ISO 17, Guide to the use of preferred numbers and of series of preferred numbers. 1973.

ISO 497, Guide to the choice of series of preferred numbers and of series containing more rounded values of preferred numbers. 1973.

ISO 2848, Building construction — Modular coordination — Principles and rules. 1984.

ISO/TR 8389, Building construction — Modular coordination — System of preferred numbers defining multimodular sizes. International Organization for Standardization, 1984.

IEC 60063, Preferred number series for resistors and capacitors. International Electrotechnical Commission, 1963

75/106/EEC [2], European Union Directive on volume of liquids. 1975.

BS 2045, Preferred numbers. British Standards Institution, 1965.

BS 2488, Schedule of preferred numbers for the resistance of resistors and the capacitance of capacitors for telecommunication equipment. 1966.

ANSI Z17.1, American National Standard for Preferred Numbers. 1973

## Lecture #7

### IT Grade (квалитет, *Standart tolerance drades*)

---

**IT Grade** refers to the International Tolerance Grade of an industrial process defined in [ISO 286](#).<sup>[1]</sup> This grade identifies what tolerances a given process can produce for a given dimension.

The specific Tolerance for a particular IT grade is calculated via the following formula.<sup>[2]</sup>

$$T = 10^{0.2 \times (ITG - 1)} \cdot (0.45 \times \sqrt[3]{D} + 0.001 \times D)$$

where:

- T is the tolerance in micrometres [ $\mu\text{m}$ ]
- D is the [geometric mean](#) dimension in millimeters [mm]
- ITG is the IT Grade, a positive integer.

One thinks of  $D$  as being the key dimension on the part and  $T$  as being the required tolerance on that key dimension. The larger the ITG, the looser the tolerance.

#### [\[edit\]](#) *Meaning and interpretation*

---

An industrial process has an IT Grade associated with, indicating how precise it is. When designing a part, an engineer will typically determine a key dimension (D) and some tolerance (T) on that dimension. Using this formula, the engineer can determine what IT Grade is necessary to produce the part with those specifications. Thus, if [injection molding](#) has an IT Grade of 13 and a part needs an IT Grade of 5, one cannot injection mold that part to those specifications. It is useful in determining the processes capable of producing parts to the needed specification.

#### [\[edit\]](#) *Alternate formulation*

---

The following [\[citation needed\]](#) has been proposed by an unsigned user, though no source is given. In "Manufacturing Processes II" (Tata McGraw-Hill Education) by H S Bawa, the following Equation is given on Page 95 for sizes over 500 mm:

$$I = 0.004 \cdot D + 2.1$$

$$T = k \cdot I$$

ITG	IT5	IT6	...	IT17	IT18
k	7	10	...	1600	2500

#### [\[edit\]](#) *See also*

---

- [Tolerances](#)
- [Manufacturing](#)
- [Interference fit](#)
- [Process capability](#)

## [\[edit\]](#) *References*

---

1. [^](#) ISO Standard 286 <http://www.webstore.ansi.org/RecordDetail.aspx?sku=ISO+286-1%3a1988>
2. [^](#) Professor Sridhar Kota: [ME 452](#) – Design for Manufacturability, course notes, [University of Michigan](#).

## [\[edit\]](#) *External links*

---

- [Engineer's Edge - IT Tolerance Grade Chart - All units shown in millimeters](#)
- [ISO Hole and Shaft tolerances/limits](#), Roymech, UK.
- [ISO Hole and Shaft Tolerances iPhone App](#), Trelleborg Sealing Solutions Germany.

## About Standards [http://www.itc.gov.hk/en/quality/psis/about\\_standards.htm](http://www.itc.gov.hk/en/quality/psis/about_standards.htm)

A standard can be as simple as a set of guidelines or a code of practice. A formal standard, approved by a recognised body, is a published document that provides rules, guidelines or characteristics for products, services, processes, production methods or management systems.

There are large number of standards to ensure the quality, compatibility and safety of products and there are many standards on service provision and business management systems.

### Why do we need Standards

Standards are found in almost every part of our life. As examples, standards help ensure that prepared food is safe for our consumption, that a light bulb fits a socket, a plug for electrical appliances fits the outlet, that buildings are safe from collapse, that we can receive consistent service from different persons at different locations of the same company. Standards can serve as a convenient means for products to meet buyers' and import requirements and serve as guidelines for a company to achieve quality management.

In short, many products and services are subject to standards :

- for health and safety reasons
- for quality assurance
- for environmental protection
- to ensure that things meant to work together actually do

A standard that has worldwide acceptance will eliminate a barrier to the free flow of international trade.

### Benefits of Standards

Standards can benefit businesses of all sizes, from multinational giants to small and medium-sized enterprises (SMEs).

Standards :

- help streamline processes to gain efficiencies, bring time and cost savings
- maximise the number of suppliers, help maintain the prices for standardised parts and materials competitive
- maximise compatibility of products, gain widespread acceptance, increase sales and market access
- enable benchmarking, for SMEs to have an easy and affordable means to benchmark their performance and compare their competitive position with that of other enterprises at national and international level
- offer a convenient and reliable means of meeting regulatory obligations
- compliance helps demonstrate competitive advantage and conveys confidence to customers
- help improve the structure of a business and organisation of work, improve the chance of success

### Voluntary vs Mandatory Standards

Most standards are voluntary, as a result of customer or industry demands. Some especially those which deal with health or safety, are mandatory and are enforced by laws or regulations as technical regulations.

### Standards vs Innovation

Standards and innovation are complementary to each other. Knowing the latest development in standards is as important as knowing the latest innovation.

Standards :

- help concentrate on developing new innovative features, save research and development cost, reduce investment risks, and enable faster time to market
- provide a stable platform for innovation, pioneering products can work seamlessly with related products, through standardisation innovation can achieve product and service differentiation
- enable interconnectivity, interoperability and interface, reduce technology complexity, help ensure exchange of information securely and productively.
- help define and measure product performance, leaving the innovator free to use a standard without divulging intellectual property
- create sufficient market and enable mass production to support new technologies



A core concept in metrology is (metrological) [traceability](#), defined as "the property of the result of a measurement or the value of a standard whereby it can be related to stated references, usually national or international standards, through an unbroken chain of comparisons, all having stated uncertainties." The level of traceability establishes the level of comparability of the measurement: whether the result of a measurement can be compared to the previous one, a measurement result a year ago, or to the result of a measurement performed anywhere else in the world.

Traceability is most often obtained by [calibration](#), establishing the relation between the indication of a measuring instrument and the value of a measurement standard. These standards are usually coordinated by national metrological institutes: [National Institute of Standards and Technology](#), [National Physical Laboratory, UK](#), [Physikalisch-Technische Bundesanstalt](#), etc.

Traceability, [accuracy](#), [precision](#), [systematic bias](#), evaluation of [measurement uncertainty](#) are critical parts of a [quality management](#) system.

## Standards

Standards are objects or ideas that are designated as being authoritative for some accepted reason. Whatever value they possess is useful for comparison to unknowns for the purpose of establishing or confirming an assigned value based on the standard. The design of this comparison process for measurements is metrology. The execution of measurement comparisons for the purpose of establishing the relationship between a standard and some other measuring device is calibration.

The ideal standard is independently reproducible without uncertainty. This is what the creators of the "meter" length standard were attempting to do in the 19th century when they defined a meter as one ten-millionth of the distance from the equator to one of the Earth's poles. Later, it was learned that the Earth's surface is an unreliable basis for a standard. The Earth is not spherical and it is constantly changing in shape. But the special alloy meter bars that were created and accepted in that time period standardized international length measurement until the 1950s. Careful calibrations allowed tolerances as small as 10 parts per million to be distributed and reproduced in metrology laboratories worldwide, regardless of whether the rest of the metric system was implemented and in spite of the shortfalls of the meter's original basis.



Historical [International Prototype Meter](#) bars

### Standard (metrology)

In [the science of measurement](#), a **standard** is an object, system, or experiment that bears a defined relationship to a unit of measurement of a physical quantity.<sup>[1]</sup> Standards are the fundamental

reference for a system of weights and measures, against which all other measuring devices are compared. Historical standards for length, volume, and mass were defined by many different authorities, which resulted in confusion and inaccuracy of measurements. Modern measurements are defined in relationship to internationally-standardized reference objects, which are used under carefully controlled laboratory conditions to define the units of length, mass, electrical potential, and other physical quantities.

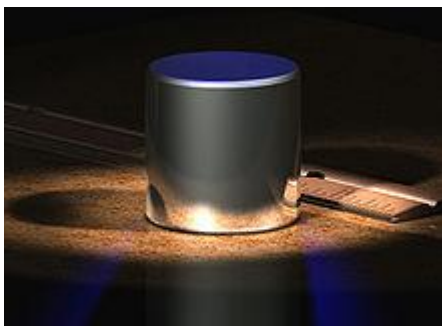

The International Prototype [kilogram](#) is an artifact standard that is defined to be exactly one kilogram mass.

Primary measurement standards may be used strictly in measurement laboratories. Less precisely controlled working standards are used for [calibration](#) of industrial measurement equipment. Primary standards that define units may be inconvenient for everyday use, so working standards represent the primary definition in a form that is easier to use. For example, the definition of the "[metre](#)" is based a laboratory experiment combining the speed of light and the duration of a second, but a machine shop will have working standard [gauge blocks](#) that are used for checking its measuring instruments.



Standard units for length would be embedded in the cornerstones of churches or important public buildings, so that all people trading in an area could agree on the units.

Initially many units of measure were defined in terms of unique artifacts which were the legal basis of units of measure. A continuing trend in metrology is to eliminate as many as possible of the artifact standards and instead define practical units of measure in terms of fundamental physical constants, as demonstrated by standardized technique. One example is the unit of electrical potential, the [volt](#). Formerly it was defined in terms of [standard cell](#) electrochemical batteries, which limited the stability and precision of the definition. Currently the volt is defined in terms of the output of a [Josephson junction](#), which bears a direct relationship to fundamental physical constants. One advantage of elimination of artifact standards is that inter-comparison of artifacts is no longer required. Another advantage would be that the loss or damage of the artifact standards would not disrupt the system of measures.

### Examples of primary reference standards

The reference standard for a [kilogram](#) is the one kilogram mass of a [platinum-iridium](#) kilogram maintained by the [Bureau International des Poids et Mesures](#) in [Sèvres](#), France.

In contrast, the reference standard for the [meter](#) is no longer defined by a physical object. In 1983, the standard meter was redefined as the [distance light travels](#) in a vacuum during  $1/299,792,458$  of a second.

### Secondary reference standards

Secondary reference standards are very close approximations of primary reference standards. For example, national measuring laboratories such as the US's [National Institute of Standards and Technology \(NIST\)](#) may house stainless steel balls of one kilogram which are used to set standards for manufacturing supermarket measuring [scales](#).

Working standards and [certified reference materials](#) used in industry have a traceable relationship to the secondary and primary standards.

### Modern standards

Currently, only five independent units of measure are internationally recognized: temperature interval, linear distance, electrical current, frequency and mass. All measurements of all types are based on one or more of these independent units. Two supplemental independent units are also recognized internationally, both dealing with angle measurement.

For example, [Ohm's law](#) is a widely known concept in electrical study. Of the three units of measure involved, only current (ampere) is an independent unit. Voltage and resistance units are dependent on current units, as defined by Ohm's law.

In the United States, ASTM Standard Practice E 380, replaced by IEEE/ASTM SI10 [\[2\]](#), adapts independent unit of measure theory to practical measurement activity.

It is believed that each of independent units of measure will be defined in terms of the other four independent units eventually. Length (meter) and time (second) are already connected this way. If an accurate time base is available, then a length standard can be reproduced without a meter bar artifact, using the known constant [speed of light](#). Lesser known is the relationship between the luminance (candela) and current (ampere). The candela is defined in terms of the watt, which in turn is derived from the ampere. This difficult to recreate standard is supplemented by an incandescent bulb design that is used as a secondary and transfer standard. These bulbs recreate the candela when a specific amount of current is applied.

The development of standards follows the needs of technology. As a result, some units of measure have much more resolution than others. The second is reproducible to 1 part in  $10^{14}$ . As it became possible to measure time more precisely, [solar time](#), believed to be a constant, proved to be very slightly irregular. This resulted in [leap second](#) adjustments to keep [UTC](#) synchronised with solar time.

Luminance (candela) can only be reproduced to 5% of reading despite having sensors that have accuracies of +/- 50 parts per million (0.005%) precision. This is due to the standard not being accurately reproducible.

Temperature (kelvin) is defined by agreed fixed points. These points are defined by the state changes of nearly pure materials, generally as they move from liquid to solid. Between these fixed points, Standard Platinum Resistance Thermometers (SPRTs), constructed in a specified manner, are used to interpolate temperature values. This mosaic of approaches produces measurement uncertainty which is not uniform over the entire range of temperature measurement. Temperature measurement is coordinated by the International Practical Temperature Scale, maintained by the BIPM.

These non-commercial measurement details used to be academic curiosities. However, engineering, manufacturing and ordinary living now routinely challenge the limits of measurement.

### **Industry-specific standards**

In addition to standards created by national and international standards organizations, many large and small industrial companies also define metrology standards and procedures to meet their particular needs for technically and economically competitive manufacturing. These standards and procedures, while drawing in part upon the national and international standards, also address the issues of what specific instrument technology will be used to measure each quantity, how often each quantity will be measured, and which definition of each quantity will be used as the basis for accomplishing the [process control](#) that their manufacturing and product specifications require. Industrial metrology standards include dynamic control plans, also known as “dimensional control plans”, or “DCPs”, for their products.

In industrial metrology, several issues beyond accuracy constrain the usability of metrology methods. These include

- The speed with which measurements can be accomplished on parts or surfaces in the process of manufacturing, which must match the [TAKT Time](#) of the production line.
- The completeness with which the manufactured part can be measured such as described in [high-definition metrology](#),
- The ability of the measurement mechanism to operate reliably in a manufacturing plant environment considering temperature, vibration, dust, and a host of other potential hostile factors,
- The ability of the measurement results, as they are presented, to be assimilated by the manufacturing operators or automation in time to effectively control the manufacturing process variables, and
- The total financial cost of measuring each part.

### **National standards**

Every country maintains its own metrology system. In the United States, the [National Institute of Standards and Technology](#) (NIST) plays the dual role of maintaining and furthering both commercial and scientific metrology. NIST does not enforce measurement accuracy directly.

The accuracy and traceability of commercial measurements is enforced per the laws of the individual states. Commercial measurement generally involves any material sold by any unit of measure. Some intuitive or obvious measurement is generally exempted, such as selling cloth on a cutting table that has

a yardstick fastened to it. All counting-based transactions are generally exempt also. But each state has its own rules, responding to the accumulated concerns of the state residents.

Commercial metrology is also known as "weights and measures" and is essential to commerce of any kind above the pure barter level. Every state maintains its own weights and measures functionality with traceability to the national standards maintained by NIST. Large states further divide this effort by county, where a "Sealer" or other appointee is responsible for the validity of most common commercial measurements such as mass balances (scales) in grocery stores and gasoline pump measurements of volume. The sealer's staff and agents make periodic inspections to catch merchant cheaters, maintaining the integrity of commercial measurements.



Typical State Seal application.

Depending on the specific state, other state government agencies can be involved. For example, electricity watt-hour meters and water delivery flow meters are commonly monitored by the state's "public utilities commission" who enforces the measurement tolerances and traceability to NIST through the utility providers. Highway State Police and the State Highway Department generally run the commercial truck weight measurement programs for safety purposes and to minimize the damage to road surfaces that overloaded trucks cause. Nearly all states license weighmasters, weighmistresses, scale calibrators and other specialists involved in commercial measuring equipment maintenance.

The term "commercial metrology" is also used to describe calibration laboratories that are not owned by the companies they serve.

Scientific metrology addresses measurement phenomena not quantified in ordinary commerce, such as the test bed pictured at the beginning of the article. Calibration laboratories that serve scientific metrology are regulated as businesses only. They may choose to have their work accredited by voluntary certification organizations based on customer desires, but there is no requirement to do so. Irresolvable disputes involving scientific metrology are generally settled in the civil court systems. Some federal government entities like the Federal Communications Commission and the Environmental Protection Administration are considered to be the final authority in their domains rather than the NIST. Disputes involving only metrology issues with those organizations probably would not be heard in any courts.

## Lecture 2

[[edit](#)]Basics

Mistakes can make measurements and counts incorrect. Even if there are no mistakes, nearly all measurements are still inexact. The term 'error' is reserved for that inexactness, also called measurement uncertainty. Among the few exact measurements are:

- The absence of the quantity being measured, such as a [voltmeter](#) with its leads shorted together: the meter should read zero exactly.
- Measurement of an accepted constant under qualifying conditions, such as the [triple point](#) of pure water: the [thermometer](#) should read 273.16 [kelvin](#) (0.01 degrees Celsius, 32.018 degrees Fahrenheit) when qualified equipment is used correctly.
- Self-checking ratio metric measurements, such as a [potentiometer](#): the ratio in between steps is independently adjusted and verified to be beyond influential inexactness.

All other measurements either have to be checked to be sufficiently correct or left to chance. Metrology is the science that establishes the correctness of specific measurement situations. This is done by anticipating and allowing for both mistakes and error. The precise distinction between measurement error and mistakes is not settled and varies by country. [Repeatability](#) and [reproducibility](#) studies help quantify the precision: one common method is an [ANOVA gauge R&R](#) study.

[Calibration](#) is the process where metrology is applied to measurement equipment and processes to ensure conformity with a known [standard](#) of measurement, usually traceable to a national standards board.