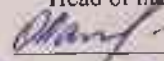

MINISTRY OF EDUCATION AND SCIENCE OF UKRAINE
NATIONAL AVIATION UNIVERSITY
FACULTY OF ARCHITECTURE, CIVIL ENGINEERING AND DESIGN
COMPUTER TECHNOLOGIES OF AIRPORT CONSTRUCTION AND
RECONSTRUCTION DEPARTMENT

TO ADMIT TO GUARD

Head of the Department

O.I. Lapenko
- 4 - 100 2022

BACHELOR THESIS

(EXPLANATORY NOTE)

SPECIALTY 192 «BUILDING AND CIVIL ENGINEERING»

Educational and professional program: «Industrial and civil engineering»

Theme: Low rise office center in Okhtyrka city of Sumy region

Performed by: _____ Peter Nan Perto

Thesis Advisor: _____ Hasii Hryhorii

Design rule check:  _____ O. Rodchenko

Kyiv 2022

МІНІСТЕРСТВО ОСВІТИ І НАУКИ УКРАЇНИ
НАЦІОНАЛЬНИЙ АвіАЦІЙНИЙ УНІВЕРСИТЕТ
ФАКУЛЬТЕТ АРХІТЕКТУРИ, БУДІВНИЦТВА ТА ДИЗАЙНУ
КАФЕДРА КОМП'ЮТЕРНИХ ТЕХНОЛОГІЙ БУДІВНИЦТВА ТА
РЕКОНСТРУКЦІЇ АЕРОПОРТІВ

ДОПУСТИТИ ДО ЗАХИСТУ

Завідувач випускової кафедри

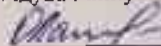
 О.І. Лашченко

“ 4 ” / 06 2022 р.

ДИПЛОМНА РОБОТА

(ПОЯСНЮВАЛЬНА ЗАПИСКА)

ВИПУСКНИКА ОСВІТНЬОГО СТУПЕНЯ БАКАЛАВРА
ЗА СПЕЦІАЛЬНІСТЮ 192 «БУДІВНИЦТВО ТА ЦИВІЛЬНА ІНЖЕНЕРІЯ»
ОСВІТНЬО-ПРОФЕСІЙНА ПРОГРАМА
«ІПРОМИСЛОВЕ І ЦИВІЛЬНЕ БУДІВНИЦТВО»

Тема: «Малоповерховий офісний центр у м. Охтирка Сумської області»

Виконавець: студент ЦБ-406 Ба гр. НАН Петер Нан Перто

(студент, група, прізвище, ім'я, по батькові)

Керівник: д.т.н., доцент Гасій Григорій Михайлович

(науковий ступінь, місце звання, прізвище, ім'я, по батькові)

Нормоконтролер:



Родченко О.В.

(ПІБ)

Київ 2022

НАЦІОНАЛЬНИЙ АВІАЦІЙНИЙ УНІВЕРСИТЕТ

Факультет архітектури, будівництва та дизайну

Кафедра комп'ютерних технологій будівництва та реконструкції аеропортів

Спеціальність: 192 «Будівництво та цивільна інженерія»

Освітньо-професійна програма: «Промислове і цивільне будівництво»

ЗАТВЕРДЖУЮ

Завідувач кафедри

 О.І. Лапенко

« 13 » 04 2022 р.

ЗАВДАННЯ

на виконання дипломної роботи

НАН Петер Нан Перго

(ІІІБ, випускника)

1. Тема роботи «Малоповерховий офісний центр у м. Охтирка Сумської області»

затверджена наказом ректора від «13» квітня 2022р. № 379/ст.

2. Термін виконання роботи: з «23» травня 2022р. по «19» червня 2022р.

3. Вихідні дані роботи: малоповерховий офісний центр, навантаження відповідно до ДБН В.1.2-2:2006 «Навантаження та впливи».

4. Зміст пояснювальної записки:

Вступ, аналітичний огляд, архітектурно-планувальна частина, розрахунково-конструктивна частина, технологічно-організаційна частина, висновки, список використаних джерел.

5. Перелік обов'язкового ілюстративного матеріалу: таблиці, рисунки, діаграми, графіки не менше 4-х креслень та 4-х слайдів:

- фасади, план типового поверху, експлікації

- креслення конструкції, специфікації елементів

- технологічно-організаційні схеми виконання основних будівельних процесів

6. Календарний план-графік

№ з/п	Завдання	Термін виконання	Підпис керівника
1.	Аналітичний огляд	13.05.22-14.05.22	Гасій
2.	Архітектурно-будівельний розділ	16.05.22-20.05.22	Гасій
3.	Розрахунково-конструктивний розділ	23.05.22-02.06.22	Гасій
4.	Технологічно-організаційна частина	03.06.22-04.06.22	Гасій
5.	Вступ. Висновки. Список використаних джерел.	06.06.22-07.06.22	Гасій
6.	Підготовка доповіді та презентації	08.06.22-11.06.22	Гасій

8. Дата видачі завдання: «13» травня 2022 р.

Керівник дипломної роботи:

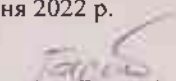

Гасій Г.М.

Завдання прийняв до виконання:



НАН Петер Нан Перто

Content

INTRODUCTION _____	1
CHAPTER 1. Analytical review _____	4
1.1 Traditional Office Space _____	8
1.2 Creative Office Space _____	8
1.3 Contiguous Office Space _____	9
1.4 Coworking Space _____	9
1.5 Executive Suites Space _____	9
CHAPTER 2. Architectural part _____	11
2.1 General data _____	11
2.2 Natural conditions _____	11
2.3 Space and planning decision of the building _____	12
2.4 Architectural and constructive decisions _____	13
2.5 Master plan _____	14
2.5.1 Master Ground floor plan _____	14
2.5.2 Master first floor plan _____	15
2.6 Room list _____	16
2.7 Ground floor plan _____	17
2.8 First floor plan _____	18

2.9 Facades	19
2.10 Elevation 3D design	20
CHAPTER 3.Structural part	21
3.1 Building plan	21
3.2 General data	22
3.2.1 Loads	22
3.2.2 Material properties	22
3.3 Design of structural elements	22
3.3.1 Design of slabs	22
3.3.2 Design of beams	24
3.3.3 Design of columns	28
3.4 Structural plans	33
3.4.1 Slab reinforcement	33
3.4.2 Columns and axes	37
3.4.3 Foundation	40
CHAPTER 4.Technology of construction	43
4.1 Types of pumps	45
4.1.1 Boom pumps	45
4.1.2 Line pumps	45

Conclusions _____ 47

References _____ 48

INTRODUCTION

The office building is a very tangible reflection of a profound change in employment patterns that occurred over the last one hundred years. In the U.S., northern Europe, and Japan, at least 50 percent of the working population is employed in office settings as compared to 5 percent of the population at the beginning of the 20th century. However, today's office buildings are experiencing even more change due to the recent pandemic. The office is now a place for collaboration, talent recruitment, onboarding, and inspiration with new requirements and expectations that combine physical spaces with technologically supported ways to work, in the office or remotely.

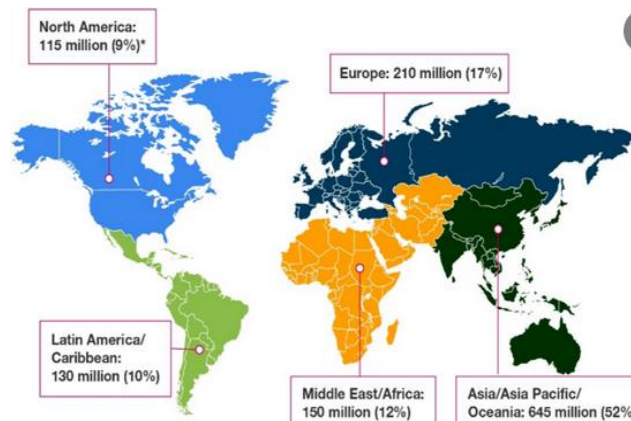

Figure 1 Position of the building

Typically, the life-cycle cost distribution for a typical service organization is about 3 to 4 percent for the facility, 4 percent for operations, 1 percent for furniture, and 90 to 91 percent for salaries. As such, if the office structure can leverage the 3 to 4 percent expenditure on facilities to improve the productivity of the workplace, it can have a very dramatic effect on personnel contributions representing 90 to 91 percent of the service organization's costs.

To accomplish this objective, the office building must benefit from an integrated design approach that focuses on meeting a list of design objectives. Through integrated design, high-performance office buildings offers owners and users increased worker satisfaction and productivity, improved health, greater flexibility, and enhanced energy and environmental performance. Typically, these projects apply life-cycle analysis to optimize initial investments in architectural design, systems selection, and building construction.



Figure 2 Office design

So, it's important to take in consideration making a right atmosphere for workers as it's an important part of office design. A well-designed office and the tone it communicates can impact the team's efficiency, productivity, morale, and overall attitude. That same well-designed office also communicates volumes about the business to clients and customers.

Each company culture differs from the other. An effective office design will recognize and celebrate these distinctive differences in a manner.

These defining characteristics give each business it's personality and help attract and retain clients, vendors, partners, and top talent. An office design that reinforces the company culture can even amplify team spirit within the business.

An effectively designed work environment enables staff to work more efficiently and the employer to attract and retain qualified staff. Leveraging the workplace environment leads to increased productivity, motivation, creativity, and efficiency.

Design standards are the foundation of office space accommodation planning, and they assist the employer to provide a suitable work environment that is based on an equal distribution of resources.

The corporate application of space standards is the primary way in which consistent office workplace densities are achieved. Without equal application of the standards throughout the organization, density targets.

CHAPTER 1. ANALYTICAL REVIEW

The design standards recognize that work office buildings do have different functions than nearby residential structures, When considering the office space needed, analysis should be carried out of the types of spaces required, the number of different areas, i.e. open office spaces, enclosed cubicles, private meeting facilities, conference areas etc, the number of employees (current and anticipated), recreational requirements, welfare facilities, The office buildings of cities and towns is made up of a wide variety usage, so depending on the size and degree to which its design process should take its direction.

To reach convenient place to work at we should follow some important requirements as:

Every room where persons work shall have sufficient floor area, height and unoccupied space for purposes of health, safety and welfare.

Workrooms should have enough free space to allow people to get to and from workstations and to move within the room, with ease. The number of people who may work in any particular room at any one time will depend not only on the size of the room, but on the space taken up by furniture, fittings, equipment, and on the layout of the room. Workrooms, except those where people only work for short periods, should be of sufficient height (from floor to ceiling) over most of the room to enable safe access to workstations. In older buildings with obstructions such as low beams the obstruction should be clearly marked.in this case, knowledge of a variety of structural systems and solutions plays an important role, each of which has its own way of responding to the requirements of a design problem. In designing, the engineer should be familiar with and make skillful use of structural systems and systems of stability of the framework and its elements, materials of the supporting and enveloping structures, Construction and assembly methods, technical solutions engineering solutions, etc.

The economic performance of a building is greatly influenced not only by the shape of the typical floor plan, but also by its floor area. This is especially true for buildings with reinforced concrete frames; the most common design solution in modern low-rise office buildings. Continuous development of concrete and reinforced concrete products is accompanied by a corresponding improvement in the aesthetic qualities of the structures, which largely solves the problem of costly and multifaceted finishing of buildings and facades. A high level of precision and dimensional accuracy is achieved through the use of new construction methods.

Concrete as a construction material has the following advantages:

- Concrete is economical compared to other engineering materials
- Concrete possesses a high compressive strength, and weathering effects are minimal when properly prepared.
- It is strong in compression and has unlimited structural applications in combination with steel reinforcement because concrete and steel have approximately equal coefficients of thermal expansion
- It is durable, fire resistant, and requires very little maintenance
- Concrete can be pumped hence it can be laid in difficult positions.

The continuous development of concrete and reinforced concrete products is accompanied by a corresponding improvement in the aesthetic qualities of the structures, which largely solves the problem of costly and multifaceted finishing of buildings and facades. A high level of precision and dimensional accuracy is achieved through the use of new construction method.

These advantages have resulted in extensive use of concrete in the construction of buildings, skyscrapers, tunnels and water retaining structures.

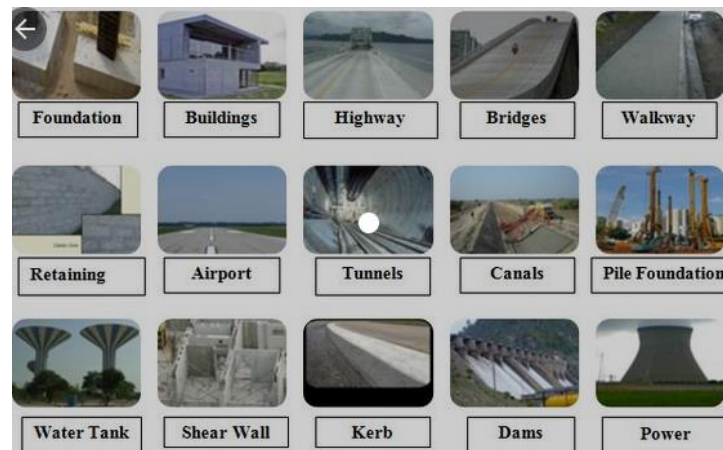

Figure 1.1 Concrete structures

There are a lot of structural systems using concrete, the choice of the most convenient structural system depends on some factors.

Recent advancements in various structural systems have made the selection of the appropriate structural system for a specific project a challenging decision making process. This process involves different economic and technical criteria representing the availability of experienced technicians and engineers and necessary machinery and construction materials. Economic life cycle, design loads, environmental protection related issues, safety of the project site, and vulnerability to natural disasters such as earthquakes are also issues related to the country and location in which the project will be constructed and they should also be addressed in the decision making process, selection of structural systems is characterized by several features, interactive procedure, requiring a great deal of co-ordination of information from various sources. The selection of structural system is an initial task in the overall process of the structural design, where the result is a proposed general arrangement of the structure, incorporating the overall form, geometry and nomination of the principal structural elements.

In this thesis there are some factors affecting our choice and the most suitable structural system is concrete solid slabs rested on concrete beams, transferring the load from beams to columns and from columns to concrete isolated foundations. Solid slabs are used as floor elements in residential, social and commercial construction which require a slab with a high level of loading, high fire resistance and good acoustic and thermal insulation.

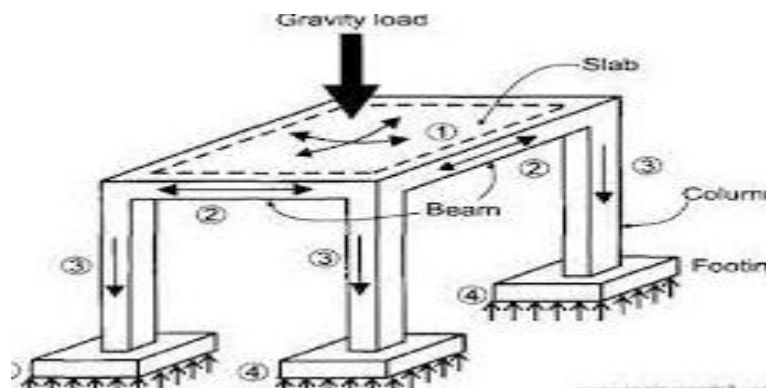

Figure 1.2 Transfer of loads

This system consists of beams framing into columns and supporting slabs spanning between the beams. It is a very traditional system with some advantages as

- The relatively deep beams provide a stiff floor capable of long spans
- Able to resist lateral loads due to the framing action
- It is economic for small to medium spans.
- It is suitable for heavy loads or dynamic load.
- It is easy to repair or strengthen.
- It is good to hide services such electrical and mechanical pipe

In reinforced concrete structures there is less slab thickness, resulting in lower

Building heights, less exterior wall area, and less stairway elevation. Columns and beams made of reinforced concrete need no further treatment, whereas steel structures need to be covered and require fire protection.

Due to the obvious advantages of reinforced concrete structures it is advisable to spread them widely. to achieve this, the low rise office building should be designed so that it is as close as possible to modern concrete structures and the technology in use.

The following characteristics should be considered as a basis for the classification of office buildings: purpose; number of stories; duration of occupancy; number of offices ; layout structure; architectural and spatial structure; settlement type; urban situation; comfort level; availability of occupation.

Also the type of the office work as there are some different design spaces types as:

1.1 Traditional Office Space

The most basic type of office layout is the – traditional office space. This type of space is most suitable for businesses offering financial services, such as hedge funds, banks, or law firms. This is mainly because the classic layout of this office provides employees with peace, quiet and private areas where they can focus on their work. A traditional office space typically entails a reception, bullpen, boardroom, and private offices.

1.2 Creative Office Space

Another type of office space that is becoming popular by the day is a creative office space. A creative space layout is meant to encourage and enhance teamwork and collaboration. Generally, you will notice that many start-up firms, advertising agencies, and creative agencies focus on adopting this type of layout. This office space typically entails a few barriers and are often, highly transparent. Moreover,

creative spaces are tailored to be more space-efficient and usually have an open-plan layout. These spaces focus on having more tables for their employees rather than cubicles. Even though creative office spaces differ in style, color, themes, etc, however, there are a few common traits that they all share. For instance, creative office spaces usually have wooden floors, large windows, high ceilings, fewer walls and wet pantries.

1.3 Contiguous Office Space

A contiguous office space entails multiple suites that are combined on the same floor of a building. This entire floor is mostly rented out to a single tenant. For instance, a business could lease more than one floor in a building according to their requirement. A contiguous office space is typically leased by large businesses that require multiple workplaces or offices for the different departments of their business.

1.4 Coworking Space

Another office space that has seen to gain popularity over time is the co-working space. This type of office space aims to offer flexibility to small businesses that are commencing their operations or are at their initial stage. Start-ups and small companies that require a workspace can rent a number of desks as per their need. A co-working space includes break and meeting rooms. Moreover, these spaces also have shared amenities appliances. The purpose of leasing a co-working space is to encourage collaboration and communication while keeping costs super-low.

1.5 Executive Suites

An executive suite is as classy and as good as an office space can get! It is basically a fully serviced and furnished office space meant for lucrative businesses. The lease of an executive suite is pretty lenient as you can either get a monthly, quarterly, bi-annually, or yearly sublet. Moreover, an executive suite is already pre-wired for

internet and phone services. If you're not sure which one of the different types of office spaces is best for your company, you don't need to worry. You can simply start by analyzing your company's size, budget, culture, and growth plans in the future.

In this thesis we have chosen the traditional office space, The composition of spaces in ground floor is : office rooms ,meeting room, kitchen, cafeteria, manager office, storage, reception and toilets.

And in first floor is: office rooms, secretary room, kitchen, cafeteria, vip room, storage and toilets. Also there are atriums with green areas to provide good view for workers.

Therefore the design engineer should be aware of the standards of design of work office buildings and taking into account the requirements for specific conditions.

In this office building we used as much as possible the space existed to provide required services in a working place.

CHAPTER 2. Architectural part

2.1 General data

The proposed office Centre will accommodate around 50 workers in two floors. This project design report is aimed to provide a concise package of information illustrating the analysis of existing conditions, the planning and design, the evaluation of options and finally the recommended concept design approach to the development of the project. This report function as a tool to communicate the development of the concept design.

The process of developing the concept design was broken into some steps:

- The first step taken was the inception of the existing buildings and conditions helped to choose a concept design.
- The second step was taken to provide architectural drawings of existing building blocks with all programs.
- The third step was taken to maintain specific needs and requirements of the building.
- The fourth step was to develop the approved concept.

2.2 Natural conditions

The project is located in Okhtyrka City of Sumy region, its Located south of the Sumy region, it lies in the center of a triangle created by regional centers – Sumy, Kharkiv and Poltava. The city is on the left bank of the Vorskla River, called the blue pearl of Ukrainian rivers. the site covers approximately (665 m²) in total and is located to the junction of two roads which is opportunity to have a good visual and physical interaction with green access and embellishment.

Normally the site provides vibrant views from all sides also it is easy access to some services.

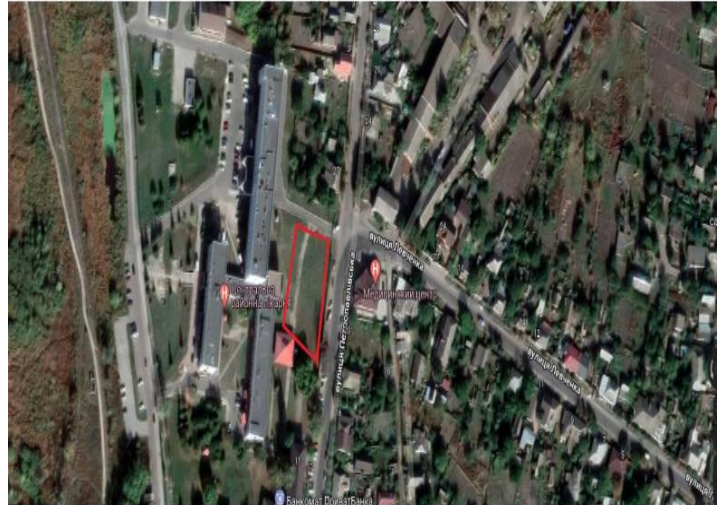

Figure 2.1 Site location

2.3 Space and planning decision of the building

We need to develop our plot with a design that is flexible and technologically-advanced working environments that are safe, healthy, comfortable, durable, aesthetically-pleasing, sustainable, and accessible.

Also our design maintain privacy for each office to develop the right environment for each worker, and it provides safety as it contains extra stairs for any emergency, enclosed cubicles, private meeting facilities, conference areas.

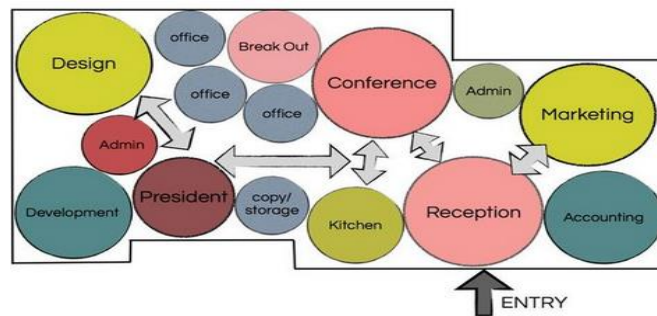

Figure 2.2 Bubble diagram

2.4 Architectural and constructive decisions

The two stories Ground floor and First floor consists of reinforced concrete framed structure solid slab system.

As it is the suitable system for small areas also it's the best system to resist lateral loads due to the framing action.

And we can provide low cost by this system because it needs low amount of steel.

Masonry block waling and partitions,

- Ceramic tiles to common areas and staircases.
- Non-slip ceramic floor tiles to all wet areas.
- Ceramic tiles to toilet's walls.
- Plaster ceiling finish.
- Aluminum casement windows.
- Aluminum casement doors externally, and timber panel internally, steel casement emergency exit doors.

2.5 Master plan

2.5.1 Master Ground floor plan

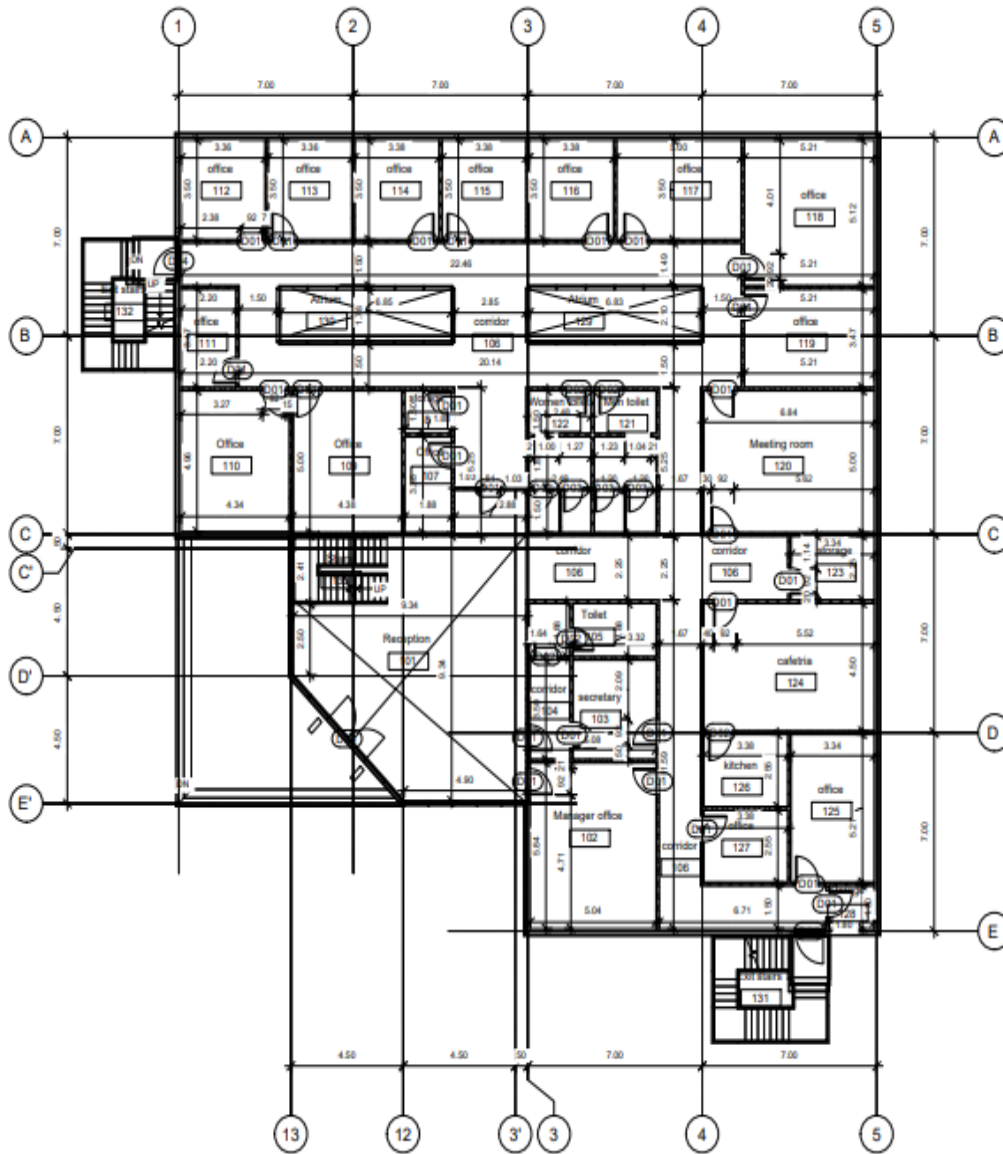

2.5.2 Master first floor plan

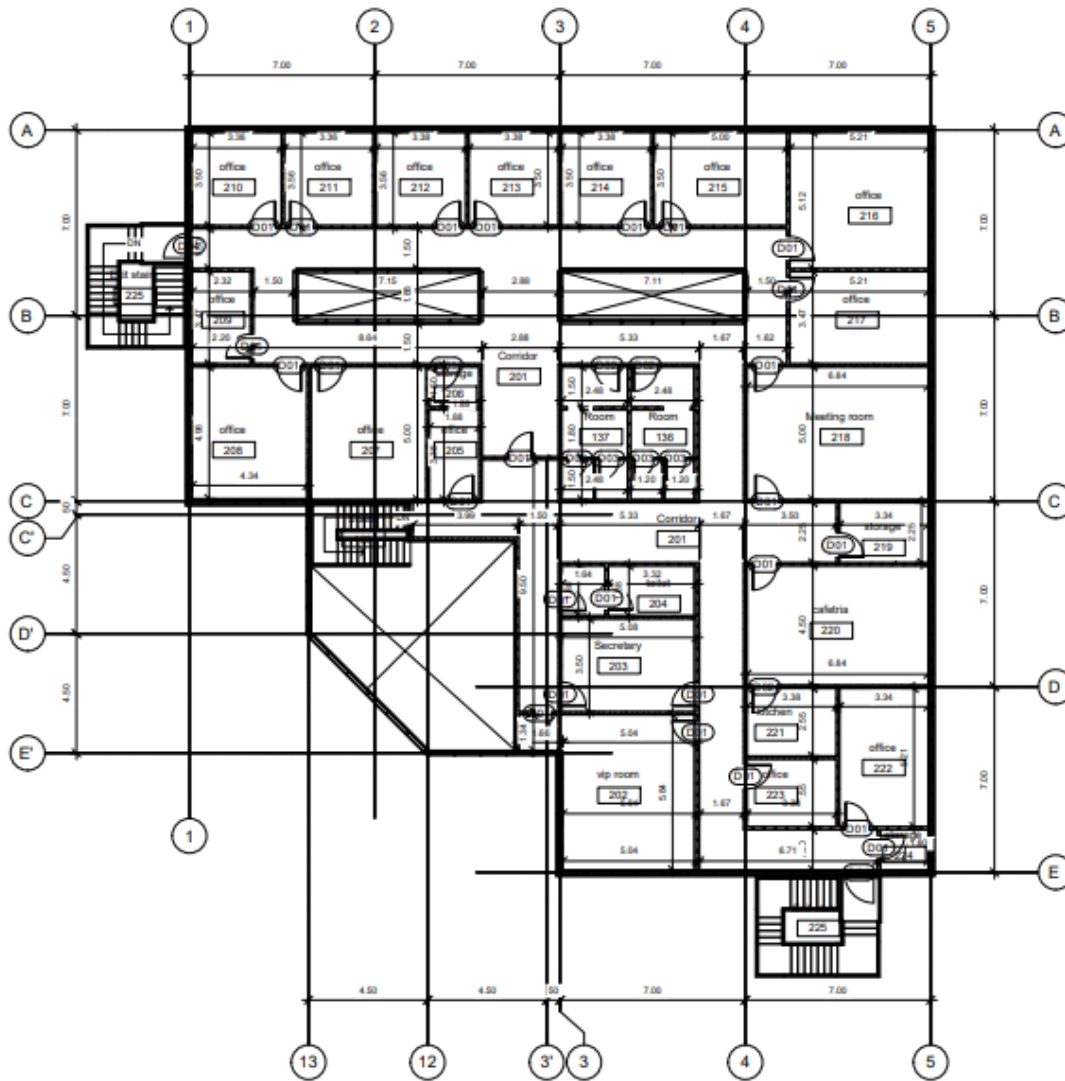

2.6 Room list



2.7 Ground floor plan

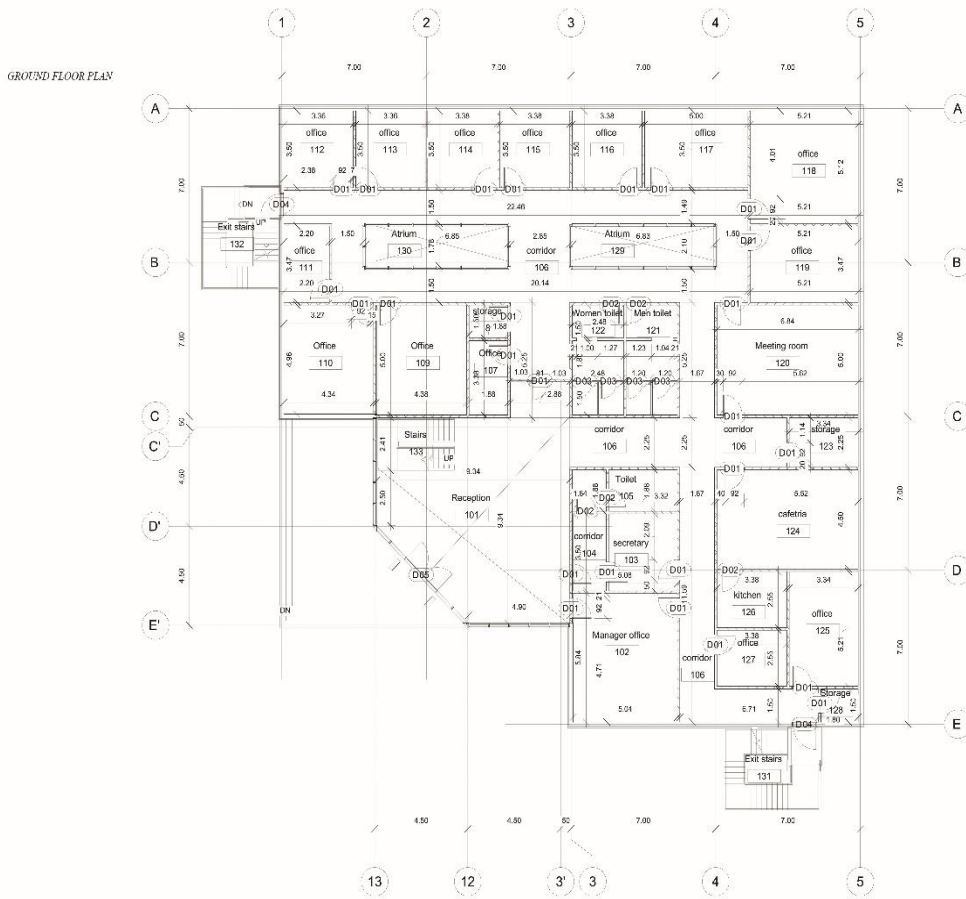

2.9 Facades

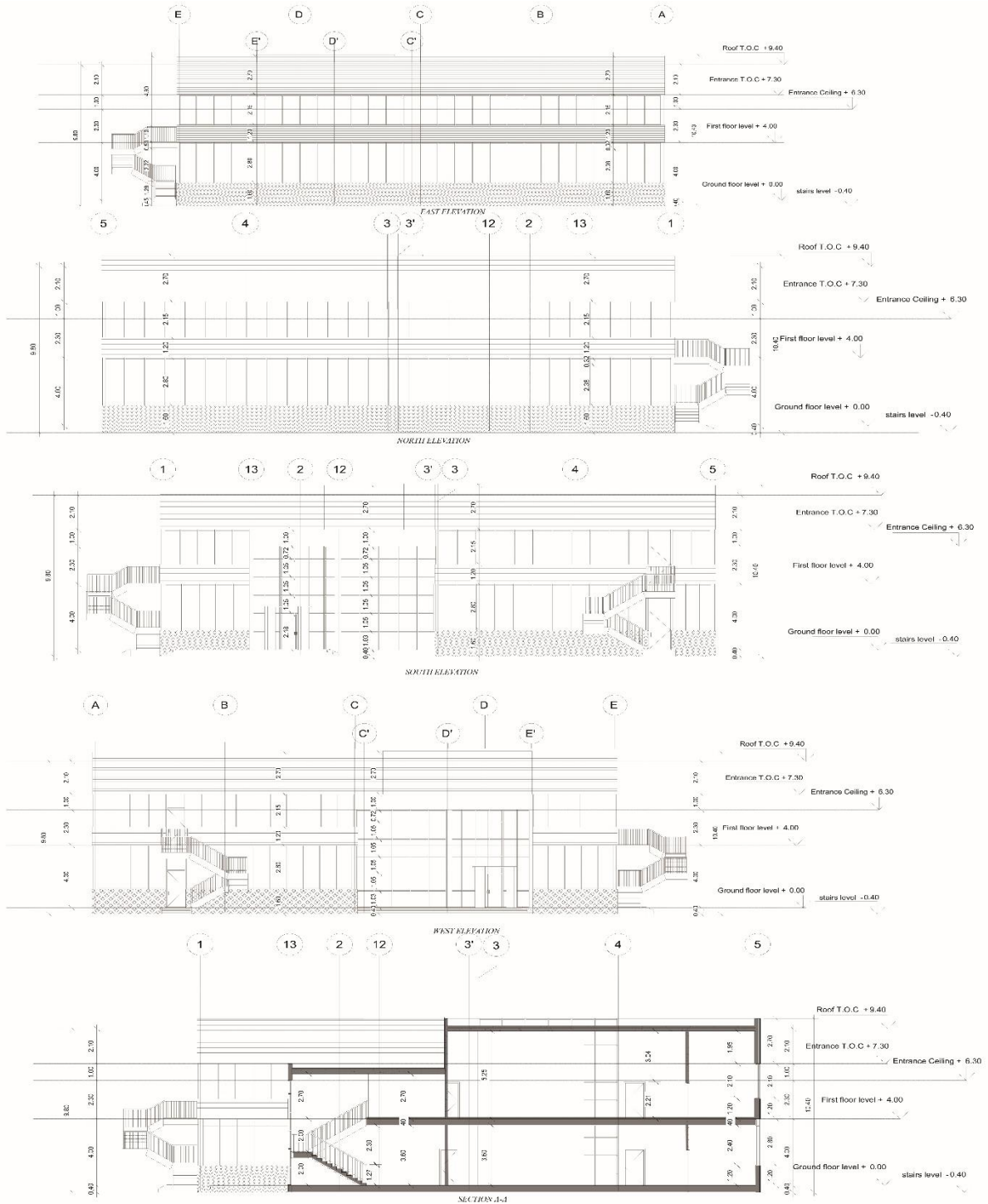

2.10 Elevation 3D design

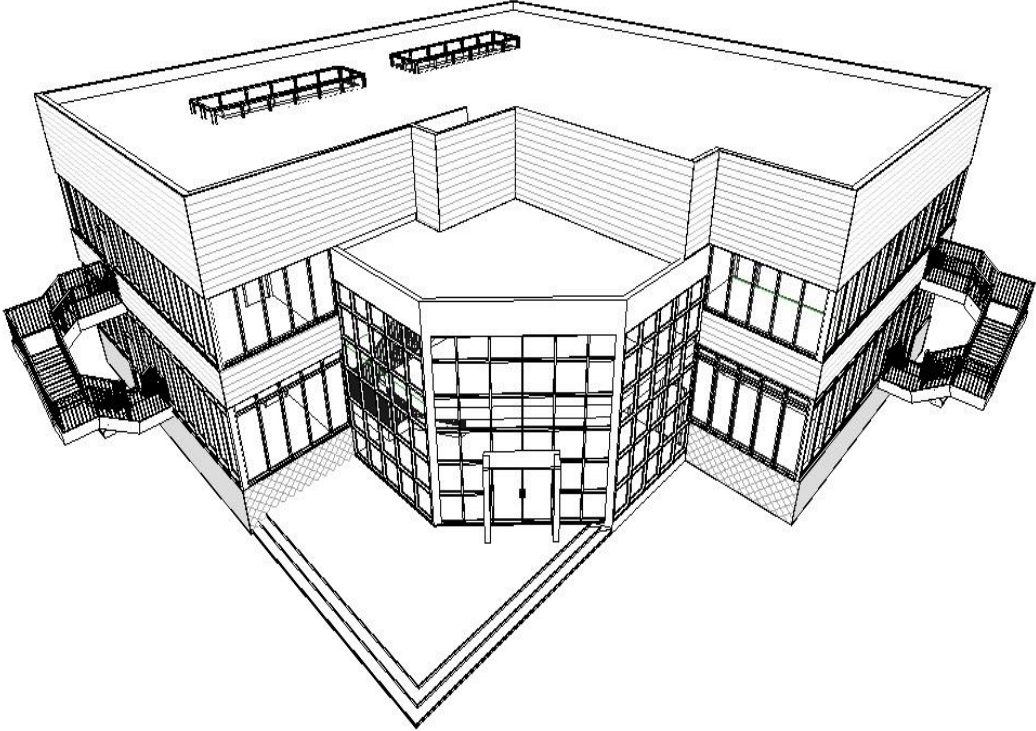

CHAPTER 3. Structural part

3.1 Building plan

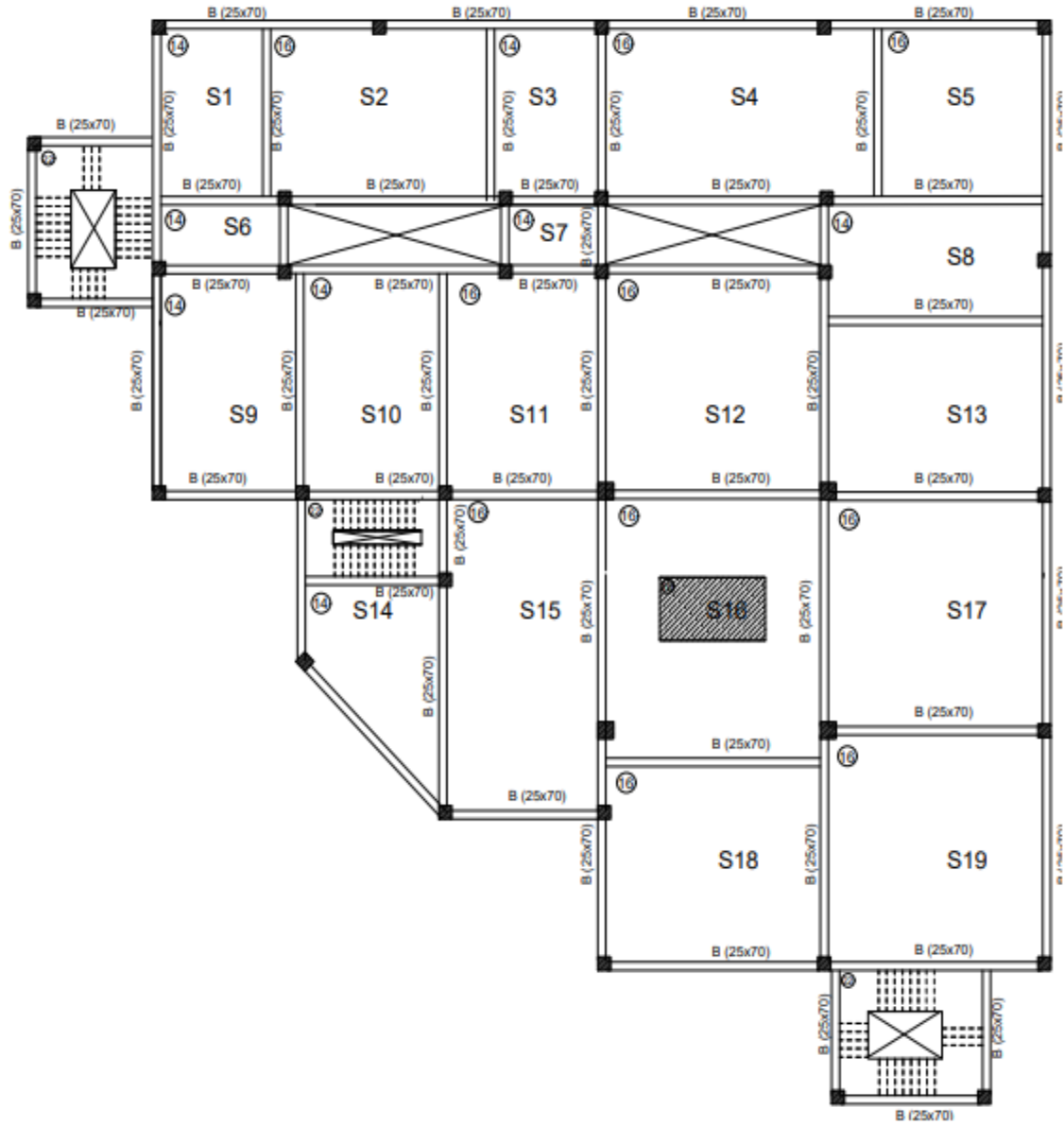

Figure 3.1 Structural plan

3.2 General data

3.2.1 Loads

- Live load= 0.3 ton/m²
- Floor cover=0.25 ton/m²
- Walls=0.25 ton/m²

3.2.2 Material properties

- Concrete for slabs, beams and foundation, $F_{cu} = 250 \text{ kg/cm}^2$
- Concrete for columns, $F_{cu} = 300 \text{ kg/cm}^2$
- Allowable bearing capacity of soil = 1.5 kg/cm^2
- Steel used is 36/52, $f_y = 36000 \text{ kg/cm}^2$, $f_u = 52000 \text{ kg/cm}^2$
- Mild steel used is 24/35, $f_y = 24000 \text{ kg/cm}^2$, $f_u = 35000 \text{ kg/cm}^2$
- Building height=9.4 meters

3.3 Design of structural elements

3.3.1 Design of slabs

- Largest slab is S16 with clear area $(7.7 \times 6.7) \text{ m}^2$
- Thickness of the slab= $6.7/45 = 0.16 \text{ m}$
- $W_s = 1.4 (t_s \times \text{gamma concrete} + \text{floor cover}) + 1.6 (\text{Live load}) = 1.4 (0.16 \times 2.5 + 0.25) + 1.6 (0.3) = 1.39 \text{ ton/m}^2$
- $R = 0.76 \times 7.6 / 0.76 \times 6.7 = 1.14$, $\text{Alpha} = 0.422$ / $\text{Beta} = 0.267$

By solving the slab with 3 moment equation

- Moment in X-direction= 2.7 m.ton
- Moment in Y-direction = 2 m.ton
- Concrete cover for slab =20 mm
- $D = t - \text{cover} = 160 - 20 = 140 \text{ mm}$

Reinforcement in X-direction

- $D = c1 \sqrt{\text{Moment} / F_{cu} * b}$, $c1 = 5$ $j = 0.826$
- $\text{Area of steel} = \frac{\text{moment}}{j * f_{yield} * d} = \frac{27 * 10^6}{0.826 * 360 * 140} = 650 \text{ mm}^2/\text{m}$
- 8 phi 12/m

Reinforcement in Y-direction

- $\text{Area of steel} = \frac{\text{moment}}{j * f_{yield} * d} = \frac{20 * 10^6}{0.826 * 360 * 140} = 480 \text{ mm}^2/\text{m}$
- 8 phi 10/m

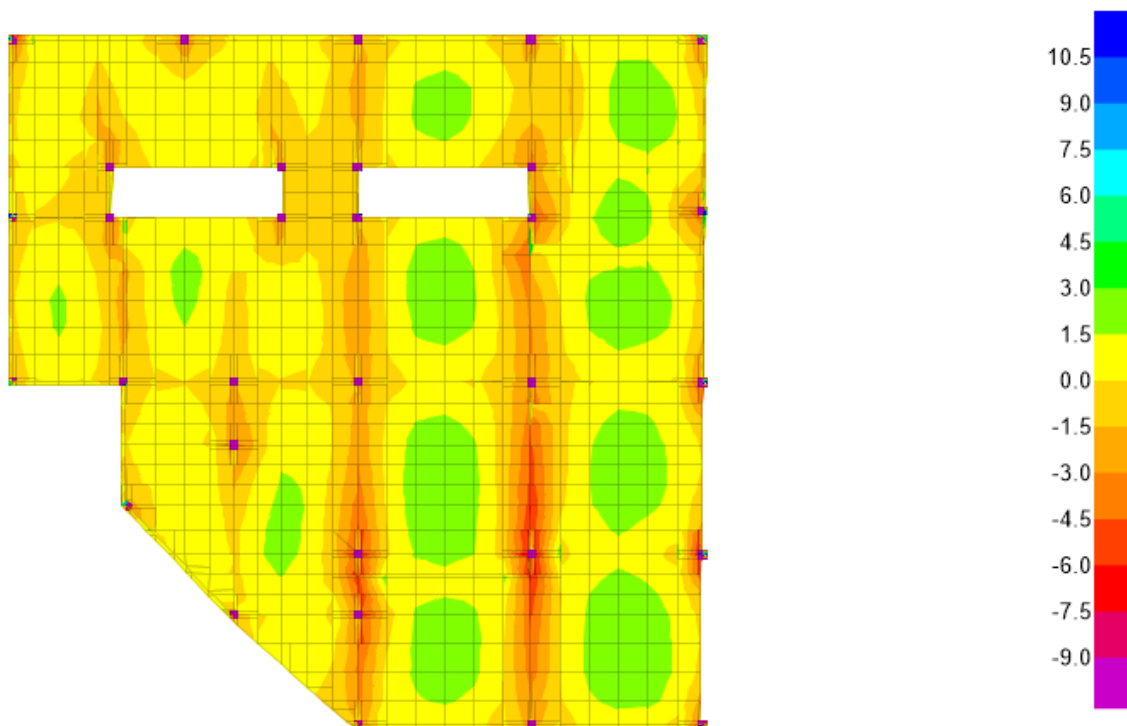

Figure 3.2 Moment of slab in X-direction

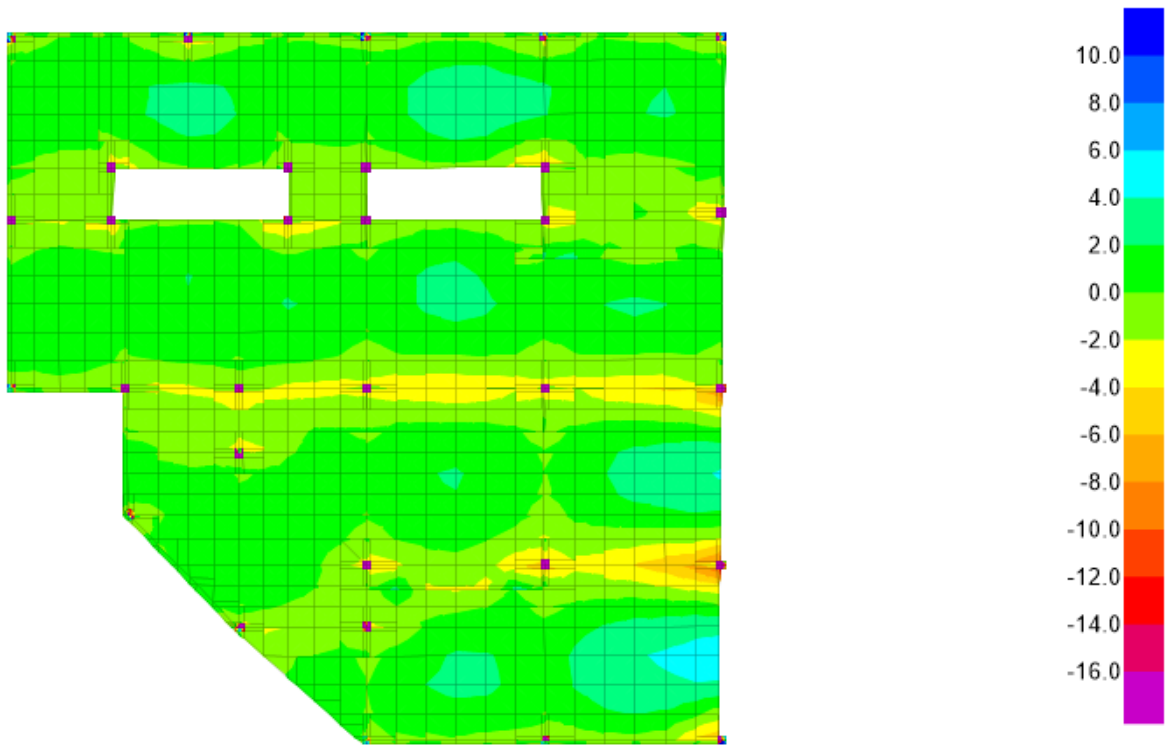

Figure 3.3 Moment of slab in Y-direction

3.3.2 Design of beams:

- Dimensions of beams assumed to be 25x70 cm
- Own weight of beams= $0.25 \times 0.7 \times 2.5 = 0.5$ t/m
- Weight of walls= $0.25 \times (3.5 - 0.16) \times 1.8 = 1.5$ t/m

We will get the load applied from the slab on beams by dividing angles between beams as following

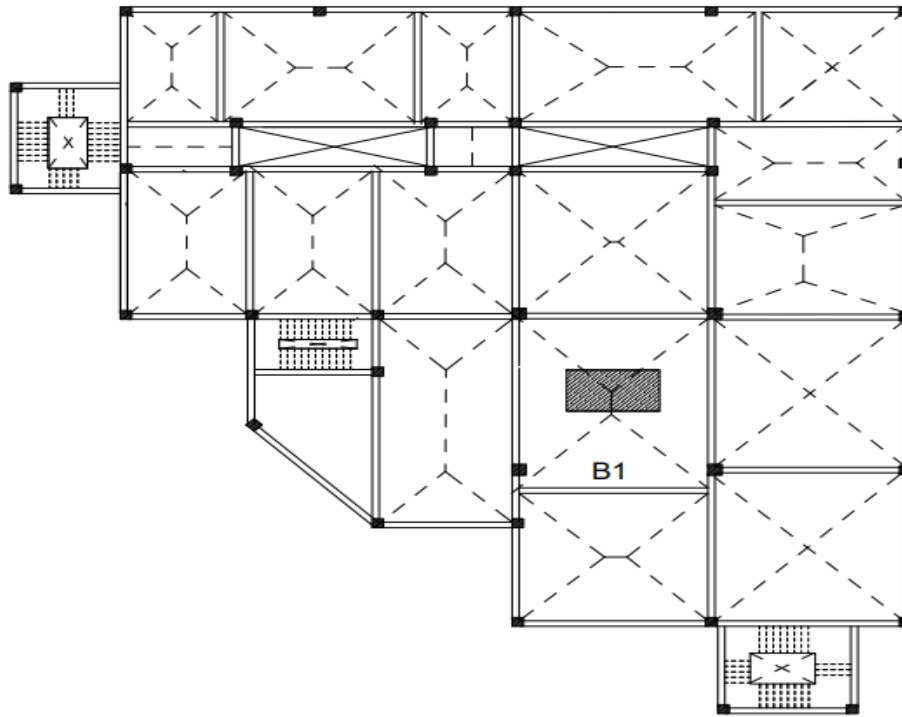

Figure 3.4 Load distribution on beams

- Load on B1= own weight + $c_e * L_{short} * \frac{w \text{ from slab}}{2}$
- $C_e \text{ for trapezoid} = 1 - \frac{1}{3} \left(\frac{6.75}{7.6} \right)^2 = 0.7$
- $C_e \text{ for triangle} = \frac{2}{3}$
- $B1 = 0.5 + 0.7 * 1.4 * 2.9 + \frac{2}{3} * 1.4 * 3.3 = 6.4 \text{ t/m}$
- Assume $c_1 = 3.5$, $j = 0.826$
- $\text{Moment} = \frac{W * l^2}{8} = 36.45 \text{ m.t}$
- $\text{Area of steel} = \frac{\text{moment}}{j * f_{yield} * d} = 1885 \text{ mm}^2$

- Check minimum area of steel = $(0.225 * \frac{\sqrt{f_{cu}}}{f_{yield}})bd = 507 \text{ mm}^2$
- Area steel required is larger than area steel minimum, so we will use area steel required $1885 \text{ mm}^2 = 10 \text{ phi } 16$

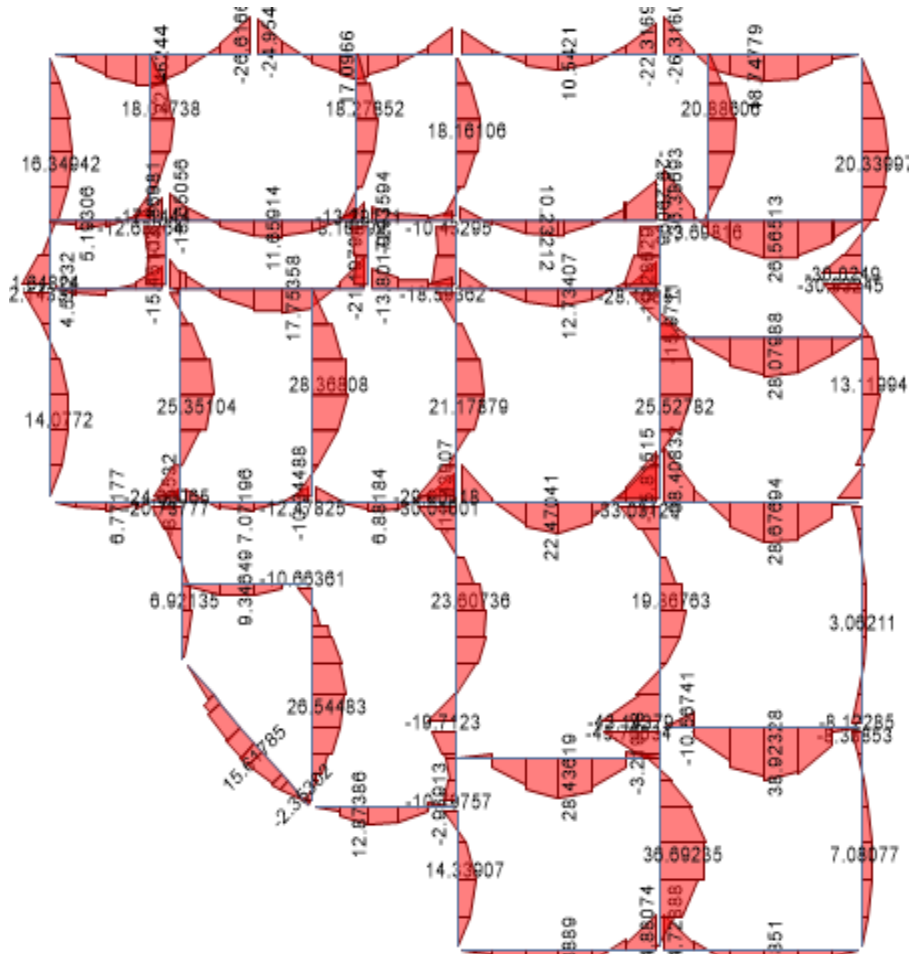

Figure 3.5 Moment on beams

3.3.3 Design of Columns:

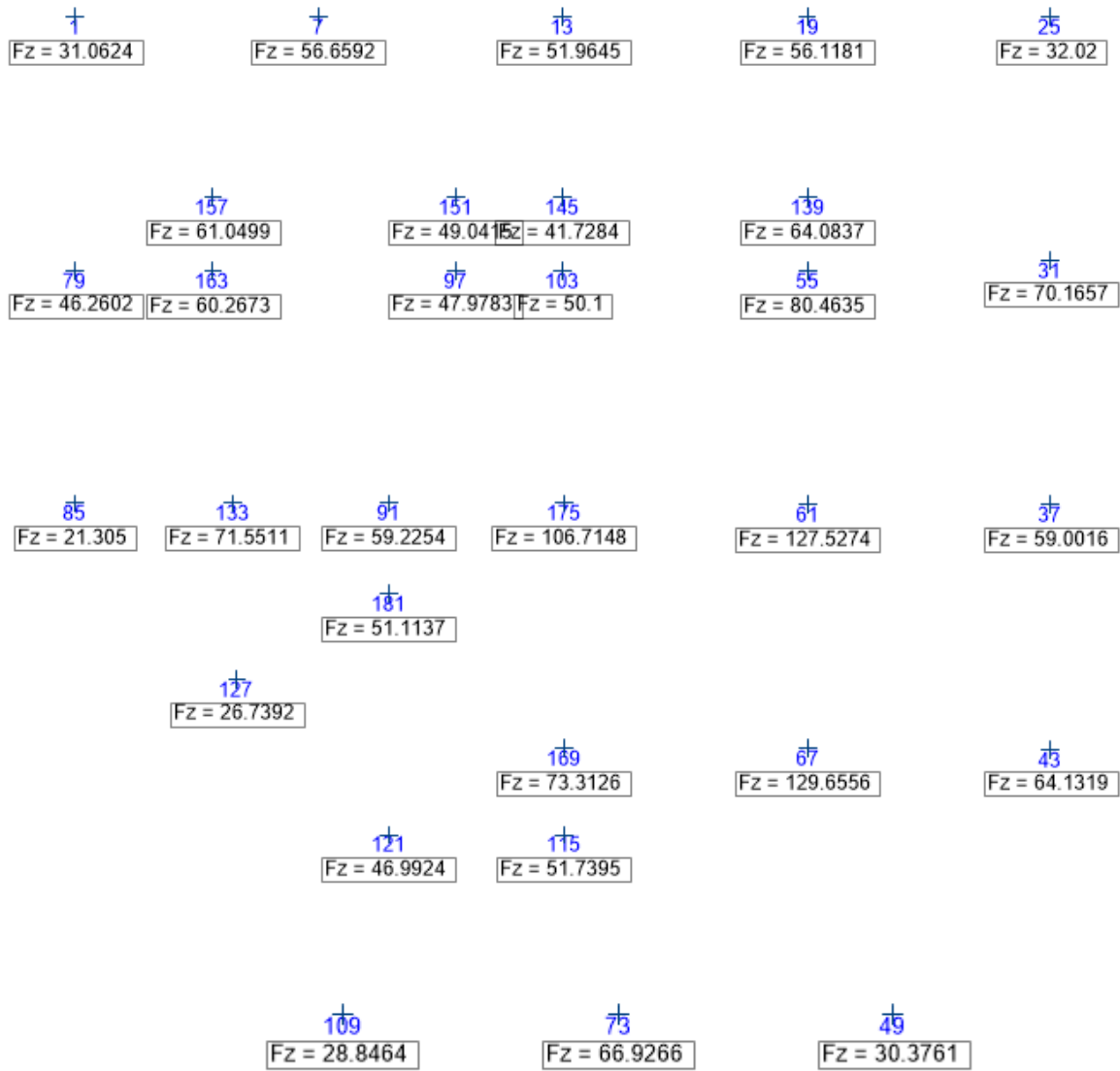

Figure 3.7 Column Reactions

Design equations for columns:

- Slenderness ratio = $\frac{k \cdot \text{effective height}}{t}$
- K=constant depends on the upper and lower condition of the column

<i>Upper End Conditions</i>	<i>Unbraced Columns</i>		
	<i>Lower End Conditions</i>		
	<i>Case (1)</i>	<i>Case (2)</i>	<i>Case (3)</i>
<i>Case (1)</i>	<i>1.20</i>	<i>1.30</i>	<i>1.60</i>
<i>Case (2)</i>	<i>1.30</i>	<i>1.50</i>	<i>1.80</i>
<i>Case (3)</i>	<i>1.60</i>	<i>1.80</i>	—
<i>Case (4)</i>	<i>2.20</i>	—	—

Figure 3.8 K values

Which caes 1 is a fixed joint, case 2, partially fixed and case 3 is a hinged joint

For unbraced columns if slenderness ratio is between 10 and 23 its considered to be a short column and if not it's a long column and there is an additional moment due to buckling.

- Additional moment = $p \cdot \delta$
- $\Delta = \frac{\text{slenderness ratio}^2 \cdot b}{2000}$
- $E = \frac{\text{moment}}{\text{axial load}}$, if $\frac{e}{t} \geq 0.5$ its big eccentricity if it is ≤ 0.5 its small eccentricity

-By applying those equations

Design of Long Column

Input Data:

Out of Plan (b)

Type of Column

Rectangular

Type of Moment

Zero moment

$P_u =$	120	t
$H_o =$	4	m
$b =$	0.4	m

0
0

In Plan (t)

Type of Moment

Zero moment

$H_o =$	4	m
$t =$	0.4	m

0
0

Unbraced $\delta :$
 Upper end: Partially Fixed
 Lower end: Fixed

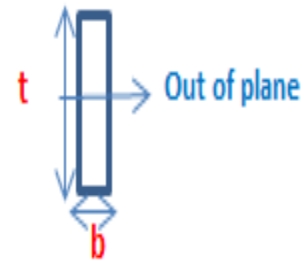

Unbraced $\delta :$
 Upper end: Partially Fixed
 Lower end: Fixed

Design:

Out of Plan

$K = 1.3$ $\lambda = 13$

Long Column

$M_{add} = 4.056$ m.t

$M_i = 0$ m.t

$M_y \text{ Design} = 4.056$ m.t

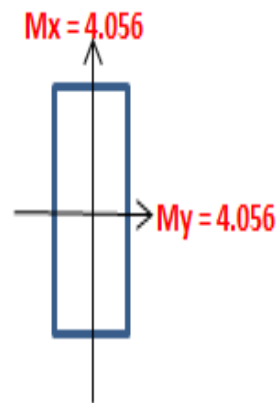

In Plan

$K = 1.3$ $\lambda = 13$

Long Column

$M_{add} = 4.056$ m.t

$M_i = 0$ m.t

$M_x \text{ Design} = 4.056$ m.t

Final Loads:

$N_u = 120$ t

$M_{u \text{ add}} = 4.056$ m.t

$M_{u \text{ ext}} = 4.056$ m.t

Bi-axial moment

$M_x = 4.056$ m.t

$a' = 0.375$ $M_x / a' = 10.816$ $M_x / a' \leq M_y / b'$

$M_y = 4.056$ m.t

$b' = 0.375$ $M_y / b' = 10.816$ $\beta = 0.8$

Mu=	7.31	m.t
Nu=	120	t
Qu=	0	t
Fcu=	300	Kg/cm2
Fy=	3600	Kg/cm2
Yc=	1.5	
Ys=	1.15	

Fixed Design
Compression force
 Rec. Sec.

t=	40	cm
b=	40	cm
Cover=	2.5	cm
∅ str.=	8	mm
n=	4	branch
Fy str.=	2400	Kg/cm2

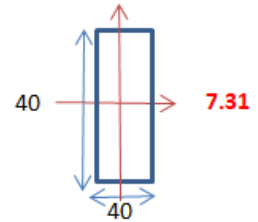

Design:

d=	37.5	cm
t=	40	cm
e=	0.06092	m
e/t=	0.15229	m

K*(e/t)=	0.039
K=	0.25 > 0.04
α=	1
ξ=	0.8

es =	0.23592	m
Mus =	28.31	m.t
C1=	2.45	
X1=	0.62	
J1=	0.66	

Use (I.D.),zone B or C Zone = **C**

As =	7.408	cm2
As' =	7.408	cm2

4 ∅	16	Losses 0.64 cm2
4 ∅	16	Losses 0.64 cm2

Design:

d=	37.5	cm
t=	40	cm
e=	0.06092	m
e/t=	0.15229	m

K*(e/t)=	0.039
K=	0.25 > 0.04
α=	1
ξ=	0.8

es =	0.23592	m
Mus =	28.31	m.t
C1=	2.45	
X1=	0.62	
J1=	0.66	

Use (I.D.),zone B or C Zone = **C**

As =	7.408	cm2
As' =	7.408	cm2

4 ∅	16	Losses 0.64 cm2
4 ∅	16	Losses 0.64 cm2

Check Of Shear:

qu=	0	Kg/cm2
qcu min=	10.61	Kg/cm2
qcu max=	31.12	Kg/cm2
qrqu.=	0	Kg/cm2

qcu min > qu < qcu max I'll Use **5** ∅ **8**
 qst= 5.25 Kg/cm2 Stirrups enough

Use min Stirrups

3.4 Structural plans

3.4.1 Slab reinforcement

- All axes and dimensions should be revised with architecture and mechanical drawings
- The strength of reinforced concrete used in design 250 kg/cm^2 after 28 days from pouring
- The strength of plain concrete used in design 180 kg/cm^2 after 28 days from pouring
- The reinforced concrete mix should be designed to achieve required strength and cement content should not be less than 350 kg/cm^2
- The plain concrete mix should be designed to achieve required strength and cement content should not be less than 250 kg/cm^2
- All steel splices should not be less than 60
- For diameters 8 mm mild steel is used (24/35) with yield strength not less than 2400 kg/cm^2
- For diameters larger than 8 mm high strength steel is used (36/52) with yield strength not less than 3600 kg/cm^2

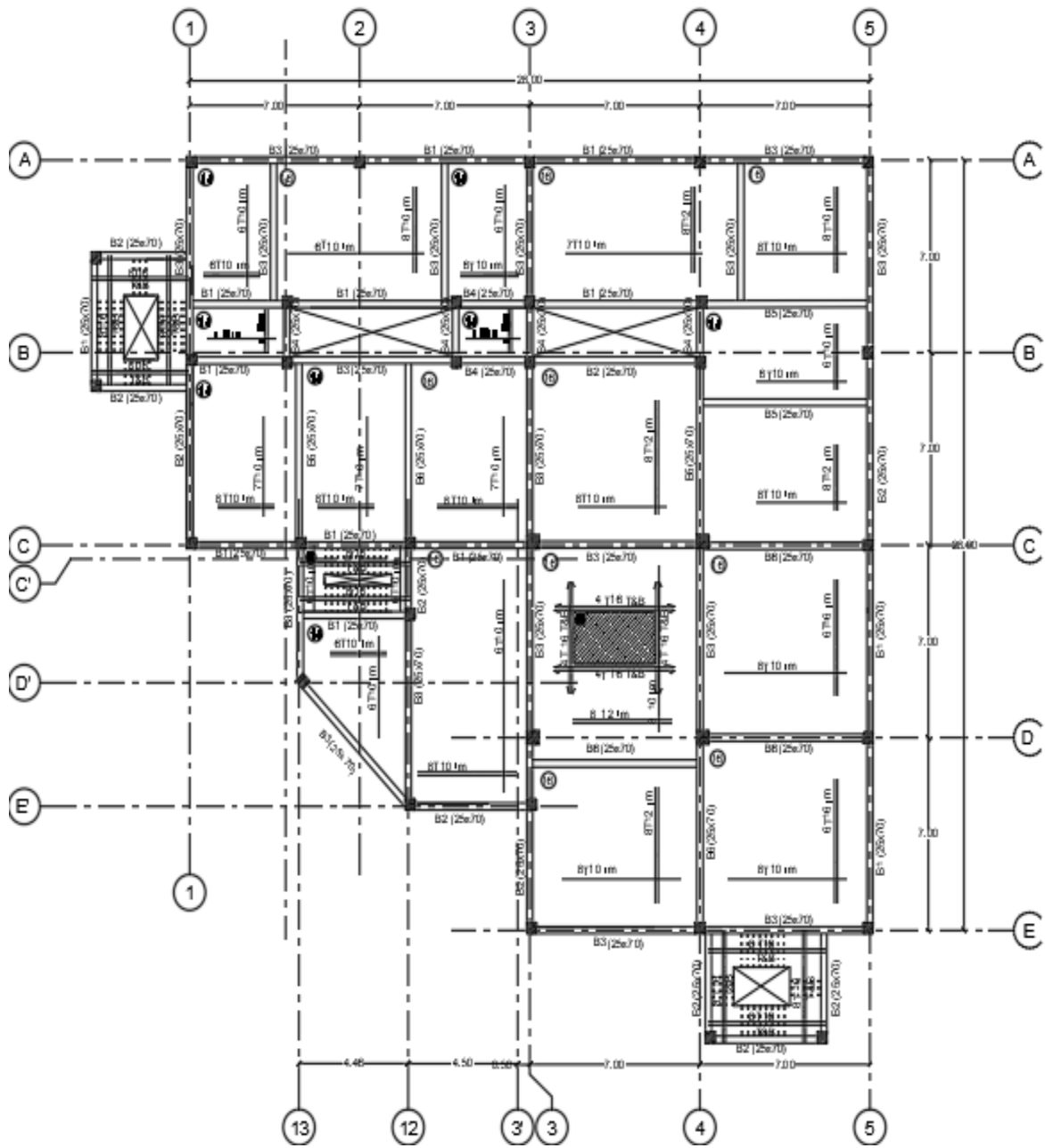
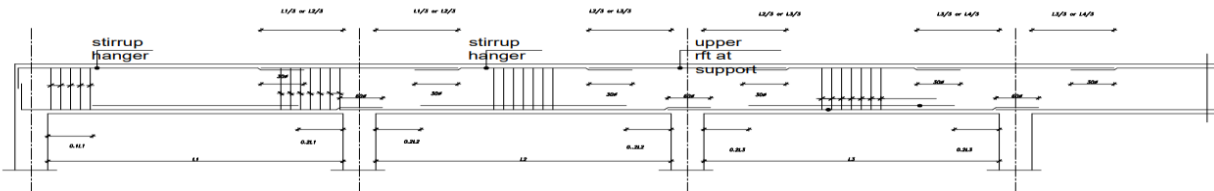

Figure 3.9 Ground Slab reinforcement

● **BEAMS TABLE**

Beam	LOWER	RFT	UPPER	RFT	stirrups
	Long	Short	middle	at support	
B1	3Ø16	—	3Ø12	4Ø16	5Ø8/m
B2	2Ø16	2Ø16	3Ø12	8Ø16	5Ø8/m
B3	3Ø16	3Ø16	3Ø12	10Ø16	6Ø10/m
B4	3Ø12	—	6Ø16	6Ø16	6Ø10/m
B5	4Ø16	4Ø16	3Ø12	10Ø16	6Ø10/m
B6	5Ø16	5Ø16	3Ø12	12Ø16	6Ø10/m

Figure 3.10 Beams table



Continuous beam

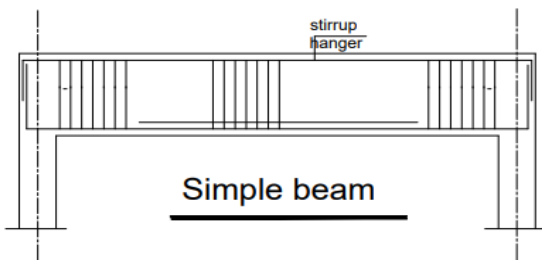

Simple beam

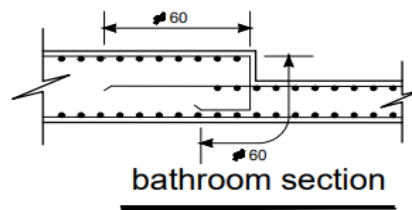

bathroom section

Figure 3.11 Details

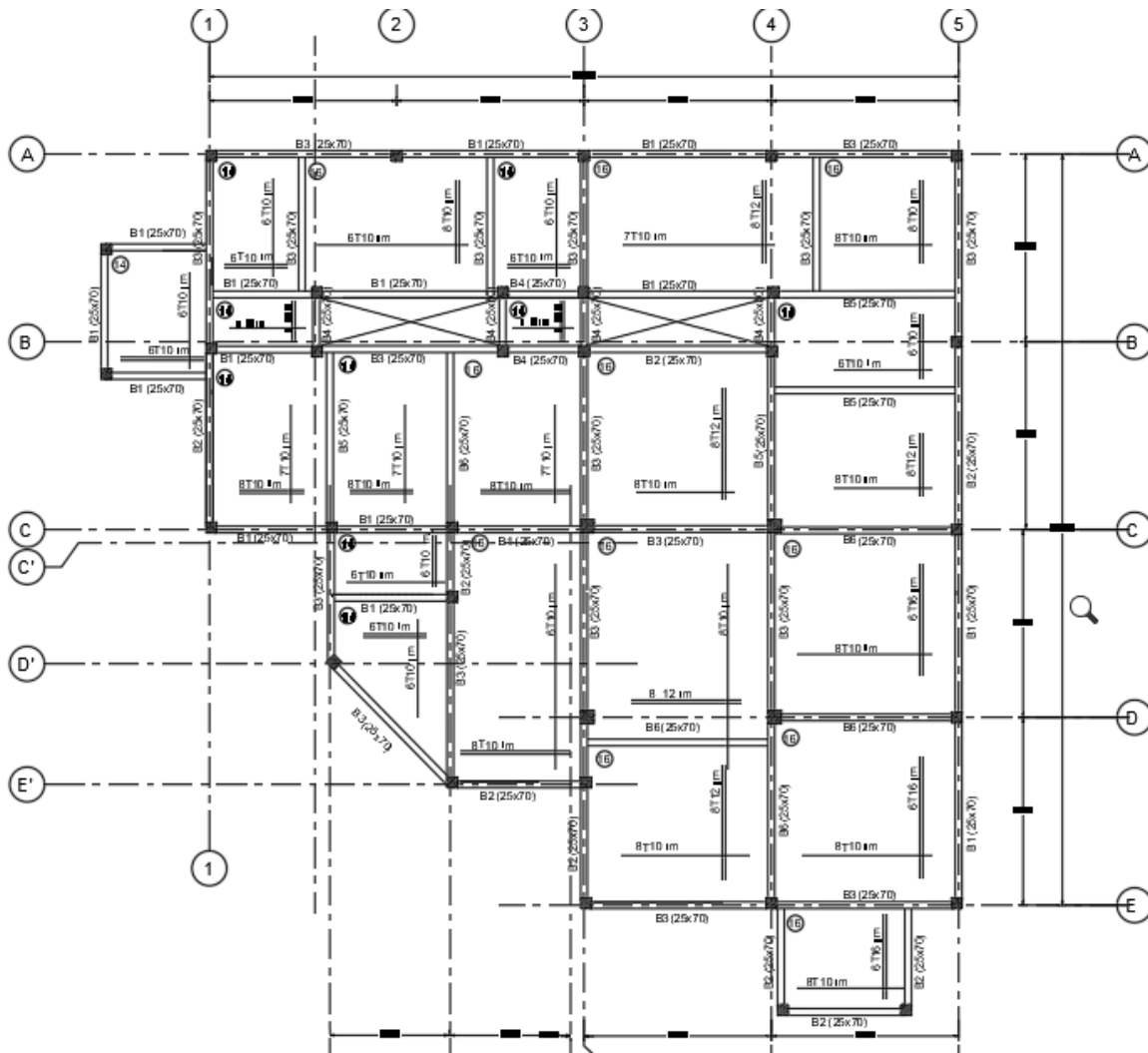

Figure 3.12 First slab reinforcement

3.4.2 Columns and axes:

- All axes and dimensions should be revised with architecture and mechanical drawings
- The strength of reinforced concrete used in design 300 kg/cm^2 after 28 days from pouring
- The strength of plain concrete used in design 180 kg/cm^2 after 28 days from pouring
- The reinforced concrete mix should be designed to achieve required strength and cement content should not be less than 350 kg/cm^2
- The plain concrete mix should be designed to achieve required strength and cement content should not be less than 250 kg/cm^2
- All steel splices should not be less than 60
- For diameters 8 mm mild steel is used (24/35) with yield strength not less than 2400 kg/cm^2
- For diameters larger than 8 mm high strength steel is used (6/52) with yield strength not less than 3600 kg/cm^2

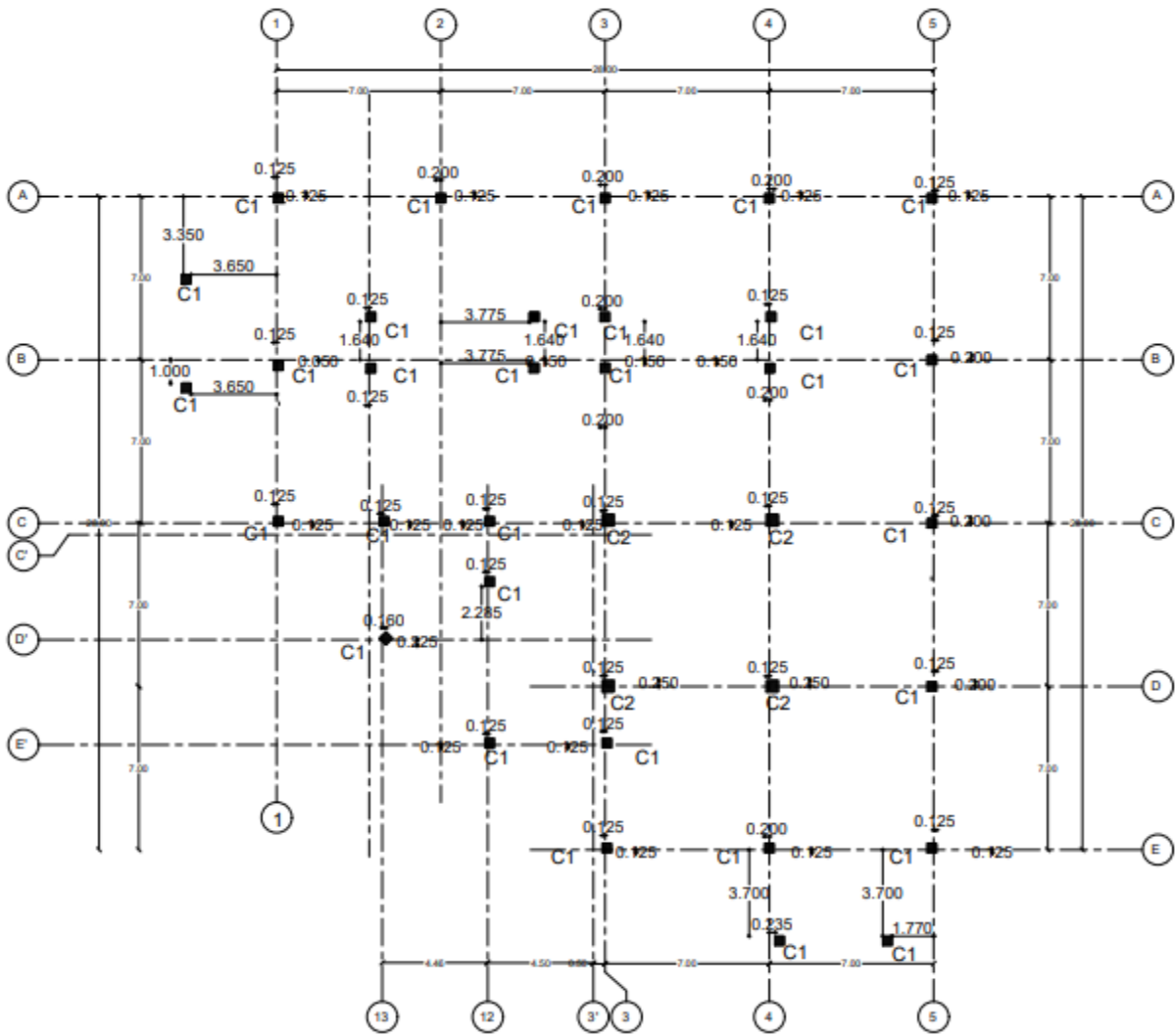

Figure 3.13 Columns and axes

3.4.2.1 COLUMNS TABLE

Column	Dimensions		RFT	Stirrups
C1	40	40	8 ϕ 16	6 ϕ 8/m
C2	50	50	10 ϕ 16	6 ϕ 8/m

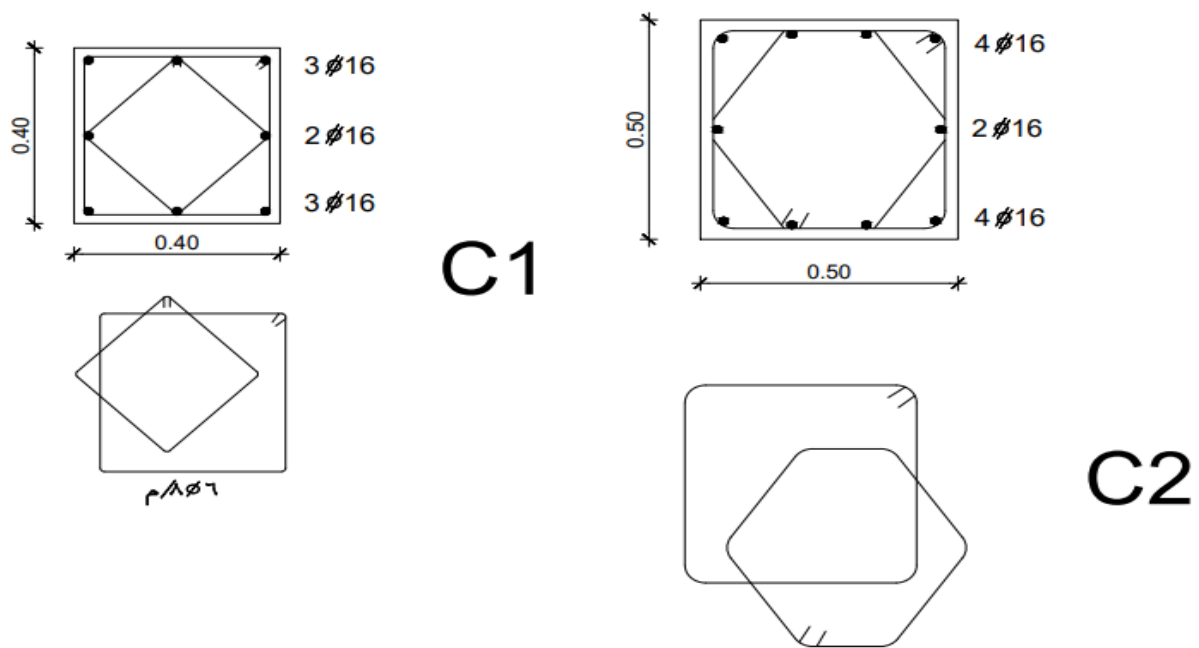

Figure 3.14 Columns details

3.4.3 Foundation:

- All axes and dimensions should be revised with architecture and mechanical drawings.
- The foundation is designed to bear 2 stories
- The foundation is isolated footing
- The concrete cover for footings is 7 cm
- The net bearing capacity is 1.5 kg/cm^2
- The strength of reinforced concrete used in design 250 kg/cm^2 after 28 days from pouring
- The strength of plain concrete used in design 180 kg/cm^2 after 28 days from pouring
- The reinforced concrete mix should be designed to achieve required strength and cement content should not be less than 350 kg/cm^2
- The plain concrete mix should be designed to achieve required strength and cement content should not be less than 250 kg/cm^2
- All steel splices should not be less than 60
- For diameters 8 mm mild steel is used (24/35) with yield strength not less than 2400 kg/cm^2
- For diameters larger than 8 mm high strength steel is used (36/52) with yield strength not less than 3600 kg/cm^2

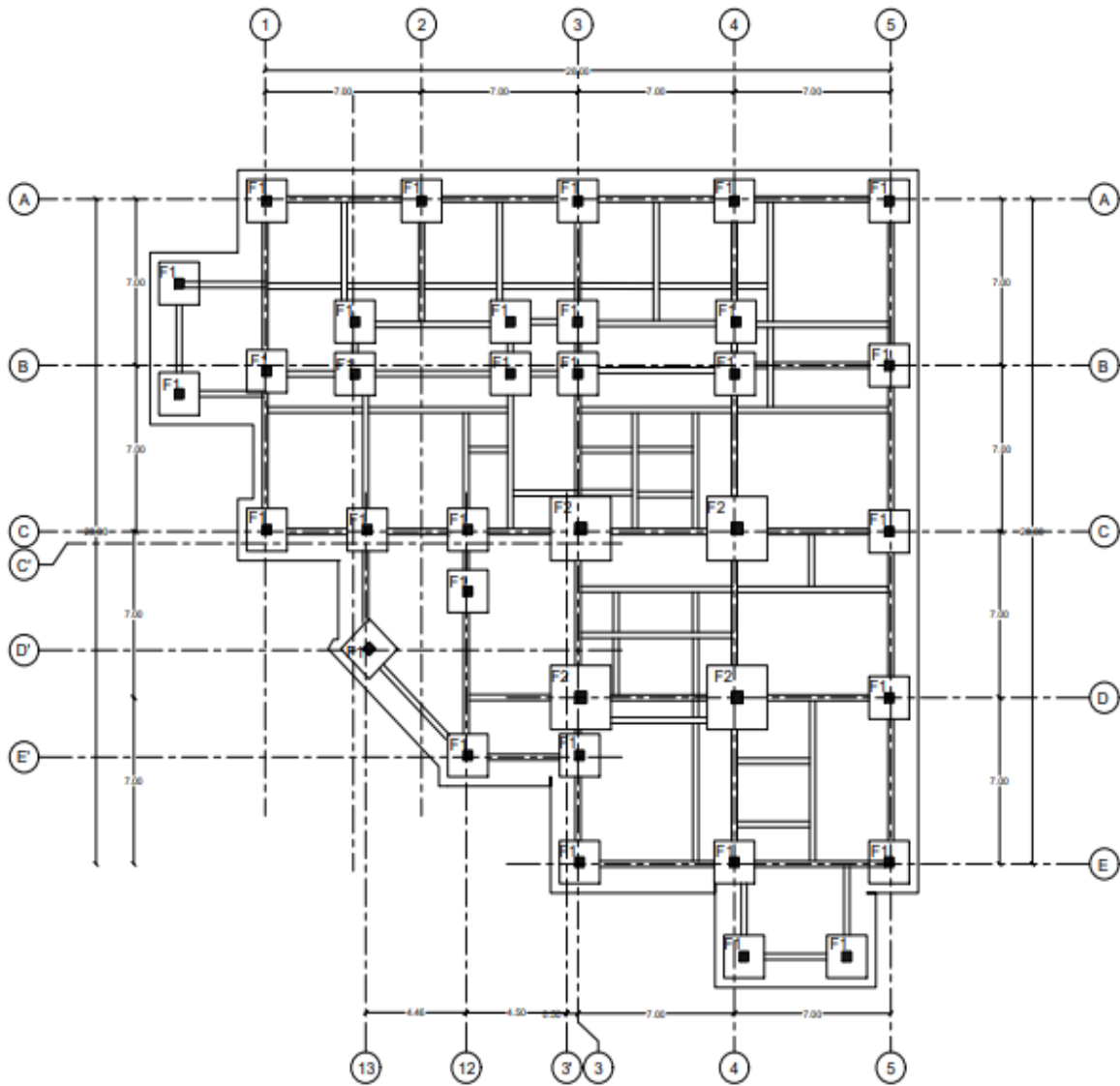
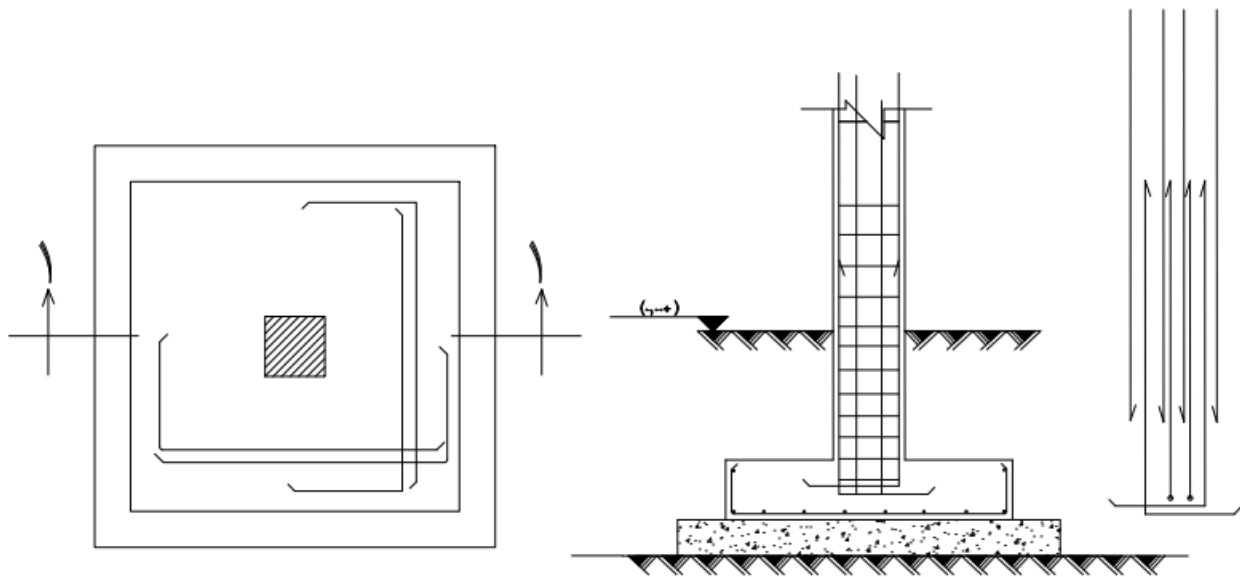

Figure 3.15 Foundations

3.4.3.1 FOOTING TABLE:

FOOTING	DIMENSIONS		RFT	Longitudinal
	PLAIN CONCRETE	REINFORCED CONCRETE	Transverse	
F1	Raft with thickness 40 cm and with offset 40 cm from rc	1.8X1.8X0.6	6Ø16/M	6Ø16/M
F2		2.7X2.7X0.6	6Ø16/M	6Ø16/M



Reinforcement details for footing

Figure 3.16 Foundation details

CHAPTER 4. TECHNOLOGY OF CONSTRUCTION

Reinforced concrete solid slabs are a slab resting on beams, beams resting on columns it is manufactured directly on the construction site. The concrete used is C25 concrete and rolled reinforcement, bonded as a mesh. A solid slab requires the use of a formwork, which is left for 28 days until the concrete has fully cured and has attained the required concrete strength. The thickness of the slab is usually 80-200 mm.

Step by step construction of system as following:

- Construction of plan concrete for foundation
- Construction of RC foundation
- Construction of RC columns
- Construction of stairs
- Construction of Beams
- Construction of solid slabs

The pouring of solid slab is done with a concrete pouring pump, we have chosen this technique because of its advantages, using of concrete pumps in large-scale commercial construction project is a common sight. But, that doesn't mean, these are for large sized projects. Medium to small sized construction projects, be it commercial or residential can also use it effectively. Concrete pumping is the most accurate way of pouring concrete achieving quality results. There are two main types of concrete pumps:

4.1 Types of pumps

4.1.1 Boom pumps.

This type of pump is attached to a truck and uses a remote controlled articulating robotic arm, also known as boom, to place the concrete accurately at the construction site. It is also known as a truck mounted boom pump. Boom pumps are generally used in large construction projects because of its capability of pumping high volume of concrete in less time. It also saves substantial labor because of its multi-purpose robotic arm.



Figure 4.1 Boom pump

4.1.2 Line pumps.

This type of pump is mounted on a trailer and requires steel or rubber hoses to be attached to the outlet of the machine. The hoses are generally manually attached and can also be joined to another extension hoses to reach the appropriate site where the concrete needs to be put. Trailer pumps pump concrete at a rate lower than that of boom pumps and therefore are used in

applications that require smaller volume pumping such as swimming pools, sidewalks, and small homes concrete slabs.



Figure 4.2 Line pump

Both have specific application and the right one is to be picked depending on the situation.

In our situation it is preferred to use a line pump as it's a small scale project.

Advantages of using Concrete Pumps:

- **Faster Pouring speed:**
Pouring concrete with concrete pumps is the fastest and the simplest. Pumping equipment's are mounted on a truck or a trailer to make them accessible to all areas of the site easily.
- **Reduced number of labor:**
There is a scarcity of labor in construction industry. Finding a skilled labor for construction jobs is a challenge. Thus, it makes perfect sense to hire

concrete pumps. The whole process of laying concrete is executed by several operators and laborers are not needed to carry concrete batches manually.

- Higher Accuracy and Quality in Concrete Pouring:

Regardless of the concrete pump you choose, the pouring of concrete is of higher accuracy and quality. It results in minimal material wastage. Whether you want to pour concrete on top of a high rise building or in a foundation slab, concrete pumps can deliver concrete mix to almost any area without leaving spills and lumps on the way.

- Pumps can easily access any non-conventional area of the construction site unlike barrows which takes ages to reach.
- The reinforcement way of solid slab is considered as main steel and secondary steel, the main steel is in the direction of the load (lower mesh) unless in case of thickness more than 16 cm we add (upper mesh) to resist shrinkage.
- The secondary steel is in a perpendicular direction of the main steel its important for resisting deflection, shrinkage and loads in long direction

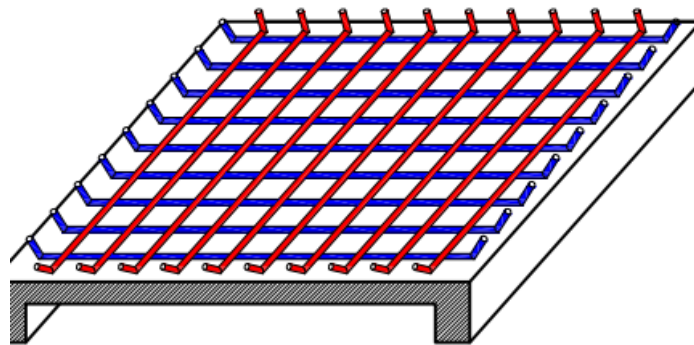

Figure 4.3 Slab reinforcement

CONCLUSIONS

The topic of the thesis is office building in the town of Okhtyrka City of Sumy region . For my bachelor thesis I chose a 2-storey office building with ground and first floor. The office Centre will accommodate around 50 workers in two floors, the site covers approximately (665 m²) in total.

The two stories Ground floor and First floor consists of reinforced concrete framed structure solid slab system. As it is the suitable system for small areas also it's the best system to resist lateral loads due to the framing action.

The natural conditions for construction of the building were estimated, Bearing elements were designed with the help of program SAFE.

Floor cover, walls loads were taken into consideration The external design of the building is worthy of attention, The facade is made with large portions of glass which gives elegant view for a working place.

The safety of the workers was achieved through two escape stairs in the case of emergency.

There are atriums with green areas in the two floors for convenience of workers,

The concrete slabs were constructed using concrete pumps which is preferred according to its advantages.

References

1. Klimenko FE Metal structures: textbook. near. / FE Klimenko, VM Barabash, LI Storozhenko. - Lviv: Svit, 2002. - 311 p.
2. Metal structures: textbook. / VO Permyakov, OO Nilov, OV Szymanowski and others; for the head ed. VO Permyakova and OV Szymanowski. - К .: Сталь, 2008. - 812 с.
3. Bilyk SI, Shimanovsky OV, Nilov OO, Lavrinenko LI, Vladimirsky VO Metal structures: Volume 2. Structures metal frames of industrial buildings: A textbook for higher education of educational institutions / Editorial Board: O.B. Szymanowski, S.I. Bilyk, OO Nilov. - Kamyanets-Podilsky: Ruta Printing House LLC, 2021. - 448 pp., Fig. 207, table. 109.
4. Textbook. METAL STRUCTURES second edition OO Nilov, VO Пермяков, O.B. Szymanowski, S.I. Bilyk, L.I. Lavrinenko, ID Belov, V.O. Volodymyrskyi, Kyiv, Stal Publishing House & quot; 2010
5. Methodical instructions. Metal structures, design of workers drawings by VO Permyakov, ID Belov, OB Glitin, Kyiv, publishing house KNUBA 2002.
6. Architectural structures of industrial buildings: textbook. way. RI Kinash, DG Gladishev; Ministry of Education and Science of Ukraine, Nat. University & quot; Lviv. Polytechnic & quot; ;. - Lviv: Lviv Publishing House. Polytechnic University, 2015. - 288 p.
7. Getun GV Architecture of buildings and structures. Fundamentals of design Book, 2nd edition, revised and supplemented. - Kyiv: Condor, 2012. -380 s.

8. Vasilchenko VT Handbook of metal constructors / В.Т. Васильченко, А.Н. Rutman, Е.Р. Lukyanenko. - К .: Builder, 1980. - 288 p.
9. Likhtarnikov Ya.M. Calculation of steel structures: a reference manual / J.M. Likhtarnikov, VM Klykov, DV Ladyzhensky - К .: Builder, 1984. - 368 p.
10. Shereshevsky IA Design of industrial buildings and structures. - М .: "Architecture-C", 2005. - 186 p.
11. Gorodetsky DA Software complex Lira-Sapr 2013 / D.A. Городецкий, М.С. Barabash, RJ Vodopyanov, VP Titok, AE Artamonova // Tutorial. - Kyiv: 2013. - electronic edition. - 376 p.
12. Pershakov VM Building constructions / V.M. Першаков, В.С. Gorbatov, М.С. Barabash // Textbook. - К .: НАУ, 2005. - 109 с.